



# **Power Backup Cabinet**

## **INSTRUCTION AND TECHNICAL REFERENCE MANUAL**

**650 W UPS POWER BACKUP**

**1300 W UPS POWER BACKUP**

**400 W UPS POWER BACKUP  
With a Sealed Cabinet**

## **SAFETY**

**This manual contains important instructions for the PBC models. Follow instructions during Installation and maintenance of the UPS, Electronic Tray and Battery Tray.**

**When using electrical equipment, basic safety precautions should all always be followed including the following:**

### **READ and FOLLOW ALL SAFETY INSTRUCTIONS**

- **Do not mount near gas or electric heaters.**
- **Check by inspection that all electrical connections are clean and tight.**
- **Equipment should be mounted in a location where it will not readily be subject to tampering by unauthorized personal.**
- **Equipment should be kept under lock and key.**
- **Only qualified electrical personal should be permitted to maintain or service equipment.**
- **Only accessories or equipment recommend by manufacturer shall be used with this equipment, contact factory for approval.**
- **Check by inspection that all electrical connections are clean and tight.**
- **All terminal connections shall be TORQUE to value in table below.**

<b>Terminal</b>	<b>Torque</b>	
	<b>In / lbs.</b>	<b>N-meter</b>
<b>TB 1</b>	<b>18.0</b>	<b>2.03</b>
<b>TB 2</b>	<b>18.0</b>	<b>2.03</b>
<b>TB 3</b>	<b>5.0</b>	<b>.56</b>
<b>XFMR LEADS</b>	<b>30.0</b>	<b>.56</b>
<b>CB 2 TRMINALS</b>	<b>30.0</b>	<b>.56</b>
<b>CABINET GND</b>	<b>30.0</b>	<b>.56</b>
<b>DOOR GND</b>	<b>30.0</b>	<b>.56</b>
<b>GROUND LUG</b>	<b>50.0</b>	<b>5.65</b>
<b>LIFTING PLATES</b>	<b>94.0</b>	<b>10.62</b>
<b>PAD MOUNTING BRACKET</b>	<b>94.0</b>	<b>10.62</b>
<b>TRAY TO CABINET BOLTS</b>	<b>76.0</b>	<b>8.58</b>

# WORK SAFETY INSTRUCTIONS

**Definition: The Caution and Warning markings and labels.**



Indicates the surface temperature may be HOT! (label is red).



Caution

Indicates Caution (label is yellow).

1. Located by Input CB1 indicates turning these breakers to ON energizes unit. As the unit maybe energized even after input CB1 is turned to OFF by the power supplied by the batteries, turn the battery tray CB2 breakers to OFF.
2. Located by Output CB3 indicates that turning this breaker to OFF, shuts OFF all output power that is connected at TB2.
3. Located by battery tray CB2 indicates that turning ON this breaker supplies an alternate battery power source to electronic tray and the output even when the input CB1 is OFF. Turn breaker CB2 to OFF prevents the batteries from supplying power to the output when in-out fails or drips (goes low in voltage).
4. Located by the door locks indicates the requirement of a special tool, #8 allen key.
  - a. Only qualified personnel shall use the Allen Key in the ¼ turn lock to open the door and access the inside of unit.
5. Located by the RED labels on the front panel of battery tray warns that Electric Shock Hazard may be present with the input power disconnected. Ups may be energized from the batteries.
6. Located by the YELLOW labels on the left front side panel of battery tray warns battery terminals are coated with PRO-OX to seal and protect.
  - a. PRO-OX contains petroleum distillates.
  - b. WASH! hands thoroughly after touching with soap and water.
  - c. If ingested induce vomiting.



**RED LABEL is for WARNING!**

1. Located by the RED labels on the front panel of battery tray warns Electric Shock Hazard may be present, DO NOT TOUCH uninsulated battery terminals as from 12 volts DC to 72 volts DC, present at all times.
2. Located by the RED labels on the front panel of battery tray warns to use the same type and rating of FUSE to reduce the risk of fire.

3. Located by the TB1 and TB3 on the front panel of electric tray and inside of tray by TB4 warns electric shock hazard may be present from live voltages and DO NOT TOUCH the terminals of connector.
4. Located by the TB1 and TB3 on the front panel of electronic tray. See installation manual before making connections.
5. By the RED labels on the front panel of battery tray warns to use COPPER conductors only for customer's connections.

Follow all safety precautions:

<b>CAUTION! ALL POWER TO THE UNIT SHALL BE LOCKED AND TAGED “ OFF ” BEFORE ANY SERVICING OR OTHER WORK ON THE UNIT.</b>
<b>CAUTION! THE BATTERY POWER TO THE UNIT SHALL BE LOCKED AND TAGED “ OFF ” BEFORE ANY SERVICING OR OTHER WORK ON THE UNIT.</b>
<b>CAUTION! THE BATTERY VOLTAGE CAN CAUSE THE UNIT TO OPERATE WITH AC LINE POWER “ OFF ” CARE SHOULD BE USED AT ALL TIMES.</b>
<b>CAUTION! A BATTERY CAN PRESENT A RISK OF ELECTRICAL SHOCK AND HAVE A VERY HIGH SHORT CIRCUIT CURRENT.</b>
<b>CAUTION! ALL BATTERY WORK SHOULD BE PERFORMED ON THE GROUND, AS THE BATTERY TRAY WITH BATTERIES CAN WEIGHT OVER 290 LBS. HANDLE CAREFULLY.</b>

## **WEIGHT OF COMPONENTS**

### **650 WATT MODEL**

- The 650 W Unit weight is approximately 365 lbs.
- The 650 W Electronic Tray weight is approximately 90 lbs.
- The 650 W Battery Tray weight, set of 4 batteries, is approximately 200 lbs.

### **1300 WATT MODEL**

- The 1300 W Unit weight is approximately 455 lbs.
- The 1300 W Electronic Tray weight is approximately 95 lbs.
- The 1300 W Battery Tray, set of 6 batteries, weight is approximately 200 lbs.

## CAUTION !

**Units are very heavy, use proper equipment to lift & move.  
HANDLE CAREFULLY.**

### BOTH MODELS

- The Pole / Wall mount adapter plate (2 required) weight is approximately 26 lbs.
- The Pole / Wall mount adapter hardware kit weight is approximately 1 lb.
- The Pad / Roof plates (2 required) weight are approximately 12 lbs. each.
- The Pad / Roof hardware kit weight is approximately 8 oz.
- The Empty Cabinet weight is approximately 85 lbs.

## WARNING !

- Battery shelf life, when stored under temperature conditions of 66°F ~ 90°F is five(5) months maximum after the ship date.
- Battery must be recharged after this date otherwise they will be damaged.
- The ship date is part of the serial number (see example below).

S/N 00 L7 02 00 #####  
Year                      Month                      Unit I.D. Number

- Over current protection for the output AC circuits is to be provided by the contractor during the installation of system.
- Only on special order is multi- output AC over current protection supplied.

## TABLE OF CONTENTS

<b>SECTION 1 – UNIT OPERATION AND FEATURES:</b> .....	<b>1</b>
1 - 1 Overview .....	1
1 - 2 Features .....	1
1 - 3 Ruggedization Features .....	3
1 - 4 Safety and EMI Regulatory Aspects .....	4
1 - 5 Domestic/International .....	4
1 - 6 Mounting Features .....	4
1 - 7 Other Important Design Features .....	4
1 - 8 Electrical – Input/Outputs .....	8
1 - 9 Electrical – Outputs Characteristic .....	8
1 - 10 Mechanical Overall Dimensions and Weight .....	8
1 - 11 Theory of Operation.....	9
<b>SECTION 2 – PREINSTALLATION:</b> .....	<b>13</b>
2 - 1 Location Considerations .....	13
2 - 2 Positioning.....	13
2 - 3 Mechanical Overall Dimensions & Weight .....	13
2 - 4 Site Planning Specifications .....	13
2 - 5 Site Detail Electrical Specifications.....	13
2 - 6 Mechanical Overall Outline Dimensions .....	14
2 - 7 Pad Mounting Layout.....	14
<b>SECTION 3 - PCB INSTALLATION:</b> .....	<b>15</b>
3 - 1 PBC Unpacking .....	15
3 - 2 Inspection .....	15
3 - 3 PBC Storage .....	15
3 - 4 PBC Installation .....	16
3 - 5 Lifting Requirements .....	16
3 - 6 PBC Pole Installation .....	17
3 - 7 PBC to Pole Grounding .....	18
3 - 8 PBC Grounding Test .....	19
3 - 9 PBC Conduit Installation: .....	20
3 - 10 Electronic Tray Wiring: .....	20
3 - 11 Electronic Tray Input & Output Wiring .....	21
3 - 12 Electronic Tray Output Wiring to Heaters .....	24
3 - 13 Electronic Tray Wiring Checkout .....	25
3 - 14 PBC Battery Tray Connection .....	25
3 - 15 PBC Ready for Normal Operation Check: .....	25
3 - 16 PBC Ready for Check Battery Backup Operation .....	26
3 - 17 PBC is Ready for Usage .....	26
3 - 18 PBC Pad Layout .....	26
3 - 19 PBC Pad Installation .....	26

## TABLE OF CONTENTS (cont.)

<b>SECTION 4 – SERVICING OF A UNIT .....</b>	<b>27</b>
<b>4 – 1 Modularity of Internal Components.....</b>	<b>27</b>
<b>4 – 2 Servicing Safety .....</b>	<b>27</b>
<b>4 – 3 Electronic Tray Removal .....</b>	<b>28</b>
<b>4 – 4 Replacing Electronic Tray .....</b>	<b>28</b>
<b>4 – 5 Battery Tray Removal &amp; Servicing.....</b>	<b>28</b>
<b>4 – 6 Replacement of Battery Tray.....</b>	<b>28</b>
<b>4 – 7 Replacing a Battery.....</b>	<b>29</b>
<b>4 – 8 Removing the Battery from Battery Tray .....</b>	<b>29</b>
<b>4 – 9 Removing Filter Screen .....</b>	<b>29</b>
<b>Appendix A: Summary of Indicators and Controls: .....</b>	<b>30</b>
<b>Appendix B: Installation Accessory Kit - Parts List : .....</b>	<b>31</b>
<b>Appendix C: Battery Maintenance Testing &amp; Specifications: .....</b>	<b>33</b>
<b>Appendix D: Troubleshooting &amp; Diagnostics: .....</b>	<b>35</b>

# SECTION 1 - UNIT OPERATION AND FEATURES

## 1-1 Overview

Within each Power Backup Cabinet is an Uninterruptible Power Supply (UPS). The purpose of this device is to provide power to the critical load during brown out, or black out conditions, without disruption of operation of the load equipment. When the unit operates in the backup mode, the AC power for the load comes from a set of internal batteries and Inverter. The battery charger keeps the batteries charged and ready to fulfill the unit's function to supply reserve power.

Also, these cabinets provide an additional level of power protection from transients, surges, electrical noise, and other power disturbances.

What differentiates this PBC from, off-the-shelf, UPS equipment is the high level to which these units have been "hardened" (ruggedized) to ensure continuous operation in very harsh environments, particularly outdoors.

## 1-2 Features

### Status Indicators

The unit has two major component trays. The Electronic Tray contains the battery charger, Inverter circuitry, input and output transformers, as well as the input/output terminals. The lower tray is the battery compartment. The Electronic Tray set of indicator lamps on the front panel display the unit's operational mode. (See Illustration 1-1 below) These lamps provide a positive visual indication of specific aspects of the units functional operation. These are as follows:

- **AC** AC On
- **INV** Inverter On
- **SUM** Summary Alarm Warning
- **LB** Low Battery Warning
- **HB and FB** Battery Voltage Level indicators.  
HB shows half charge % voltage and FB Full charge % voltage.
- **LL HL FL** Load Level Usage.  
LL= Low level load  
HL Half level load  
FL Full level load,
- **OL** Over Load of Unit

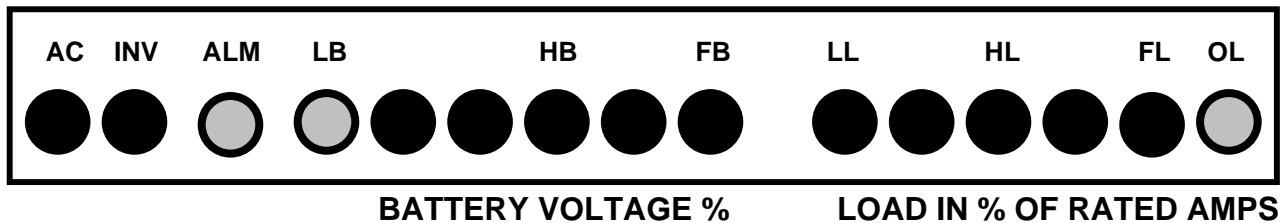

Electronic Tray - Status Panel  
Illustration 1-1



- **Alarm Signals**

Also providing information on the unit's status/particular aspects to the outside world by way of electrical signals is a DB-9 connector. This DB-9 connector is on the front console of the Electronic Tray. The interface provides a set of open and closed contacts, which relate the status of PBC to the outside world. An interface DB-9 connector and cable permit the unit to bring out the following signals with their normal state (open or closed). If the contact is not energized and the contact is closed, it is named "Normally Closed". If the contact is not energized and the contact is open, it is named "Normally Open".

- **Inverter LED is " On " the relay contacts are Normally Open (NO).**
- **Loss of Input Power, AC LED is " Off " the relay contacts are Normally Closed (NC).**
- **Low Battery LED is " On " the relay contacts are Normally Open (NO).**
- **Intrusion Switch, when the door is open the switch contacts are Normally Closed (NC).**

For the detailed pin out for the DB-9 connector see Illustration 1-2 below.

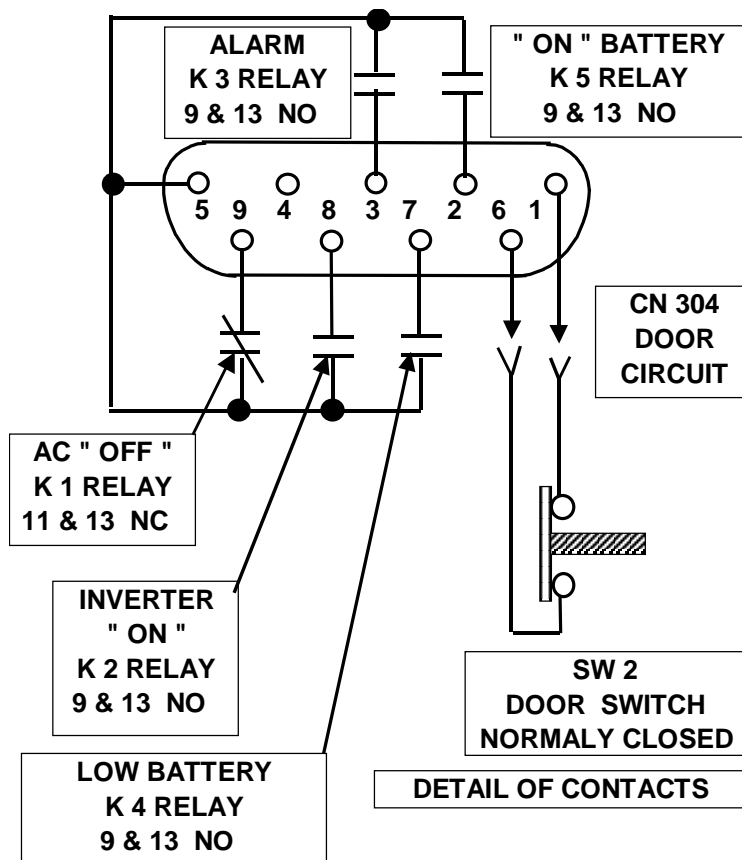

**Relays are dry contacts rated 2 AMPS @ 250 VAC**

**Illustration 1-2: DB-9 Connector**

- **Alarm cable**

The PBC units come with an Alarm Cable, 20 feet long, which connects to the DB-9 jack so the signals are available for external monitoring/status reporting equipment. The wiring of the cable matches the pin out detail as shown in Illustration 1-2 for the DB-9 jack.

- **DB-9 Connector Color Code:**

- **The normal contact condition is generally shown with power OFF.**

PIN OUT	WIRE COLOR	FUNCTION	NORMAL CONTACT
1	Black of Black / Blue	Door Switch, Intrusion Alarm	Normally Open
2	Black of Black / Red	ON BATTERY	FLASHING Normally Open
3	Black of Black / White	Summary Alarm Warning	Normally Open
4		Open no wire	N/A
5	Black of Black / Green	Return Common	Ground
6	Blue of Black / Blue	Door Switch	Normally Open
7	Red of Black / Red	Low Battery	Normally Open
8	White of Black / White	UPS " ON " , Inverter " ON "	Normally Open
9	Green of Black / Green	Input Failed	Normally Closed

- **Intrusion Switch**

An intrusion alarm switch resides within the cabinet to relay that unwanted entrance into the cabinet as been made. The plunger of the switch is in by the door when it's closed. In this condition, the switch presents an open circuit and the alarm is in the "off" state. When the door is open, the switch presents a closed circuit and the alarm is in the "on" state. One additional state is available on the switch. A technician working on the unit can pull the plunger out to a "neutral" position. The switch will be in the open state ( "off" ) and thus no alarm condition by-passed while he or she is working on the unit. See Illustration 1-3 for its location.

- **ESD Receptacle and Wrist Strap**

The ESD wrist strap plugs into the red connector receptacle on the front panel of the Electronic Tray. An ESD wrist strap is in the bottom of the cabinet. Any personnel working on the unit should be wearing the strap. The strap plugs into the RED banana plug receptacle to minimize the risk of damage to the ESD sensitive circuitry that of the electronics assembly.

### 1-3 Ruggedization Features

All PBC's designed to operate in most outdoors harsh environments. The unit has been subjected to outside independent labs to demonstrate that they are capable of withstanding severe outdoors operating conditions. Below is a listing of many of those conditions:

- **Wide Temperature Range**

The PBC designed and tested to operate in the outdoors over a wide range of temperatures, from -40 °C to + 52 °C plus a solar load of 70 watts / Ft<sup>2</sup>. The 1300 W unit has option of having internal heaters for the batteries to allow it to operate over a range of -40 °C to + 52 °C.

- **Shock and Vibration**

These devices are designed and tested to meet Bellcore specs for shock and vibration namely GR-63-CORE Issue 1 section 4.3 and GR-63-Core Issue 1 section 4.4 and earthquake zone 4.

- **High Input Voltage Surge Withstand Capability**

The unit internally has AC Surge protector ( ACT's TVSS) to ensure that lightning or other types of high voltage surges do not damage them. They meet IEEE 62.41 1991 (UL1449) level C3 input voltage surge, of 20,000 Volts @ 10,000 Amps.

- **Corrosion Resistant Cabinet**

The sheet -metal parts paint have been chosen by design and verified by testing to be rustproof.

- **Rain-Proofed Cabinet**

The cabinets designed and tested to meet UL50 (Type 3R) requirements and thereby to ensure that rain will not reach the critical electronics.

- **Easy Front Door Access**

This makes for effective field service access.

- **Filter for Dust, Dirt and Bug Resistant**

The cabinet has protection through filters to prevent adverse effects do to dust and dirt, as well as the intrusion of creatures such as bugs and rodents.

## **1-4 Safety and EMI Regulatory Aspects**

- **Safety**

The units designed and tested to meet UL 1778 and CSA 107.2 requirements.

- **EMC (Domestic)**

The PBC's design meets the requirements of FCC, 47 CFR, Part 15, Subpart B.

- **EMI (International)**

The PBC's conformity to EN55022 (CISPR22) FOR EMI compliance.

## **1-5 Domestic/International**

- **Input Frequency Selection**

The PBC's design will operate at 50 or 60 Hz. The frequency selection can be made by changing the jumper on terminal block TB 3. See the location of TB 3 on the Electronic Tray, in Illustration 1-3 and Details of connections in Illustration 3-5.

## **1-6 Mounting Features**

- **Pad or Floor Mounting**

PBC shall mount on a concrete pad, outdoor/indoor. The pad rail mounting comes with the hardware required. The rails can be in-line with door or crossways to door.

- **Pole or Wall Mounting**

PBC can be Pole or Wall mounts. The mounting brackets are an option and need to be order. Select options at time of purchase of individual units. The part numbers for these options are part of Appendix C of this manual.

## **1-7 Other Important Design Features**

- **Modularity of Internal Components**

The cabinet contains two physical assemblies;

- The Electronic Tray, with the UPS System.
- The Battery Tray contains the reserve stand-by batteries.

## 1-7 Other Important Design Features (continued)

- **Electronic Tray**

The inverter circuitry, front panel with connectors terminals and status panel, input and output isolation transformers ( as well as power for heaters in 1300 W ) and cooling fans are all located on this mechanical structure. (See Illustration 1- 3) Directly below for the front panel Illustration for an overview showing the components layout. Details of the connectors are shown in section 3 for electrical wiring of unit.

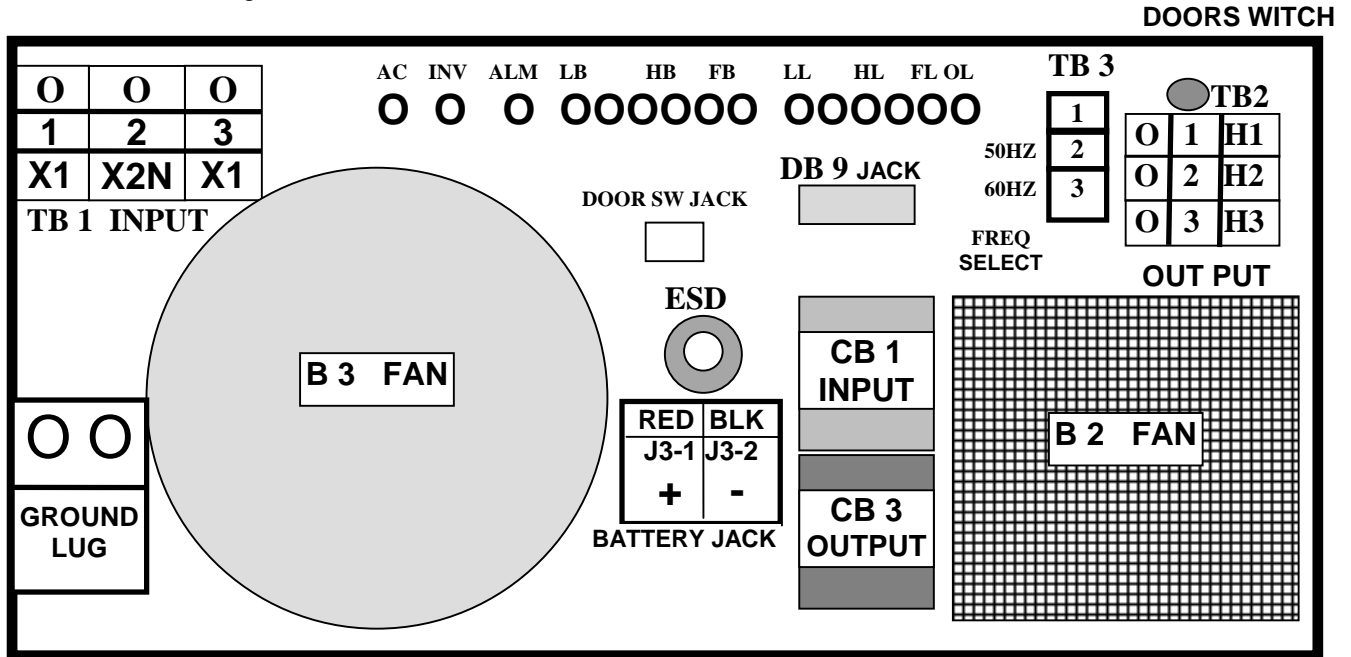

Electronics Tray ( Upper Tray )  
Illustration 1-3

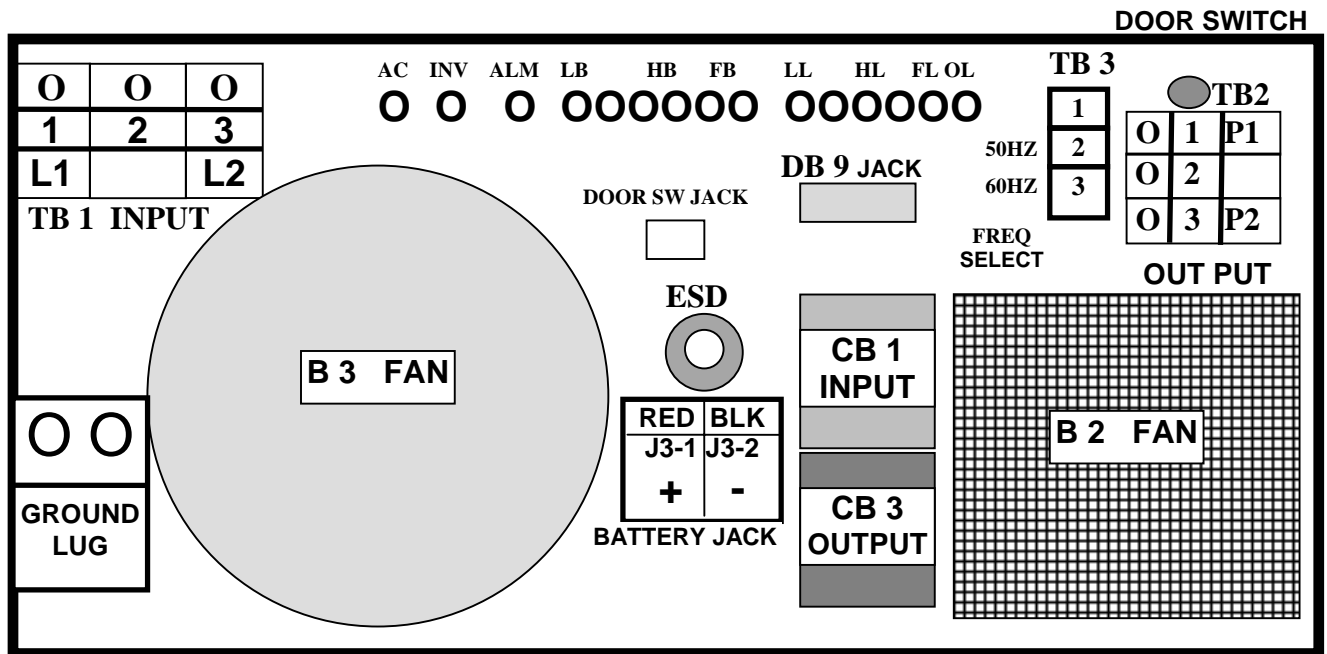

Electronics Tray ( Upper Tray ) IEC International Model  
Illustration 1-3A

Electronic Tray Top View (Upper Tray)  
ILLUSTRATION 1-4

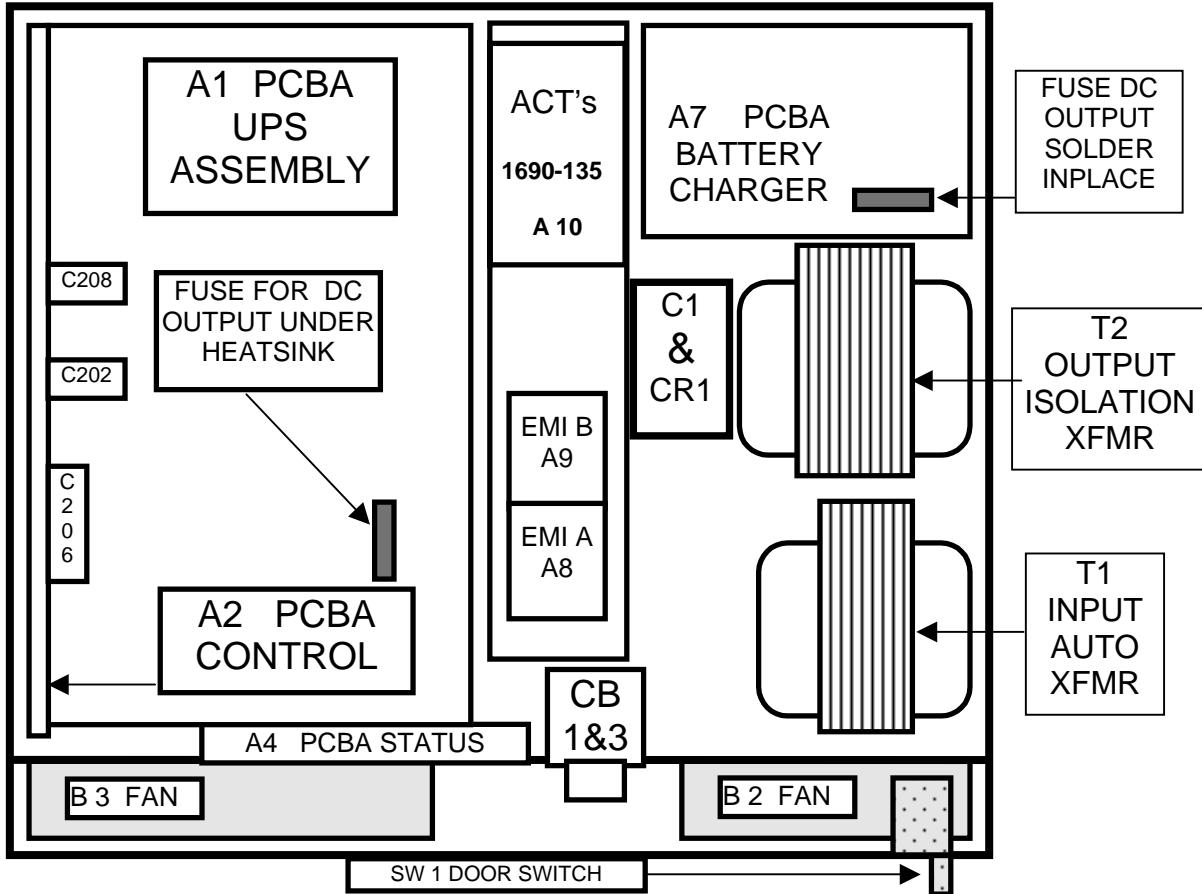

Electronic Tray Top View (Upper Tray) IEC International Model  
ILLUSTRATION 1-4A

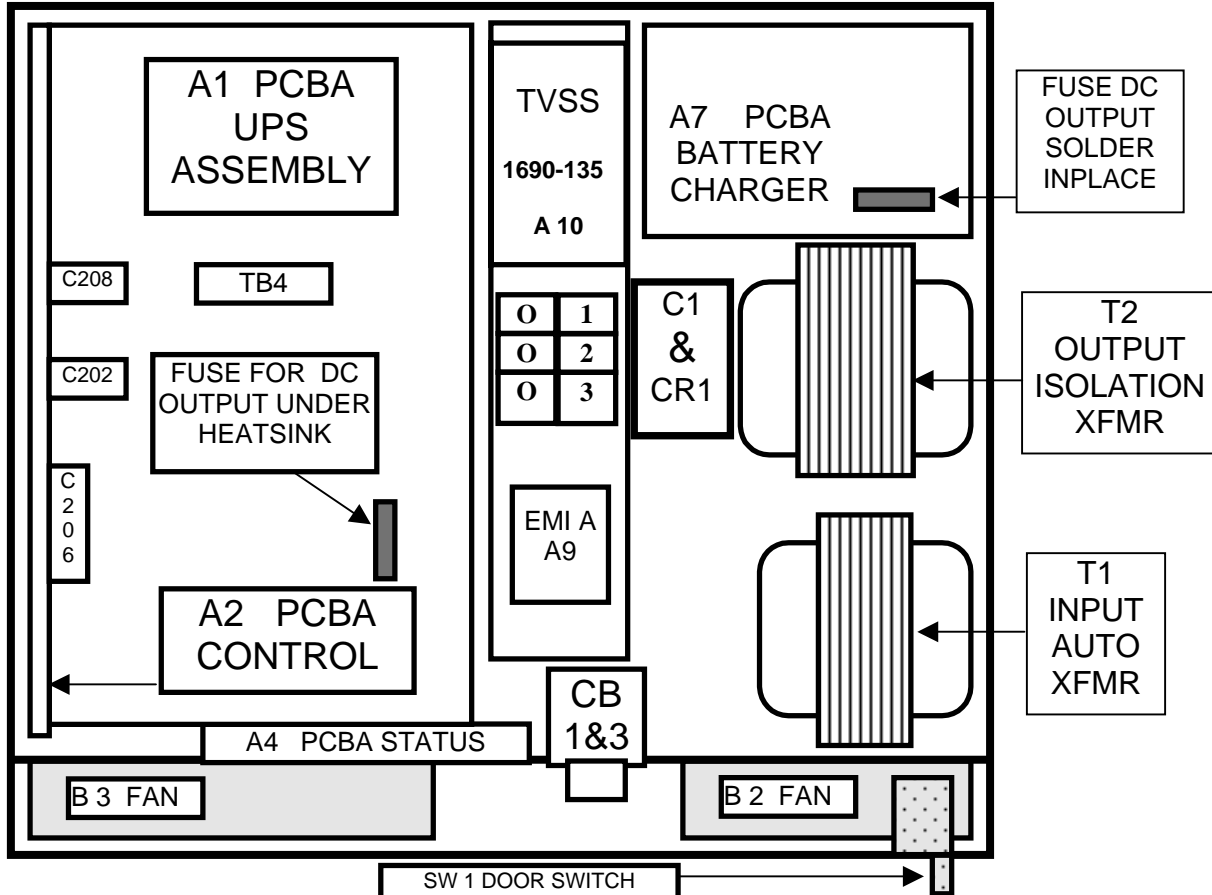

## Battery Tray

Houses the internal backup batteries:

The 650 W version, with 4 x 50A/hr batteries are mounted in the tray, supplying 48VDC to UPS.

The 1300 W version, with 6 x 50A/hr batteries are mounted in the tray, supplying 72VDC to UPS.

Also, the Battery Tray has the OPTION of heaters to ensure operation down to  $-40^{\circ}\text{C}$  where the batteries will be kept at a temperature of  $0^{\circ}\text{C} \pm 5^{\circ}\text{C}$ .

- The front view of the battery tray (see illustration 1-5).

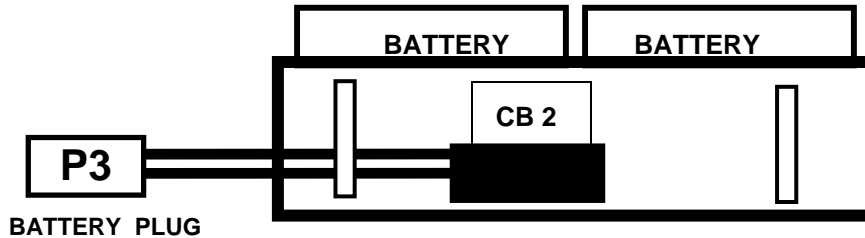

**Battery Tray (Lower Tray)**

**Illustration 1-5**

The simplified construction into two major components makes for fast and easy repair of the unit in the field where the batteries, Battery Tray, Electronics Tray composes the only FRU items within the unit.

- **Temperature Compensated Fast Battery Charger (A 7 PCBA)**

The Fast Charger will charge the batteries when discharged as well as to keep the batteries charged. The recharging time varies based on the backup time and the critical load supported by the batteries during the input power outage.

650 W uses 1625-229-01 Charger, 55 VDC @ 4 AMPS. approximate 1.8 watts.

1300 W uses 1625-229-02 Charger, 81 VDC @ 2.7 AMPS. approximate 1.8 watts.

- **Automatic Internal Bypass Switch**

The PBC has a UPS assembly designed to operate reliably for many years. However if there is an internal Inverter failure within the UPS, it will use the automatic internal bypass switch. This switch will bypass the inverter, when utility power is available via the transformers, to support the full rated load.

- **External Padlock**

The cabinet possesses an external padlock receptacle to prevent unauthorized personnel from gaining access to the interior of the cabinet via the front door when used in conjunction with a customer supplied padlock.

- **Over Temperature Shutdown**

While the PBC has several internal fans operating when the PBC & UPS Is " ON " to prevent an overheating condition, further protection has been built into the UPS to ensure against circuit failure due to internal overheating. If there is an Over Temperature condition, the UPS shall shut down. It has an auto-recovery feature, so that when the temperature reaches a safe level, the UPS will come back on. There is a built-in hysteric feature to prevent any oscillatory condition of the UPS turning " ON " and "OFF" at the Over Temperature trip point from taking place.

- **Over Current Protection**

If there is the load or loads draw excessive output current from the PBC. The sensing circuit in the Inverter will provide feedback to cause the Inverter to limit the current and thereby prevent the unit from being damaged due to such a condition.

### 1-8 Electrical - Input/Outputs

All Models are Single Phase Input and Output

Model Rating	Input Voltage A C	Input Frequency	Input 120 VAC Breaker	Input 240 VAC Breaker	Output Voltage	Output Frequency	Heater Pad
650 W	120 / 240 VAC	60 Hz 1 $\phi$	15 Amps	10 Amps	120 / 240 VAC	60 Hz 1 $\phi$	NO
650 W	220 / 230 VAC	50 Hz 1 $\phi$	15 Amps	10 Amps	230 VAC	50 Hz 1 $\phi$	NO
1300 W	120 / 240 VAC	60 Hz 1 $\phi$	30 Amps	15 Amps	120 / 240 VAC	60 Hz 1 $\phi$	YES
1300 W	220 / 230 VAC	50 Hz 1 $\phi$	30 Amps	15 Amps	230 VAC	50 Hz 1 $\phi$	YES
1300 W	120 / 240 VAC	60 Hz 1 $\phi$	30 Amps	15 Amps	120 / 240 VAC	60 Hz 1 $\phi$	NO
1300 W	220 / 230 VAC	50 Hz 1 $\phi$	30 Amps	15 Amps	230 VAC	50 Hz 1 $\phi$	NO
IEC International Model							
560 W	230 / 240 VAC	50/60Hz 1 $\phi$	2 Pole 10 AMP		230/240 VAC	50/60 Hz 1 $\phi$	Option
1300 W	230 / 240 VAC	50/60Hz 1 $\phi$	2 Pole 15 AMP		230/240 VAC	50/60 Hz 1 $\phi$	Option

**NOTE:** 1300W models IS de-rated to 400W UPS when used in; Sealed cabinet for environmental protection application, units have no louvers or when a sealing kit option is add to a louver unit.

### 1-9 Electrical - Output Characteristic: All Models are Single Phase Input and Output

Model Rating	Output Voltage	Frequency RANGE	Nominal Voltage	Maximum Current	Output Breaker
650 W	120 VAC $\pm$ 3%	57 - 63 Hz	120 VAC	5.4 Amps	15 Amps
650 W	240 VAC $\pm$ 3%	57 - 63 Hz	240 VAC	2.7 Amps	15 Amps
650 W	230 VAC $\pm$ 3%	47 - 53 Hz	230 VAC	2.8 Amps	15 Amps
1300 W	120 VAC $\pm$ 3%	57 - 63 Hz	120 VAC	10.8 Amps	15 Amps
1300 W	240 VAC $\pm$ 3%	57 - 63 Hz	240 VAC	5.4 Amps	15 Amps
1300 W	230 VAC $\pm$ 3%	47 - 53 Hz	230 VAC	5.65 Amps	15 Amps

**NOTE:** 1300W models IS de-rated to 400W UPS when used in; Sealed cabinet for environmental protection application, units have no louvers or when a sealing kit option is add to a louver unit.

### 1-10 Mechanical Overall Dimensions and Weight-Total Mechanical Details are shown in Section 2

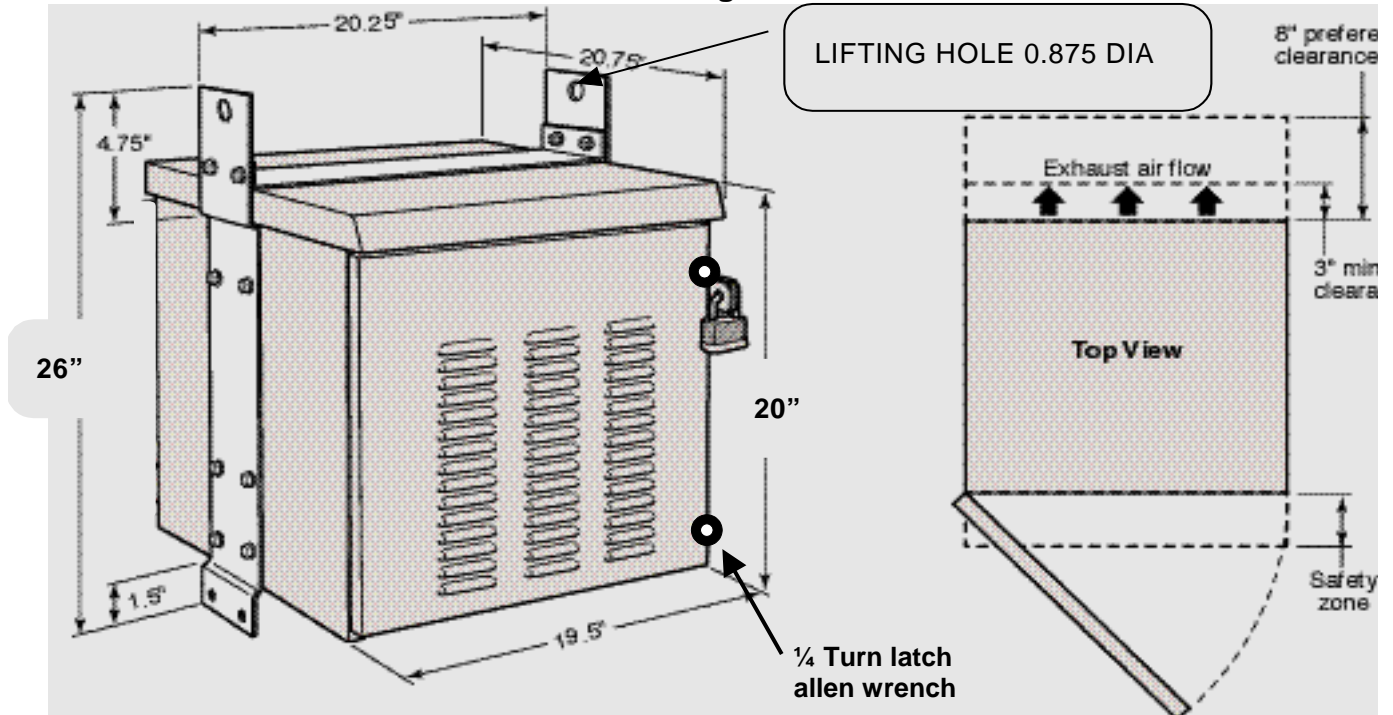

ILLUSTRATION 1-6 OUTLINE DIMENSIONS

## 1-11 Theory of Operation

Functional Block Diagram shows the power path through the PBC, See Illustration 1- 6.  
For domestic models and theory of operation 1-11A Illustration 1-6A for international models.

### Input Stage

- The utility company's power sinewave enters the system by way of TB 1.
- The ACT's, TVSS , supply input surge protection before CB-1A & CB-1B for domestic models.
- The CB-1A and CB-1B linked for common trip, CB-1A on 120V is rated for the higher current and CB-1B on 240V rated for the lower current on the domestic models.
- From the circuit Breakers to the 2 stages of EMI filters, network where attenuation of any power line noise occurs.
- On exiting the input filter, the AC voltage enters the Autotransformer and is stepped down to 120 VAC required by A1 PCBA UPS Inverter Module.

### The Power Splits Into Two ( 2 ) Directions

- Quick Battery Charger, A 7 PCBA, reduces the recharge time after the batteries after a power outage.
- The Power Conditioning UPS Module, A 1 PCBA.

### Power Conditioning Stage

- The Power Conditioning Module has 6 sections and their functions are follows:
- The power from the on board Battery Charger supplies a float charge to the Standby Reserve Battery System.
- The Emergency Bypass line connects the input to output by way of on board Emergency Bypass Switch.
- The Power Rectifier section provides DC Voltage to the DC Chopper.
- The  $\pm$  DC Choppers change DC Voltage from the power Rectifier and the batteries to a pulse Voltage for the DC/AC Inverter.
- The DC/AC Inverter supplies a Pulse Width Modulation Output through the Bypass Switch to the Output Filter.
- The Output Filter changes the Pulse Width Modulation to a clean sinewave and to the Output Isolation Transformer.

### Power Output Stage

- The Output Filter connects to the 2 Fans, B 2 and B 3, providing constant airflow to cool the Electronic Tray components, and to T 2, Output Isolation Transformer.
- The Output Isolation Transformer, T2, connects to CB-3 A and CB-3B, the Output Circuit Breaker and provides voltage to the terminals of TB-2 and the load.

### Power Outage Stage

If there is a power outage; the Standby Reserve Battery System supplies the power through CB-2 to the UPS. The Battery DC voltage enters the  $\pm$  DC Chopper, DC / AC Inverter, Bypass Switch and to the Output Filter, Output Transformer, CB 3, to TB 2, and the load.



PBC FUNCTIONAL BLOCK DIAGRAM FOR DOMESTIC MODELS

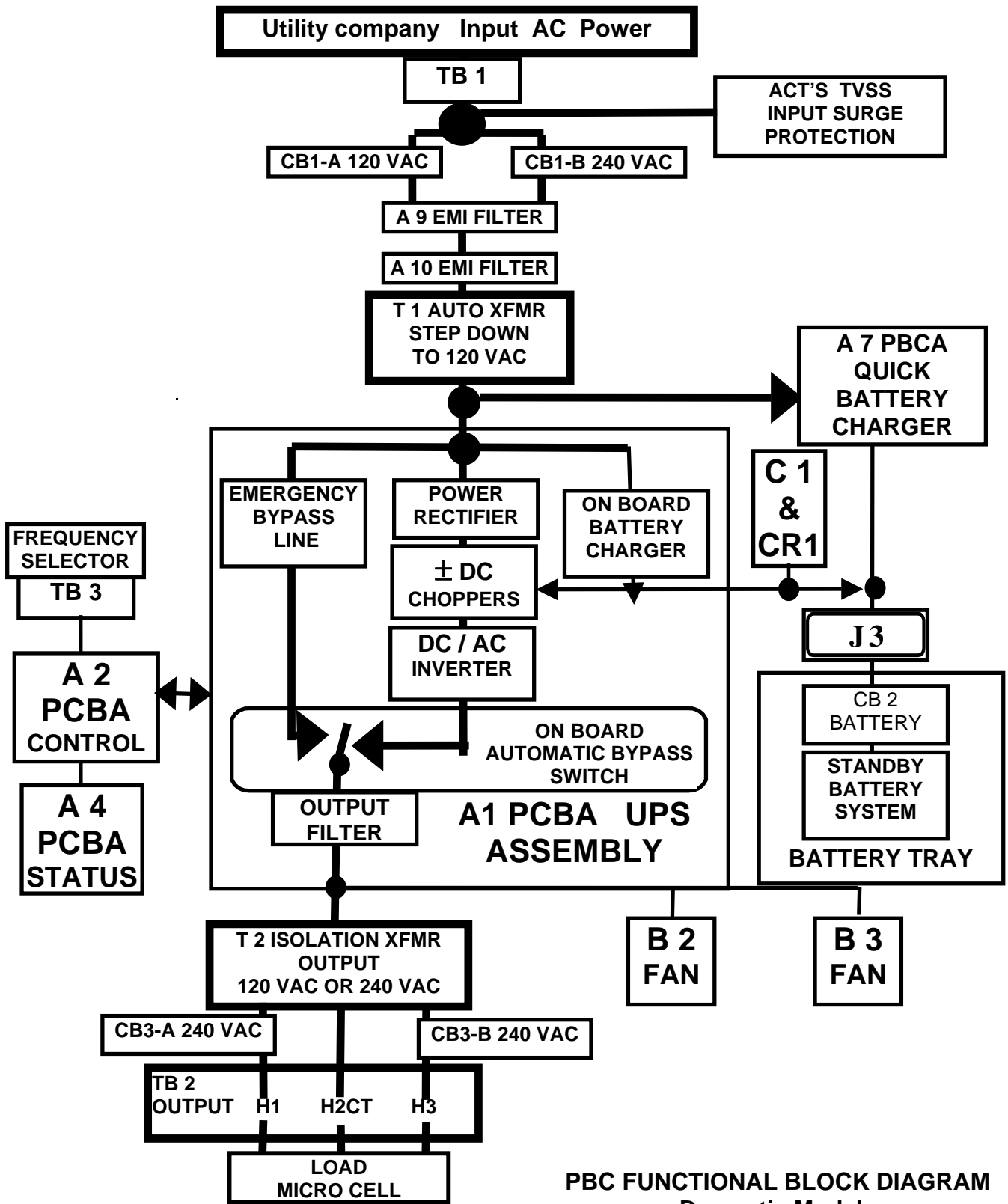

PBC FUNCTIONAL BLOCK DIAGRAM  
Domestic Models  
ILLUSTRATION 1- 6

## 1-11A Theory of Operation

Functional Block Diagram shows the power path through the PBC, See Illustration 1-6A for international models.

### Input Stage

- The utility company's power sinewave enters the system by way of TB 1.
- The CB-1 is a 2-pole breaker shown as CB-1A & CB-1B for international models.
- The Joslyn, TVSS, supply input surge protection, is after CB-1A and CB-1B for international models.
- From the Joslyn, TVSS at TB4 is the EMI filter, network attenuation of any power line noise occurs.
- On exiting the input filter, the AC voltage enters the Autotransformer and is stepped down to 120 VAC required by A1 PCBA UPS Inverter Module.

### The Power Splits Into Two ( 2 ) Directions

- Quick Battery Charger, A7 PCBA reduces the recharge time after the batteries after a power outage.
- The Power Conditioning UPS Module, A1 PCBA.

### Power Conditioning Stage

- The Power Conditioning Module has 6 sections and their functions are follows:
- The power from the on board Battery Charger supplies a float charge to the Standby Reserve Battery System.
- The Emergency Bypass line connects the input to output by way of on board Emergency Bypass Switch.
- The Power Rectifier section provides DC Voltage to the DC Chopper.
- The  $\pm$  DC Choppers change DC Voltage from the power Rectifier and the batteries to a pulse Voltage for the DC/AC Inverter.
- The DC/AC Inverter supplies a Pulse Width Modulation Output through the Bypass Switch to the Output Filter.
- The Output Filter changes the Pulse Width Modulation to a clean sinewave and to the Output Isolation Transformer.

### Power Output Stage

- The Output Filter connects to the 2 Fans, B 2 and B 3, providing constant airflow to cool the Electronic Tray components, and to T 2, Output Isolation Transformer.
- The Output Isolation Transformer, T2, connects to CB-3 A and CB-3B, the Output Circuit Breaker and provides voltage to the terminals of TB-2 and the load.

### Power Outage Stage

If there is a power outage; the Standby Reserve Battery System supplies the power through CB-2 to the UPS. The Battery DC voltage enters the  $\pm$  DC Chopper, DC / AC Inverter, Bypass Switch and to the Output Filter, Output Transformer, CB 3, to TB 2, and the load.

PBC FUNCTIONAL BLOCK DIAGRAM FOR INTERNATIONAL MODEL

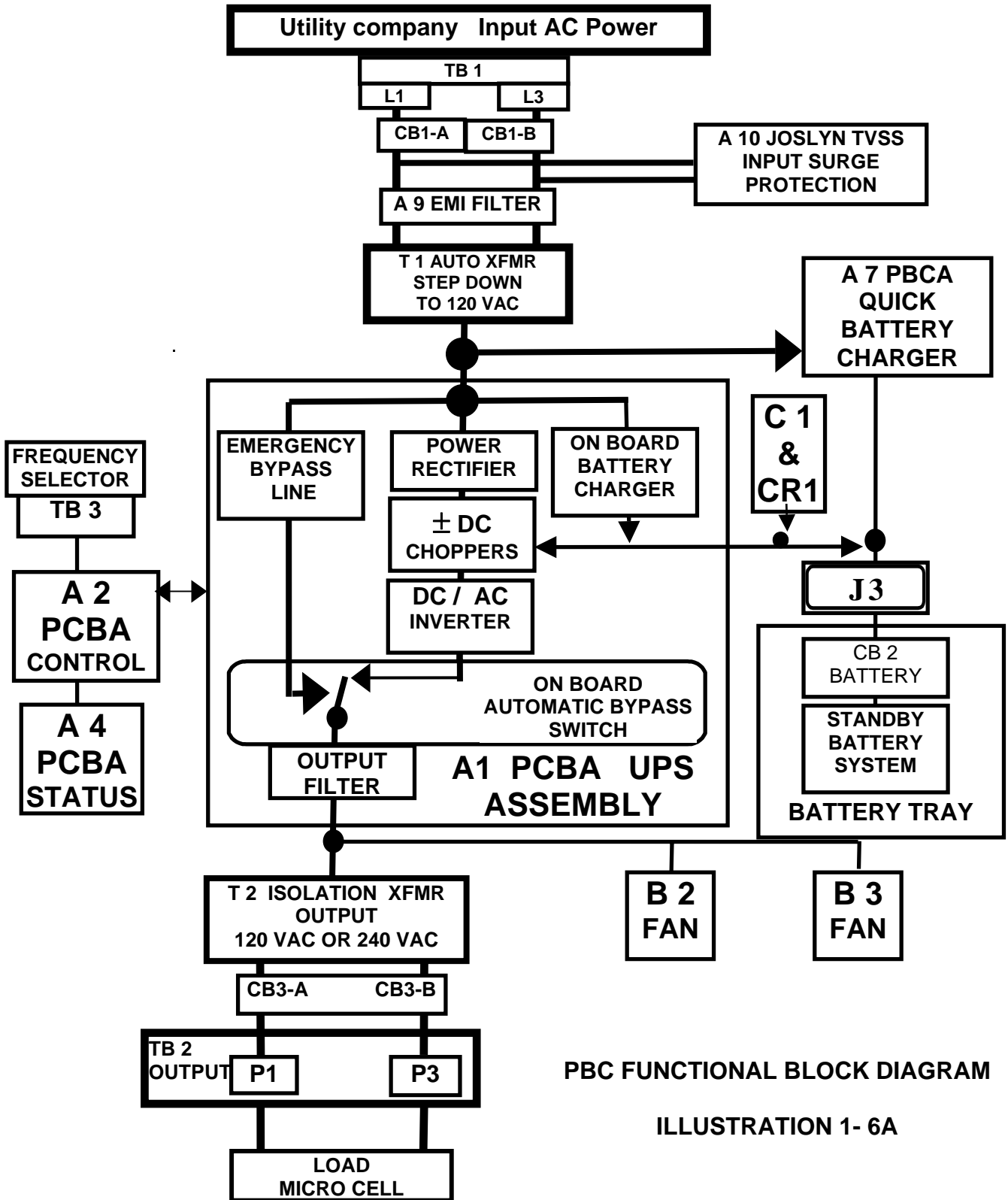

PBC FUNCTIONAL BLOCK DIAGRAM

ILLUSTRATION 1- 6A

## SECTION 2 – PREINSTALLATION

### 2-1 Location Considerations

- Provide an operating environment that meets the following conditions:  
Ambient Temperature is 0 °C to 40 °C ( 32 °F to 104 °F )  
Relative Humidity is 10 to 95 % Non-Condensing.

### 2-2 Positioning

- Allow at least a minimum of 3 inches to the rear for airflow. The PBC is air cool by convection.
- Door shall have full 110 degrees open clearance, and have 5 feet clearance in front for basket or platform.

**CAUTION !**

**DANGER**

- **Inspection Safety Zone of Tray is 6 inches. Pass that point the tray needs support, due to weight.**
- The Electronic Tray weight varies by model and is approximately 52 to 57 lbs.
- The Battery Tray weight varies by model and is approximately 200 to 290 lbs.
- The PBC varies by model and is approximately 365 to 455 lbs.

### 2-3 Mechanical Overall Dimensions and Weight

Model Rating	Maximum Cabinet Dimensions	Maximum Weight	Lifting Hole Diameter
650 W	19.5" W x 20" H x 20.75" D	365 lbs.	0.875
650 W	# 1 20.25" W x 26" H x 20.75" D	375 lbs.	0.875
650 W	# 2 20.25" W x 27.5" H x 20.75" D	385 lbs.	0.875
1300 W	19.5" W x 20" H x 20.75" D	455 lbs.	0.875
1300 W	# 1 20.25" W x 26" H x 20.75" D	465 lbs.	0.875
1300 W	# 2 20.25" W x 27.5" H x 20.75" D	475 lbs.	0.875

Note: # 1 PBC Height with Lifting & Pole Mounting Plates.  
# 2 PBC Height with Pad mounting Plates and Lifting Plates.

**NOTE:** 1300W models IS de-rated to 400W UPS when used in; Sealed cabinet for environmental protection application, units have no louvers or when a sealing kit option is add to a louver unit.

NO! Change in the weight of sealed cabinets units. Add 10 pounds to weight for Sealing Kit.

### 2-4 Site Planning Specifications

Nominal Input Voltage	220 VAC	230 VAC	120 VAC	220 VAC	240 VAC
Input Voltage Range	168 -- 264	168 -- 264	85 -- 132	168 -- 264	168 -- 264
Max. Input Voltage	264 VAC	264 VAC	132 VAC	264 VAC	264 VAC
Input Frequency *	50 Hz	50 Hz	60 Hz	60 Hz	60 Hz
Output Frequency	50 Hz ± 0.5 %	50 Hz ± 0.5 %	60 Hz ± 0.5 %	60 Hz ± 0.5 %	60 Hz ± 0.5 %
Output Voltage	230 VAC ±3%	230 VAC ±3%	120 VAC ± 3%	240 VAC ±3%	240VAC ± 3%

\* Factory pre-set. Can be selected for either 50 or 60 Hz.

### 2-5 Site Detail Electrical Specifications

- See page 7, Section 1-8 and 1-9 for more details.

## 2-6 Mechanical Overall Outline Dimensions

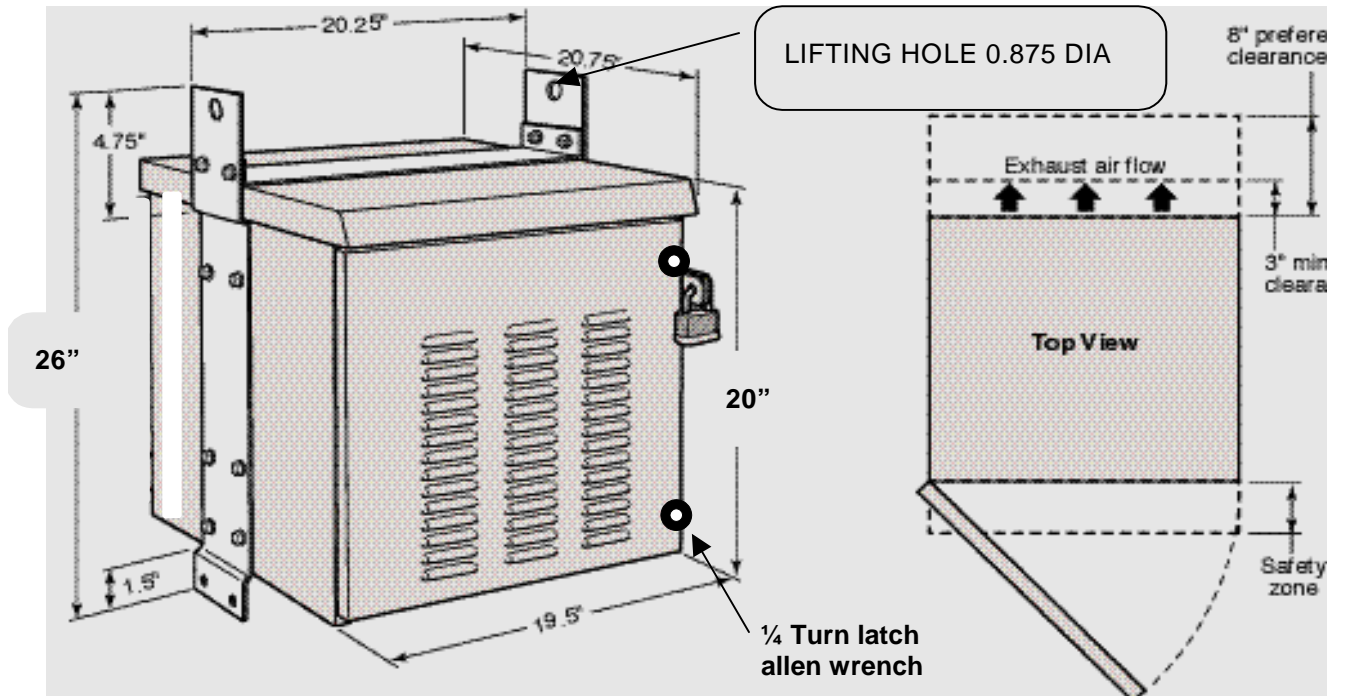

ILLUSTRATION 2-1 OUTLINE DIMNSIONS

## 2-7 Pad Mounting Layout

- Use M12 or 1/2 inch Anchor Bolts for mounting PAD Plate to Concrete Pad or Roof.
- Dimensions are inches.

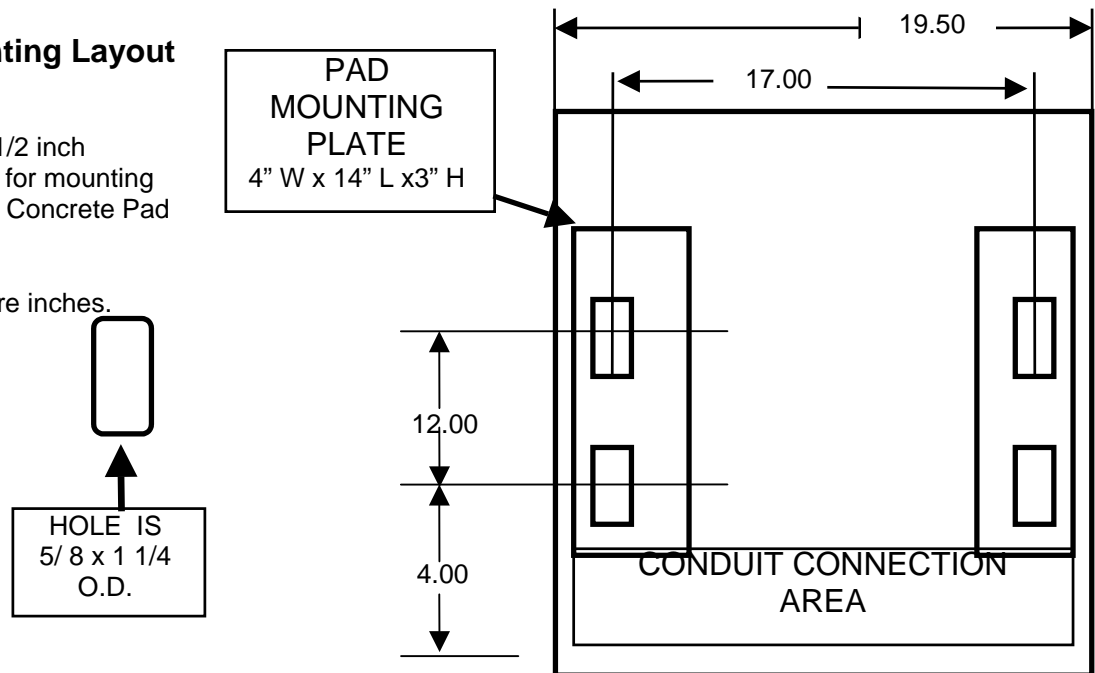

Illustration 2 – 2 ANCHORING HOLE PATTERN

- Details of conduit connection area are shown in Illustration 3 – 3

## SECTION 3 - PBC INSTALLATION

### 3-1 PBC Unpacking

- The unit is delivered on a pallet, secured using metal bands. On removing the PBC from the pallet, be sure to keep the protective wrapping in place. Use the following procedure to unpack the unit.
- Position the pallet away from walls or other obstructions.
- Be sure pallet is sitting level where bands cannot hit anything.



- **Exercise extreme caution as you cut the metal bands. They are under tension and may cause injury.**
- Carefully remove the cardboard cover from unit; avoid puncturing the plastic bubble wrap with any sharp object that may damage the surface of unit.
- The bubbles wrap covers the PCB and should be removed at location when the unit is to be mounted.
- Save the packing material to allow it to be used to keep the unit covered and protected until start-up.
- Place units in location where it's used, then remove protective plastic film.
- Before final positioning of unit, verify that all cable routing and raceway are in the correct position.

### 3-2 Inspection

- Inspect the PBC for obvious damage or safety hazards that may have occurred during shipping or handling of unit.
- Inspect all units when received and before use.
- Report any damage immediately to the originating factory, or to an authorized representative.
- Initiate Freight damage claims with the carrier soon as possible.
- Compare the contents and model numbers with the packing list to ensure that all of the items were received.

### 3-3 PBC Storage

- The batteries are installed before shipment of PBC for details of battery shelf time read appendix C.
- Provide a protected environment that meets the environmental limits listed below.
  - Storage and Transport Temperature Range is - 40°C to +60°C
  - Relative humidity: 0 % to 95 % non-condensing (inside cabinet).

## WARNING!

### Battery shelf life!

- Battery shelf life, when stored under temperature conditions of 66°F ~ 90°F, is five (5) months maximum after the ship date.
- For the battery shelf life details read appendix C.

### 3-4 PBC Installation - Installation of PBC has the following steps:

- The unpacking of PBC covered in section 3.1 & 3.2.
- The PBC installation and mounting.
- Connecting of conduit to PBC cabinet.
- Connecting DB-9 to control panel.
- Wiring input power to unit TB-1.
- Wiring output power from unit TB-2.
- Powering up the PBC unit & testing it.
- Power up the output circuits & checking loading.

### 3-5 Lifting Requirements

- Use Load - Rated Snaps on end of chain and a Spreader Bar.

#### **CAUTION !**

- Because the PBC Cabinets and it's contents, batteries, transformers, etc.... are extremely heavy, the use of Power Equipment is necessary.
- Total weight for 650W Model is 365 lbs.
- Electronic Tray weight is approximately 55 lbs.
- The Battery Tray weight, with a set of 4 batteries, is approximately 200 lbs.
- Power Backup Cabinet weight is approximately 85 lbs.
- Pole/Wall mount adapter plates with hardware is approximately 28 lbs.
- Pad/Roof adapter plates with hardware is approximately 14 lbs.
- Total weight for 1300W Model is 455 lbs.
- Electronic Tray weight is approximately 57 lbs.
- A Battery Tray with a set of 6 batteries weighs approximately 290 lbs.
- Power Backup Cabinet weight is approximately 85 lbs.
- Pole/Wall mount adapter plates with hardware is approximately 28 lbs.
- Pad/Roof adapter plates with hardware is approximately 14 lbs.

#### **CAUTION !**

**At least two persons should lift the battery tray and the electronics tray.**

### 3-6 PBC Pole Installation

- With the successful completion of the unpacking of the PBC, proceed to next step, which is the mounting of the unit to the pole.
- Ensure that all of the appropriate hardware is available for the mounting (See Appendix B for list of components supplied with the Accessory Kit and ensure that Pole Mounting Brackets and hardware are available.
- See Illustration 3-1, which shows the mounting of the unit to the pole, and Table 3.1 for the part numbers of the required parts.
- For the mounting of the weldments on the pole, see Illustration 3-1 for assembly details.
- Check to see the center to center spacing of the weldments is correct, and the bolt hole alignment matches.
- Using the lifting eyes on the top of the unit, rig the unit for lifting with the PBC in balance and level from side to side is correct.
- Install the bottom bolts first and tighten. Leave the bolt a little loose to permit some play.
- Install the top bolts and tighten, leave the bolt a little loose to permit some play.

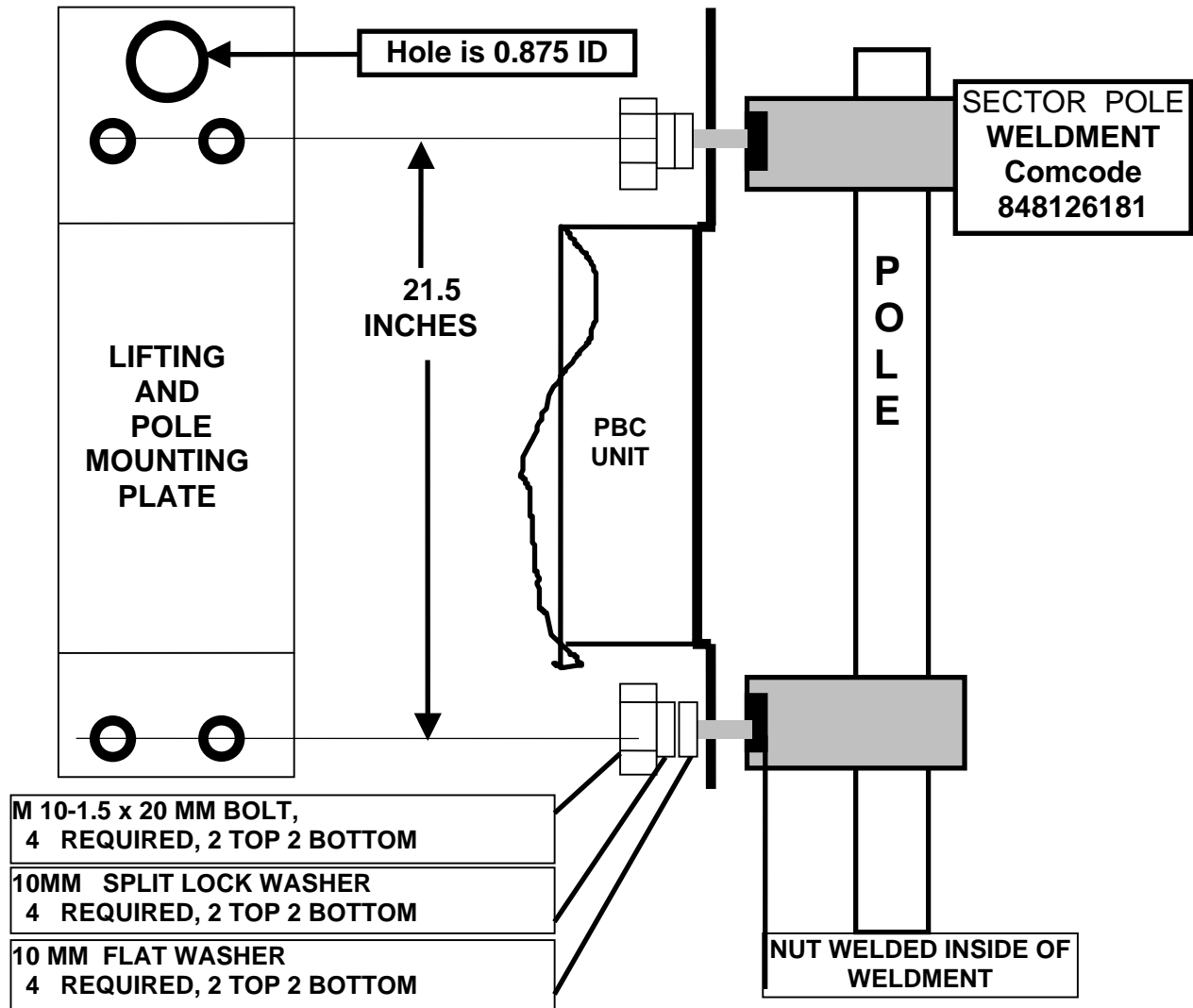

**SIDE VIEW PBC POLE MOUNTING  
ILLUSTRATION 3 - 1**



### 3-6 PBC Pole Installation (continued)

- Mount the Sector Pole Weldment, 4 Required in at each level, at the top position on the Pole.
- Mount the Sector Pole Weldment, 4 Required in at each level, at the bottom position on the Pole.
- Ensure the Weldment are level and at the 21.5 inches spacing, See Side View PBC Pole Mounting in Illustration 3-1.
- Check that the bolt hole's alignment matches, and the surfaces are parallel to each other.
- The PBC is now ready for rigging to lift in place with a power hoist.
- Connect the lifting Spreader Bar, with the Load -- Rated Snaps to the lifting Eyes, in the top of Pole Mounting Plate on each side of the cabinet.

### CAUTION !

- Carefully lift the PBC to the proper height to be able to slip the bottom bolts of mounting plate into the lower Weldment nuts.
- Tighten the bolt only hand tight to permit some play while installing the top Weldment bolts.
- Tighten the all bolt's to a torque of 28.5 ( N<sup>2</sup> m ) apply one drop of Torque-Seal ® to each bolt.

### 3-7 Power Backup Cabinet to Pole Grounding

- The details of installation of the ground connections are shown in Illustration 3-2.
- Install the ground jumper and ground cables as shown in Illustration 3-2 and Table 3-1 Ground Kit.
- Inspect the ground connection in the lower left, rear corner of the cabinet to the door at the hinge side.

**TABLE 3 - 1 POLE MOUNTING CABINET GROUND KIT**

ITEM	DESCRIPTION	QTY	OLP P/N
1	Compression Connector, 6 AWG, 2 Hole Lug	2	1200-182
2	M 6 x 16 mm, Screw, Hex Head, S.S.	4	1800-300
3	M 6, Washer, Split, S.S.	4	1825-085
4	M 6, Washer, Flat, S.S.	4	1825-084
5	6 AWG, Wire Stranding, Green, Grounding by 26 inches	2	4000-090
6	2 AWG, Wire Strand, Green, Grounding Buss, reference only Contractor Supplied.	x	Contractor Supplied
7	C-Tap, 12-1/0 Awg Burndy	2	1200-171

### 3-8 Power Backup Cabinet Grounding Test

- Inspect the ground jumper and ground cable connections for good crimp, shown in Illustration 3-2.
- Inspect the ground connection in both rear corners of the cabinet to the lower left, rear corner of the door at the hinge side.
- Inspect the M 6 hex head screws for torque of 7.7 ( N<sup>2</sup> m ) compression lugs on lower rear corners.
- Inspect the Electronic Tray ground strap to the cabinet at the upper left corner of the door.
- Tighten the all bolt's to a torque of 7.7 ( N<sup>2</sup> m ) apply one drop of Torque-Seal ® to each bolt.

### 3-8 Power Backup Cabinet Grounding Test

- Grounding Test requires a Digital Multimeter similar to a Fluke model 87 True rms. MULTIMETER,
- With a MULTIMETER check the resistance between the ground pole cables to the grounding of the cabinet door the reading shall be less than 0.01 ohms.
- With a MULTIMETER check the resistance between the ground pole cables to the grounding of the Battery Tray the reading shall be less than 0.01 ohms.
- With a MULTIMETER check the resistance between the ground pole cables to the grounding of the Electronic Tray the reading shall be less than 0.01 ohms.

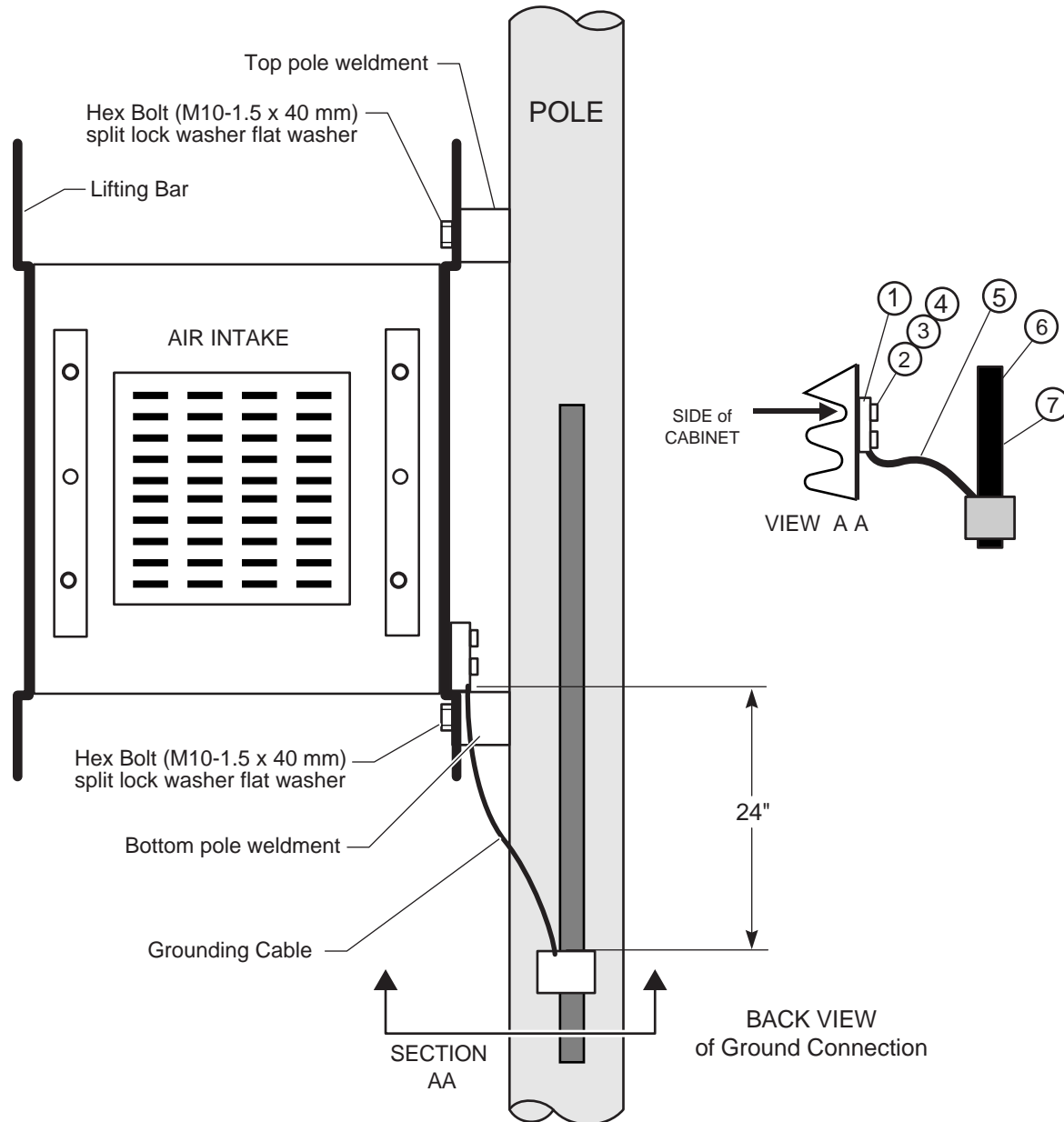
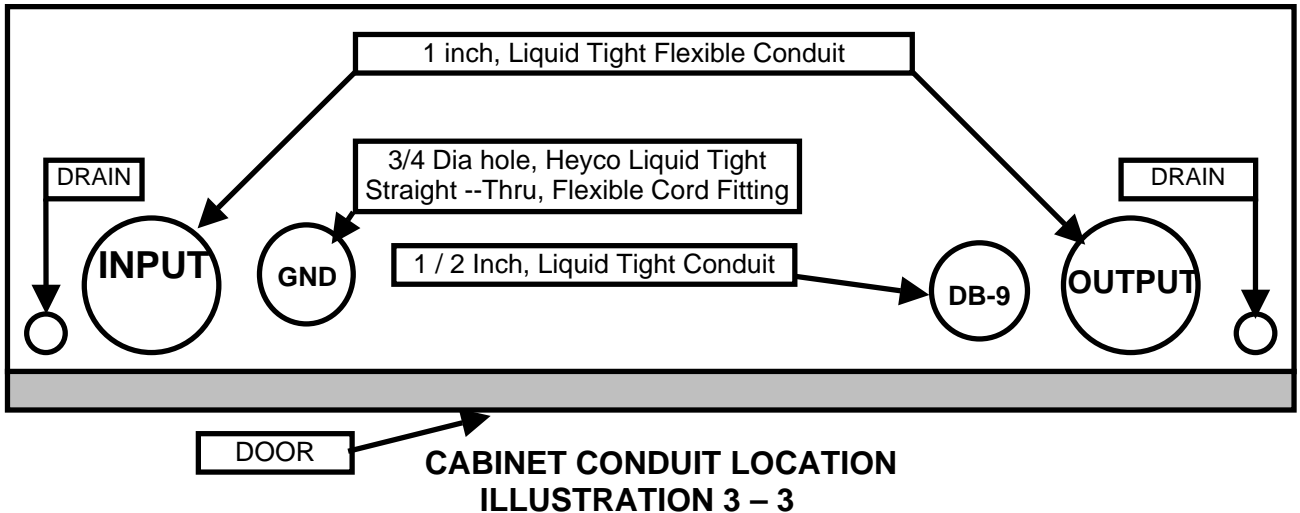

**ILLUSTRATION 3 – 2: POLE CABINET GROUNDING**

**CAUTION!!!: Make sure ALL POWER to PBC is Tagged Out & LOCK " OFF " Before working on the Power Backup Cabinet Electrical System.**

### 3-9 PBC Conduit Installation

- Install the Three, 3, Liquid-tight conduits, a Flexible cord, Plastic Liquid tight fitting (provided in the unit's accessory kit) into the bottom of the cabinet.
- Make sure the Liquid tight Seal ring is on the conduit fitting, then install it through the hole in bottom of cabinet and add the Lock-nut .
- Check to make sure that all lock nuts are tight and the Flex to fitting connectors are tight.



- See Illustration 3 - 3 for the fitting location.
- Install the wiring provided in the PBC Installation Accessory kit, as required according to your installation plan.

### 3-10 Electronic Tray Wiring - DB-9 cable

- Connect the signal cable with the Male DB-9 to the DB-9 jack, female on the Electronic Tray.
- See Illustration 1- 3 for location of the DB-9 location on the front panel.
- Route the DB-9 signal cable TAGED END through the 1/2 inch conduit to the auxiliary cabinet.
- In the auxiliary cabinet strip the insulation back of the DB-9 cable and attaches according to your installation plan.
- Route the Black of Black / Blue Wires of DB-9 cable to the PDC Door Switch cable, per your installation plan.
- Attach the 1 Red Quick Disconnect, DV18-188B-C, to the Pin # 1 wire, Black of Black / Blue Wires, tagged door open, attaches according to your installation plan to one side of the door switch.
- Attach the 1 Red Quick Disconnect, DV18-188B-C, to the Solid wire of the PDC Door Switch cable, Door Open SW attaches according to your installation plan to the other side of the PDC Door Switch.
- Route the Blue of Black / Blue Wires of DB-9 cable to the auxiliary cabinet punch down block, per your installation plan.

- Route the other 6 wires of cable to the punch down block are the correct length and attaches according to your installation plan.
- Route the of DB-9 cable wires to the PDC Door Switch cable correct length to reach the punch down block or Faston Terminal.

### Ground Cable

- Route the Green wire up through the Gray Heyco fitting to the Ground lug on Electronic Tray.
- The torque shall be 45 lbs./Inch on Screw.

### Frequency Selector Jumper

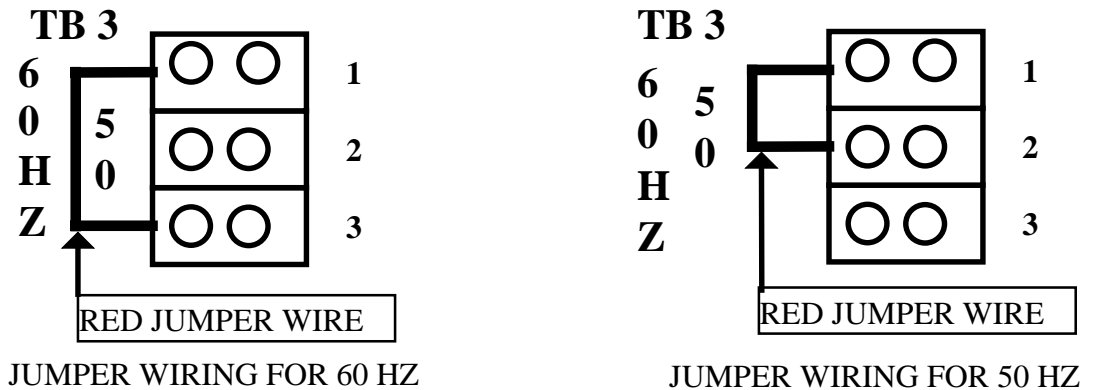

**FREQUENCY JUMPER LOCATION  
ILLUSTRATION 3 - 4**

NOTE: FREQUENCY JUMPER ARE INSTALLED AT THE FACTORY AND CAN BE CHANGED IN THE FIELD.

NOTE: FREQUENCY TB 3 SHOWN BELOW IS FOR LOCATION ONLY DETAILS OF SETTING SHOWN ABOVE.

### 3-11 Electronic Tray, Input & Output Wiring

**CAUTION !**

**Application of 240 VAC to the wrong terminals will cause damage to the unit.**

**Green 8 awg wire from TB 3 - 2 to the ground lug is required by UL.**

**Wiring Designation:**

Input	Output
L 1 - Hot line	L 1 - Hot line
L 2 - Hot line	L 2 - Hot line
N - Neutral	N - Neutral
Gnd-Ground	Gnd-Ground

### 3-11 Electronic Tray, Input & Output Wiring (continued)

#### 1. 120 VAC Input by 120 VAC Output:

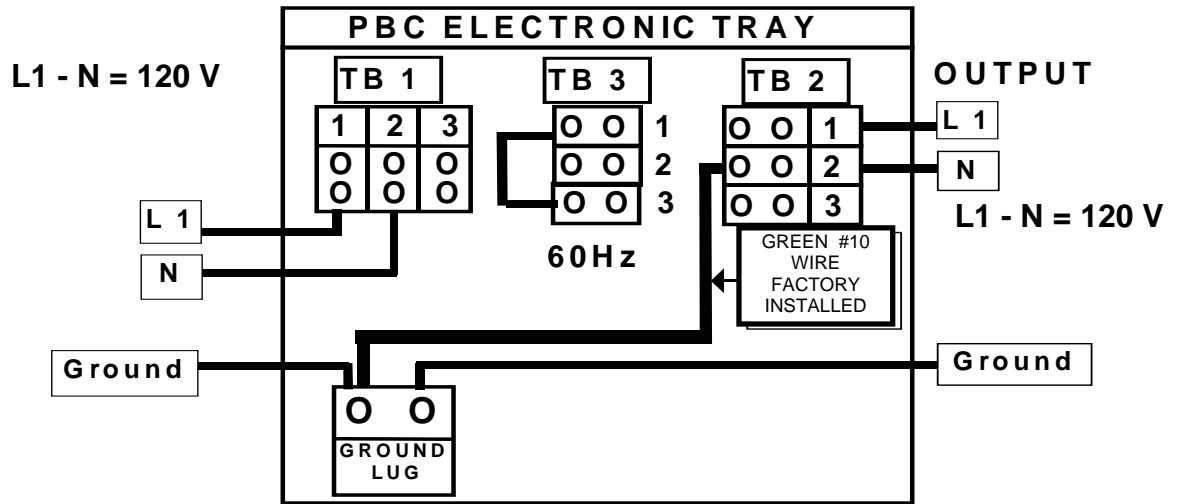

#### 2. 120 VAC Input by 120/240 VAC Output :

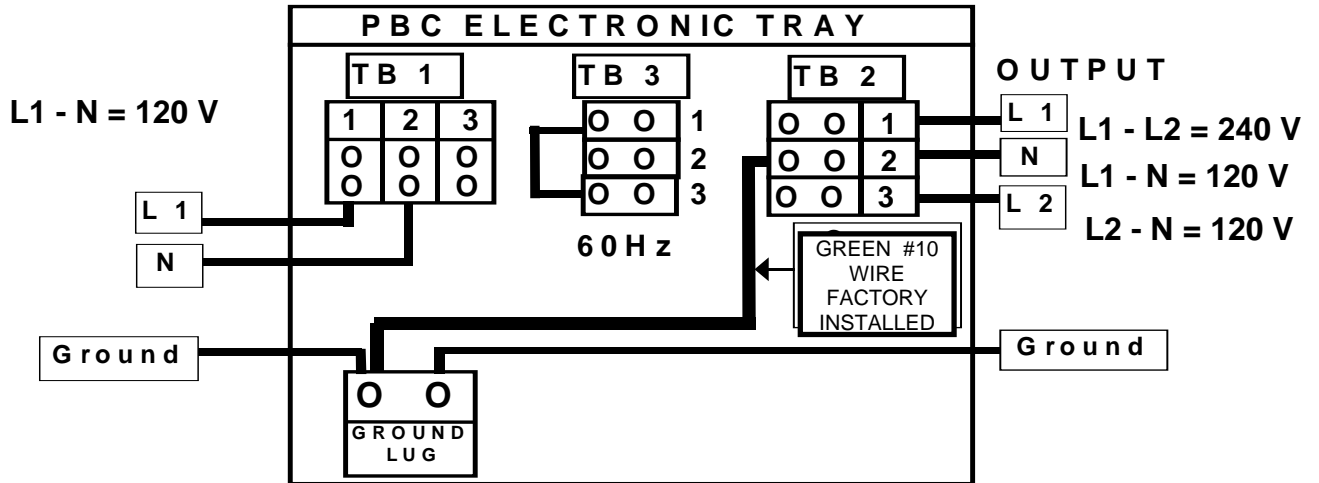

#### 3. 240 VAC Input by 120 VAC Output :

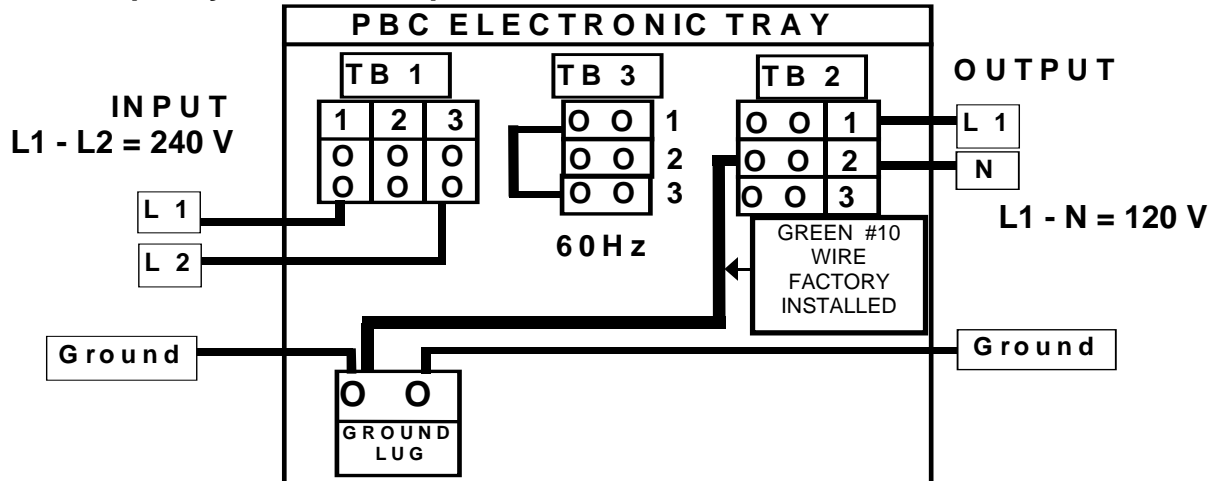

4. 240 VAC Input by 120 / 240 VAC Output:

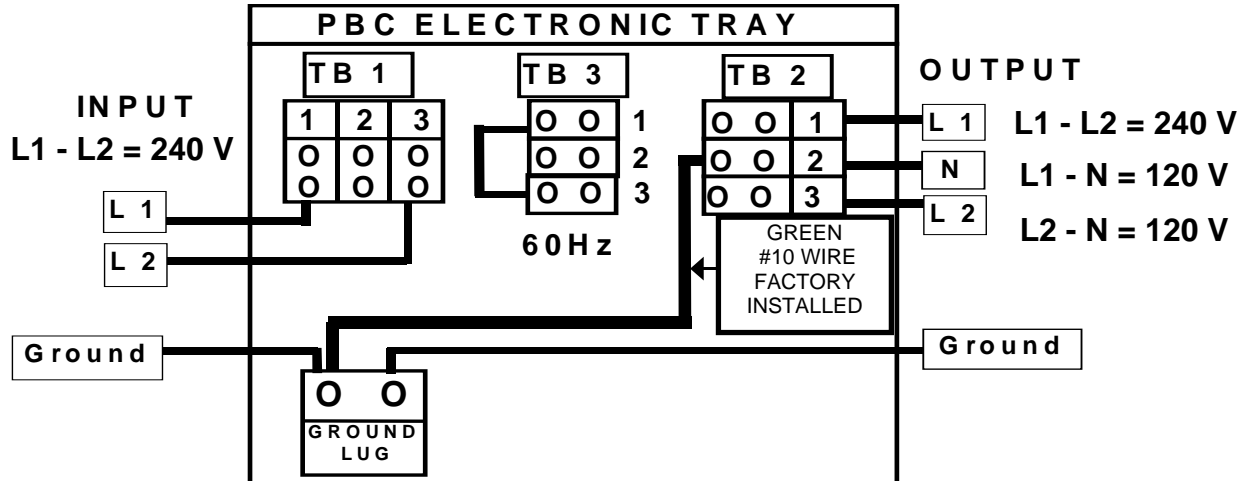

5. 220 VAC Input by 230 VAC Output:

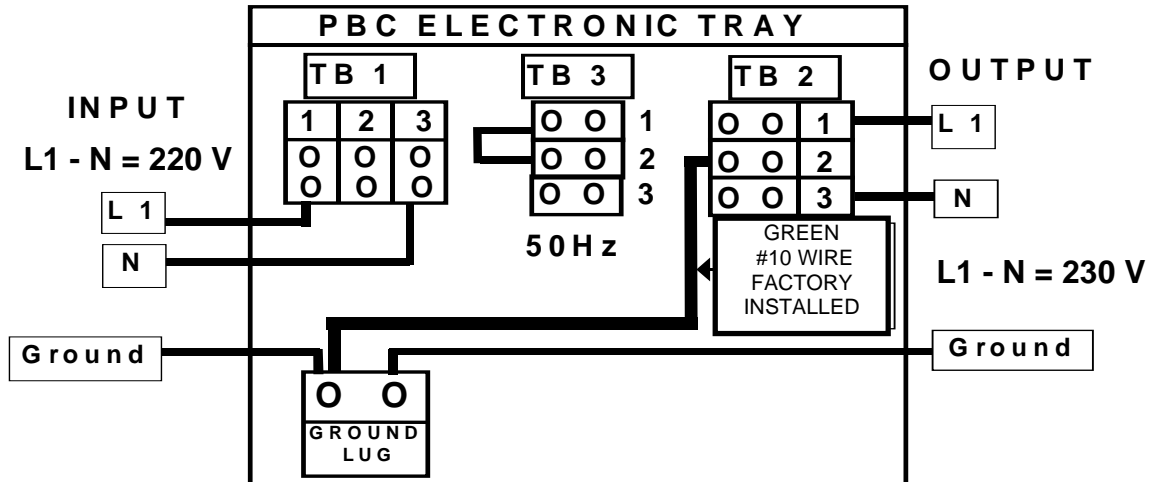

6. 230 VAC Input by 230 VAC Output:

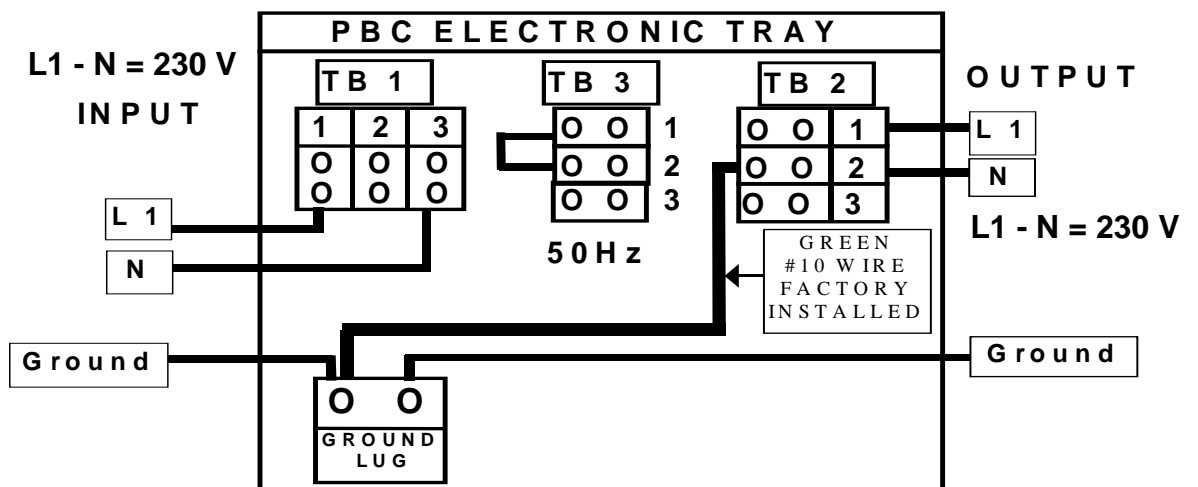

# CAUTION !

Application of 240 VAC to the wrong terminals will cause damage to the unit.

Input and Output wiring for special models at Lime Peru.

## 7. 240 VAC Input by 120/240 VAC Output:

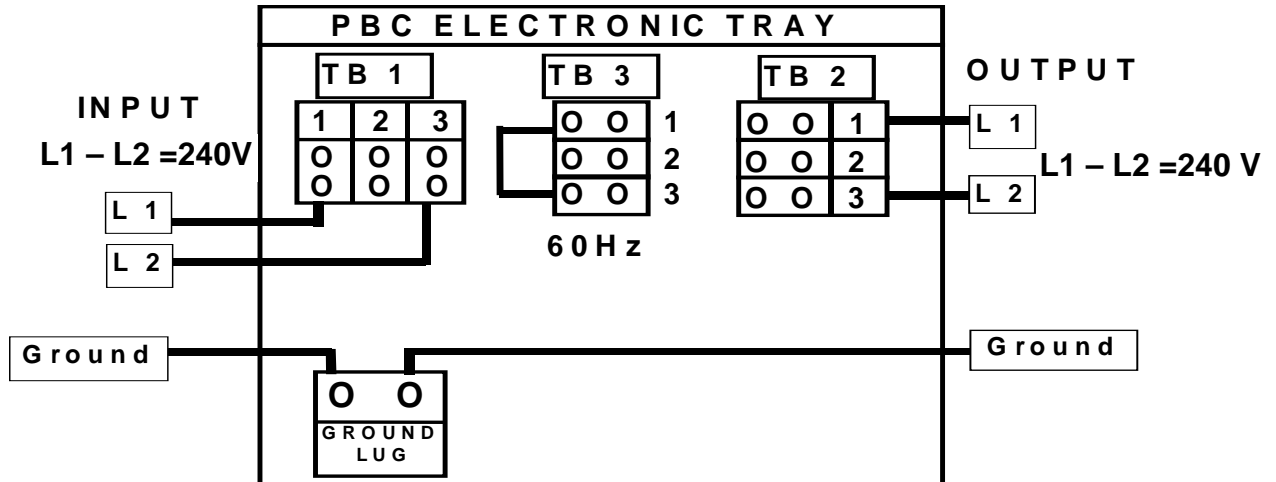

## 3-12 Electronic Tray, Output Wiring to Heaters:

- Heater's Input power comes through the white 2 pin socket:
- Heater's Input is 200 to 240 VAC from TB 1 input terminals 1 and 3.
- Heaters are in the bottom of the Battery Tray under the batteries.
- The Heaters connect in series as shown below, with a 2 pin plug.

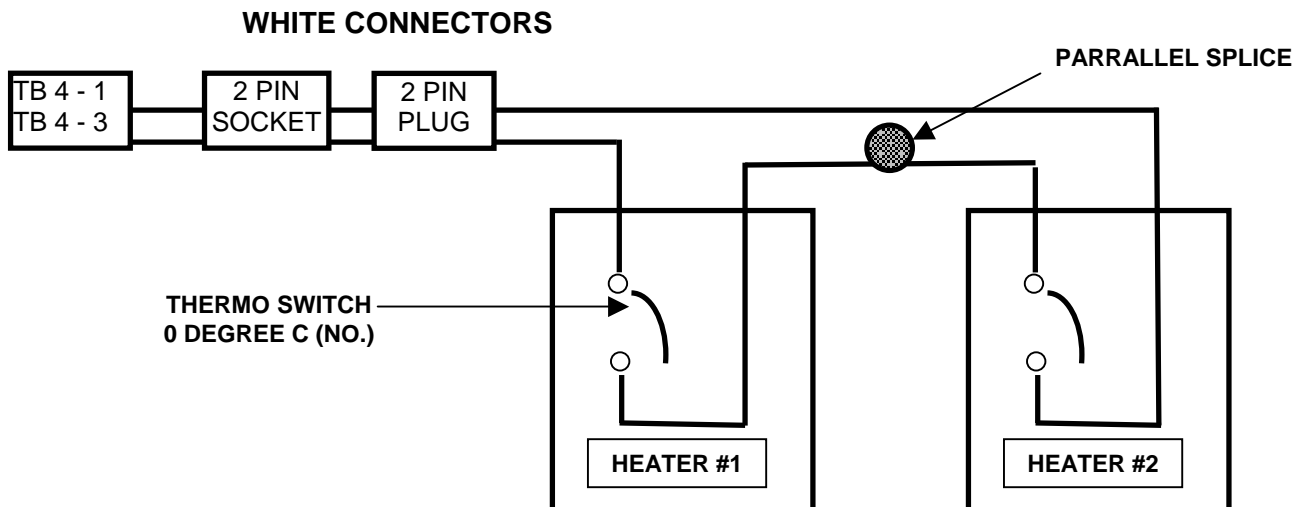

### 3-12 Electronic Tray, Output Wiring to Heaters:

- Heater's Input power comes through the white 2 pin socket:
- Heater's Input is 100 to 120 VAC from TB 1 input terminals 1 and 3.
- Heaters are in the bottom of the Battery Tray under the batteries.
- The Heaters connect in series as shown below, with a 2 pin plug.

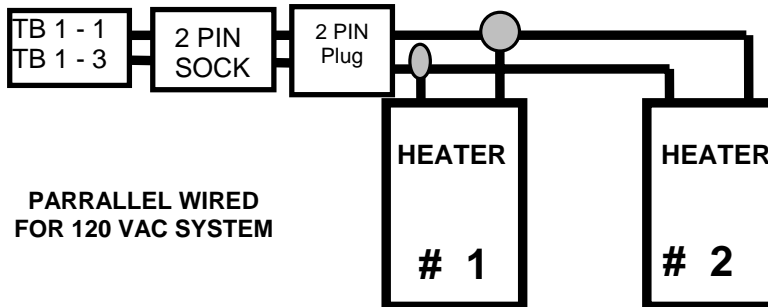

### 3-13 Electronic Tray, Wiring Check Out:

- Verify the input and output connections are per wiring detail in section 3-11 for the Model being in stalled.
- Verify the input and output TB 1 & TB 2 have been torque to value below:
- Screw torque shall be 35 lbs./ in, ( 4.0 N<sup>2</sup> m ) for TB 1 & TB 2.
- Screw torque shall be 45 lbs./ in, ( 5.1 N<sup>2</sup> m ) for Ground lug.
- Verify the Frequency Jumper on TB 3 is correct for the Model being installed. See Illustration 3 - 4.
- Verify the Frequency Jumper on TB 3 is correct for the Model being installed (See Illustration 3-4).

### 3-14 PBC Battery Tray Connection

- Check that BLACK & RED plug from the battery tray is in the battery jack on the electronic tray.
- Engage the heater's plugs on the models with battery heaters.

### 3-15 PBC is ready for Normal operational check

- Check CB 1, CB 3, and CB 2 is in the "OFF" position.
- Now is the time to remove Safety Tagouts, and turn "ON " the installation Power Distribution Circuit Breakers to " ON ".
- Measure the AC Input voltage at TB-1, is correct for the model installed.
- Turn CB1 to the "ON" position.
- Check the AC input voltage is into the PBC is proper for this Model. The Green "AC ON " LED shall be " ON ".
- The Green "INV ON" LED will turn "ON", after about 5 seconds.
- Turn CB 2 to " OFF ", the Red " LB " LED will be "OFF" and al green, battery level, LED's should be " ON ".
- Turn CB 2 to " ON ", the Red " LB " LED shall turn "OFF" and Green, battery level; LED's shall turn " ON ". Note: From 1 to 5 Green, battery level, LED's will be on depending on battery voltage level.
- With a Digital Voltmeter check the battery voltage across the RED & BLACK plug terminals.
- The 650W model the DC voltage shall be 48 VDC. The 1300W model the DC voltage shall be 72 VDC.

NOTE: 5 Green, battery level, LED's relate to % of battery voltage. Red "LB" led is low battery warning, will be "ON" only when system has been on inverter for a long period of time and battery voltage has reached the low limit set point.



### 3-16 PBC Unit is now ready for to Check Battery Back-up Operation.

- Battery Tray shall be powered up for 24 to 48 hours before the battery back-up Operational Test.
- After battery discharge, the batteries shall be recharged for 24 hours.
- Turn "CB1" to the "ON" position and turn AC input breaker to "OFF".
- The Green "AC ON" LED shall go to "OFF" and the Green "INV ON" LED will stay "ON".
- The "BATTERY LEVEL" shall LED's will be "ON".
- Turn AC input voltage "ON". The Green "AC ON" LED shall go to "ON".
- The Green "INV ON" LED will stay "ON". The Green "BATTERY LEVEL" shall stay "ON".
- Turn CB 3 to "ON".
- With a Digital Voltmeter check the output voltage.
- Apply the load in steps. The Green "LOAD LEVEL" LED's will light in succession as additional load increases.
- See Appendix C for battery evaluation.

### 3-17 The Backup Power Cabinet is ready for usage.

### 3-18 PBC Pad Layout.

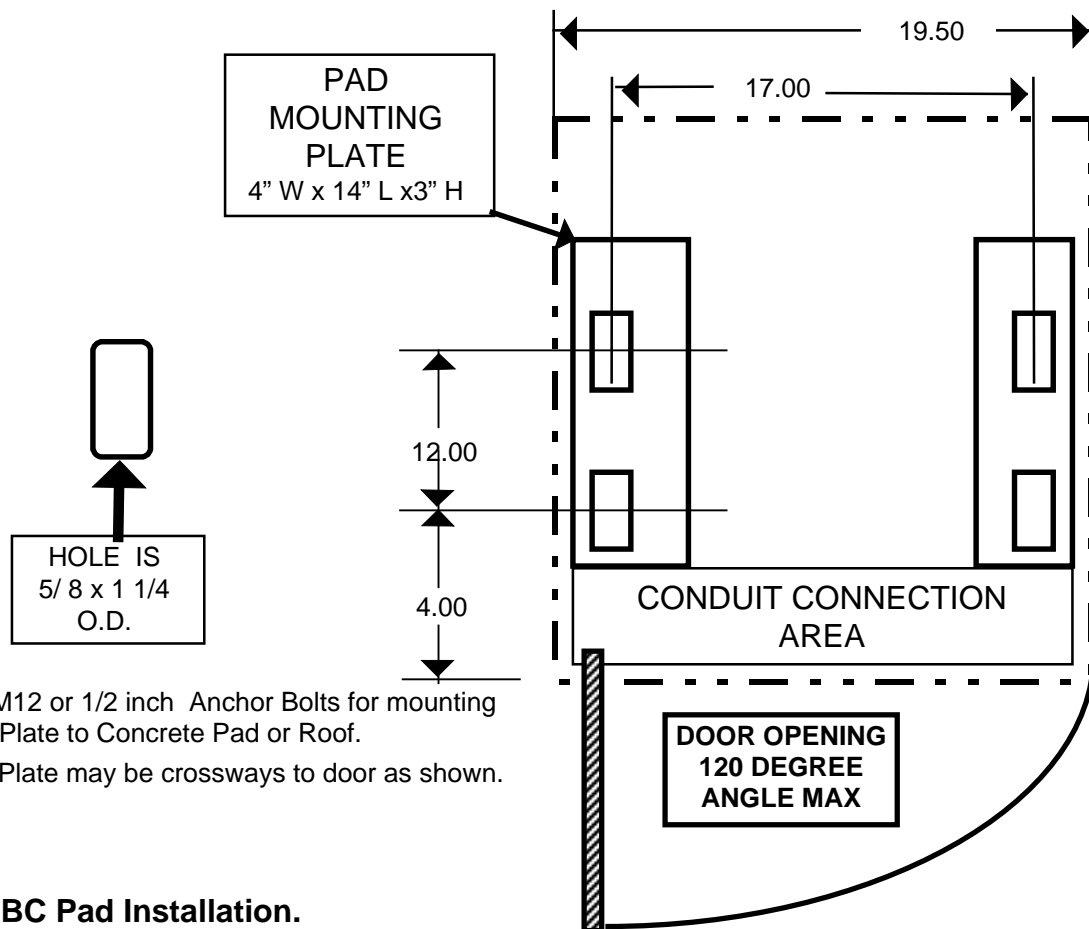

- Use M12 or 1/2 inch Anchor Bolts for mounting PAD Plate to Concrete Pad or Roof.
- PAD Plate may be crossways to door as shown.

### 3-19 PBC Pad Installation.

- Verify Center spacing of mounting bracket bolts are correct.
- Carefully lift the Cabinet into place on pad over the mounting bolts
- Verify Pad mounting brackets bolts have been torque to 165-inch lbs.
- Install the Conduits to the bottom of the Cabinet; follow directions in 3-9 and Illustration 3-3.
- Install the Cabinet to the Pad, and then use section 3-10 through 3-12 for electrical wiring.
- Check out the Electronic Tray wiring using Section 3-13 & Battery Tray connections per 3-14.
- PBC is ready for Normal operational Check out using Section 3-15 thru 3-17.

## SECTION 4 - SERVICING THE POWER BACK-UP CABINET

### 4-1 The modularity of internal componets.

- The two basic physical assemblies are the Electronic Tray and Battery Tray.
- Each can be removed for servicing or repair, your spare assembly can be installed in minutes.
- Illustration 4.1 shows the location of Hold Down Bolts which hold the trays in place.
- Read the removing and replacing of Electronic Tray or Battery Trays on page 24 and 25.

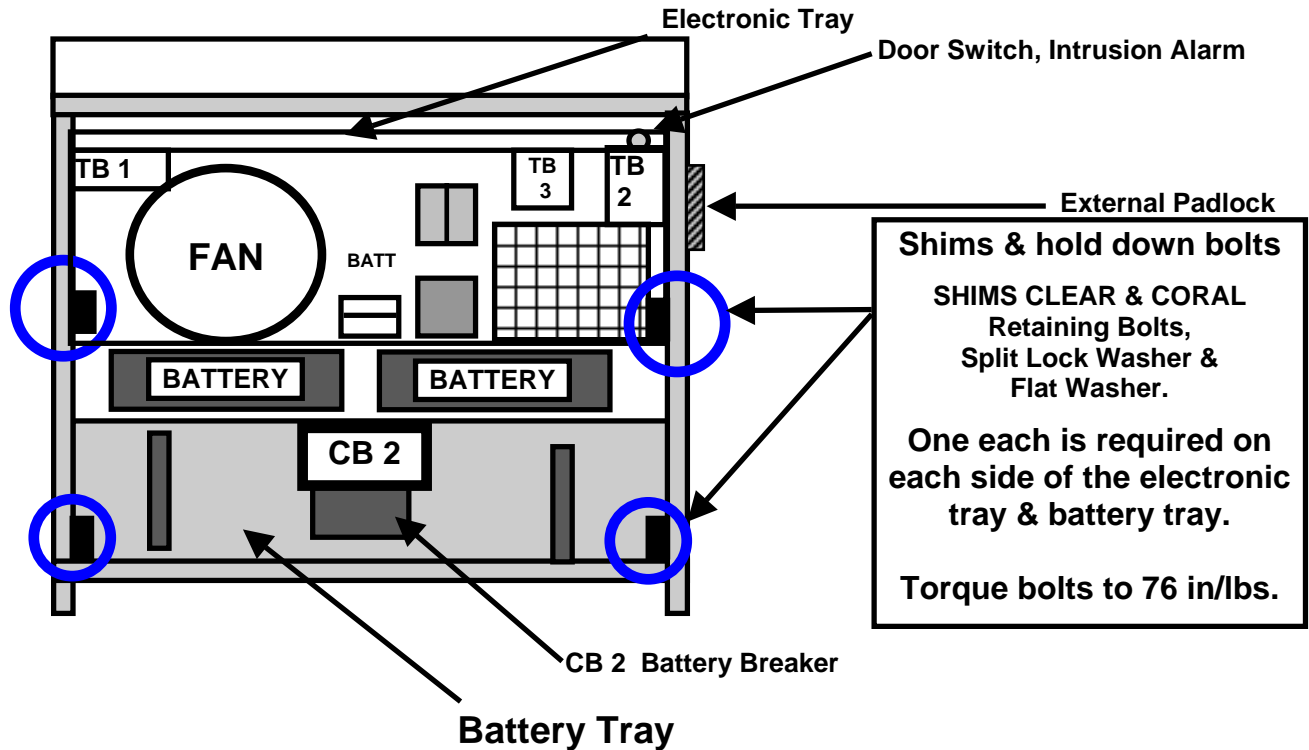

ILLUSTRATION 4-1 :FRONT VIEW OF POWER BACKUP CABINET

### 4-2 Servicing shall start with safety.



- Turn CB 2 to " OFF ", next Turn your AC Input to " OFF " LOCK and tag out of service with digital meter, check all terminals of TB 1 and TB 2 for any voltage.
- With CB 1 and CB 3 turned " OFF ", recheck all terminals of TB 1 and TB 2 and the cabinet to ground should be **Zero** voltages.

### 4-3 Removal of Electronic Tray for Servicing:

- Check each wire has an identification tag before removing.
- Remove the DB-9 plug by unscrewing 2 screws and remove each wire from TB 1 and TB 2 terminals checking tag is correct and readable.

**CAUTION !**

- With electrical tape wrap the ends of all wires.
- Remove the hold down bolt at each side of the electronic tray (see Illustration 4-1).

**CAUTION !**

- Carefully slide the tray out of the cabinet; the electronic tray weights approximately 60 lbs.

### 4-4 Replacing of Electronic Tray:

- Carefully slide the tray into the cabinet use care to guide it in straight.
- Install the hold down bolt at each side of the electronic tray, torque to 76 in/lbs (see illustration 4-1).
- Check the identification tag of each wire before reconnecting.
- Test the PBC operation in the normal mode by following section 3-13 through 3-16.

### 4-5 Battery Tray Removal and Servicing:

**DANGER**

- **CAUTION! ! For HOT SWAPPING use extreme care as main AC line is not turned “ OFF ”or LOCK and tag out of service. Use a digital meter check all terminals of TB 1 and TB 2 for any voltage.**
- Turn CB 2 to “OFF”, unplug the Red and Black connector from the battery jack and on the model 1300 unplug the white connectors for battery heaters.
- Remove the hold down bolts at each side of the battery tray (see Illustration 4-1).
- **ALL BATTERY WORK SHOULD BE PERFORMED ON THE GROUND AS BATTERY TRAY WITH BATTERIES CAN WEIGH OVER 300 LBS, HANDLE CAREFULLY.**
- Carefully slide the Battery tray out of the cabinet.

### 4-6 Replacement of Battery Tray:

- Carefully slide the tray into the cabinet use care to guide it in straight.
- Install the hold down bolts at each side of the battery tray and torque to 76 in/lbs (see Illustration 4-1).
- Install plug the Red and Black connector into the battery jack and on the Model 1300 plug in the white connectors for battery heaters.
- Retest the PBC unit for normal operation following section 3-3 through 3-16.

## 4-7 Replacing A Battery

### **CAUTION !**

- **ALL BATTERY WORK SHOULD BE PERFORMED ON THE GROUND AS BATTERY TRAY WITH BATTERIES CAN WEIGH OVER 300 LBS, HANDLE CAREFULLY.**
- **EYE PROTECTION AND GLOVES SHOULD BE USED.**
- Removal of battery tray is covered in section 4–5.
- Complete all steps of that section first.

## 4-8 Removing a battery from the battery tray:

- Remove the battery straps for battery to be replaced, disconnect the leads from both terminals of battery to be replaced.
- Remove battery gently from the tray and replace with a new battery.
- Reconnect the batteries as shown in Illustration 4-2.
- After the battery connections have been made, check the torque for proper tightness. The recommended torque value is 90 in/lbs.
- Apply a light film of thin grease to each battery connection and cover with black rubber cap.

### **USE CARE IN REINSTALLING THE BATTERY TRAY.**

- The battery tray has a guide on each side to reduce the chance of the drawer tipping when only opened part way.
- Illustration 4-1, shows the battery tray in the cabinet.
- Do not install battery tray until all wiring steps have been completed.
- Retest the PBC unit for normal operation following section 3-14 through 3-16.

## 4-9 Removing Filter Screen

- The Filter screen is located on the cabinet door and can be removed by sliding up to clear guide on each side.
- The Filter screen can be cleaned with hot water and soap.
- The Filter screen shall be dried in sun or blow dry, only clean dry filter screen shall be used.
- Reinstall filter screen by lowering into the guide rails until firmly seated in the bottom.

## Appendix A: SUMMARY OF INDICATORS AND CONTROLS

**AC** - A green LED that is illuminated when utility is present.

**INV** - A green LED is illuminated when the inverter is operating.

**ALM** -A red LED is illuminating if the inverter malfunctions and is no longer supplying power to the output.

**BATT** - Five green LED's and one red LED that illuminates to update status of the battery energy available during a power outage. These lamps do NOT reflect the charged status of the batteries during normal operations. Each of the green LED 'S represents approximately 20 % of the battery reserve power available. As the battery discharge continues, the LED 's will sequentially turn off until the red LED light comes on. This indicates a low battery condition and the PBC will discontinue operation shortly.

**LOAD** - Five green LED 's and one red LED illuminate to indicate the amount of load that the inverter is powering. Each green LED represents 20 % of the full load. As more loads are added, the inverter's LED's will sequentially turn on until the red LED turns on. This indicates an overload condition and the inverter will turn off shortly (15 seconds).

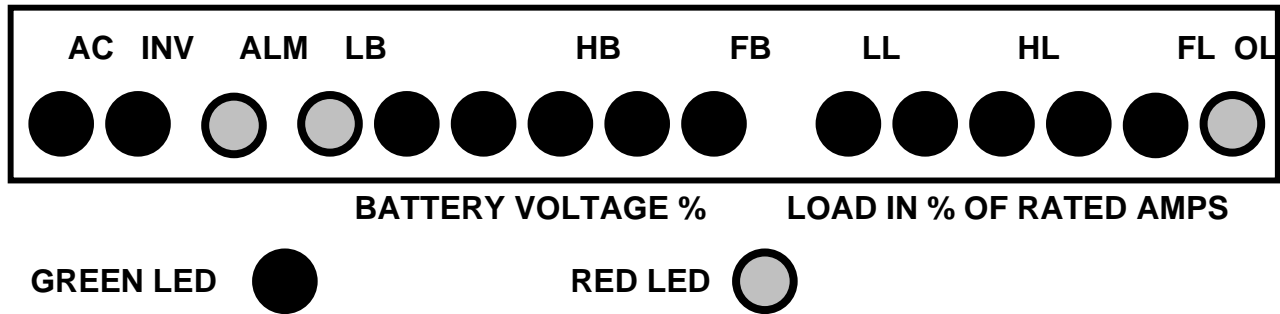

Electronic Tray - Status Panel

## APPENDIX B: INSTALLATION ACCESSORY KIT PAD/POLE MOUNT PARTS LIST

For 120, 208, 240 VAC and 60 Hz -- PBC  
KS LIST 23

DESCRIPTION	QTY	PART NO.
½ FLEXIBLE LIQUID TIGHT CONDUIT ( FOR ALARM CABLE)	14 FT	
½ LIQUID FLEXIBLE METAL SEAL RING	2	T&B 5262
½ LIQUID FLEXIBLE METAL CONDUIT FITTINGS, 90	1	T&B 5352
½ LIQUID FLEXIBLE METAL CONDUIT FITTINGS, STR	1	T&B 5332
1" FLEXIBLE LIQUID TIGHT CONDUIT	14 FT	
1" LIQUIDTIGHT FLEXIBLE METAL CONDUIT SEAL RING	2	T&B 5264
1" LIQUIDTIGHT FLEXIBLE METAL CONDUIT FITTINGS, 90	1	T&B 5354
1" LIQUIDTIGHT FLEXIBLE METAL CONDUIT FITTINGS, STR	1	T&B 5334
AC POWER CABLES 10 AWG	40 FT	THHN-BLK-10-STR
AC POWER CABLES 10 AWG	20 FT	THHN-WHT-10-STR
AC POWER CABLES 10 AWG	20 FT	THHN-GRN-10-STR
6 AWG GREEN GROUND INSULATED CONDUCTOR	6 FT	THHN-GRN-6-STR
M6 x 1.0 x 20 MM LONG, STAINLESS STEEL HEX BOLT	4	
M6 STAINLESS STEEL, LOCKWASHER	4	
M6 STAINLESS STEEL, FLATWASHER	4	
6 AWG TO 2 AWG C-TAP CU	2	
2 HOLE COMPRESSION LUG 6 AWG CU .75 CENTER TO CNTR	2	
1" METAL CLAMP	7	
½" METAL CLAMP	7	
CONNECTOR	1	HEYCO P/N 3214
ALARM CABLE, DB-9, 20 FT	1	

NOTES:

1. INTERCONNECTION HARDWARE BETWEEN THE UPS AND SERVICE ENTRANCE IS NOT INCLUDED IN THIS KIT.
2. THE MAXIMUM DISTANCE BETWEEN THE UPS AND AUXILIARY CABINET SHALL BE 3 FEET.
3. ALL CONDUCTORS SHALL BE COPPER.

## Appendix B: INSTALLATION ACCESSORY KIT PAD/POLE MOUNT PARTS LIST

For 220, 230 VAC and 50 Hz -- PBC  
KS LIST 23A

DESCRIPTION	QTY	PART NO.
½ FLEXIBLE LIQUID TIGHT CONDUIT (FOR ALARM CABLE)	14 FT	
½ LIQUID FLEXIBLE METAL SEAL RING	2	T&B 5262
½ LIQUID FLEXIBLE METAL CONDUIT FITTINGS, 90	1	T&B 5352
½ LIQUID FLEXIBLE METAL CONDUIT FITTINGS, STR	1	T&B 5332
1" FLEXIBLE LIQUID TIGHT CONDUIT	14 FT	
1" LIQUIDTIGHT FLEXIBLE METAL CONDUIT SEAL RING	2	T&B 5264
1" LIQUIDTIGHT FLEXIBLE METAL CONDUIT FITTINGS, 90	1	T&B 5354
1" LIQUIDTIGHT FLEXIBLE METAL CONDUIT FITTINGS, STR	1	T&B 5334
AC POWER CABLES 10 AWG,	20 FT	THHN-BRN-10 -STR
AC POWER CABLES 10 AWG	20 FT	THHN-BLU-10 -STR
AC POWER CABLES 10 AWG	20 FT	THHN-GRN/YL-10 -STR
6 AWG GREEN GROUND INSULATED CONDUCTOR	6 FT	THHN-GRN-6-STR
M6 x 1.0 x 20 MM LONG, STAINLESS STEEL HEX BOLT	4	
M6 STAINLESS STEEL, LOCKWASHER	4	
M6 STAINLESS STEEL, FLATWASHER	4	
6 AWG TO 2 AWG C-TAP CU	2	
2 HOLE COMPRESSION LUG 6 AWG CU .75 CENTER TO CNTR	2	
1" METAL CLAMP	7	
½" METAL CLAMP	7	
CONNECTOR	1	HEYCO P/N 3214
ALARM CABLE, <b>DB 9</b> , 20 FT	1	

NOTES:

1. INTERCONNECTION HARDWARE BETWEEN THE UPS AND SERVICE ENTRANCE IS NOT INCLUDED IN THIS KIT.
2. ALL CONDUCTORS SHALL BE COPPER.

## Appendix C: Battery Maintenance Testing & Specifications

### Battery Specifications:

- Battery Impedance - The battery impedance value is measured @ 25<sup>o</sup>C. This value is for new batteries at full state of charge, on open circuit at a frequency of 30 Hz. Battery type PRC-1250XL impedance is 5.05 milliohms.
- Float Voltage - The specified float voltage “ window ” is 2.27 - 2.30 V.P.C. @ 25<sup>o</sup>C. This value will help in reducing recharge times and keeping the batteries at the highest state of charge.

### Recommended Procedures:

These methods are designed to be used on a battery system installed for a minimum period of 6 month, in a steady state of float condition and not under conditions of high current recharge or discharge.

### Measure Float Voltage:

- When the low battery LED is “ ON ” over 24 hours test system, remove the battery tray plug from the battery jack on the electronic tray, so readings can be taken.
- Measure and record system voltage directly across the battery plug.
- If the battery system is determined to be low voltage system after 24 hours of charging the system voltage will be only 3% low, remove and replace the battery tray.

### Battery Servicing:

- Measure and record a 10% sample of individual battery temperatures at the negative terminal post.
- Identify batteries that are greater than 3<sup>o</sup>C above ambient from the calculated average. If no external causes for higher battery temperatures are noted.
- Check that the filters are clean and Fans are operational.
- If no change is noted, remove and replace the battery tray.

### Visual Inspections:

- Examine batteries for any abnormalities in end wall bulge, post leakage, cover to cells leakage, etc.
- Identify any end wall bulges that exceed 1/2 inch compared to the other batteries in tray.



### Load Testing:

- Load testing shall only be performed as a bench test.
- While on open circuit, place 100 amp load across each battery for a period of 30 seconds.
- Measure and record end of discharge (E.O.D.) voltage at 30 seconds.
- Calculate average and compare results against value of 10.95 for Type PRC 1250XL E.O.D. @ 30 Seconds and 100 amp load.
- If calculated average E.O.D. of group is observed as being normal, identify and replace individual batteries with values that are 10% less than the group average.

### General Equipment Requirements:

- Digital voltmeter- 3 1/2 digit, minimum 0.25% accuracy.
- Load tester (100 amps) with digital voltage readout, minimum 0.25% accuracy.
- Thermometer- thermocouple, contact type, 1 °C accuracy.

### Battery Date Coding:

- The manufacturer stamps the negative terminal post of the battery, with the month and year date code.
- Shelf life is based on normal storage temperature conditions, 66 °F ~ 90 °F and requires recharging every 6 months from the last full charge date.

## WARNING!

- Battery shelf life, when stored under temperature conditions of 66°F ~ 90°F is five(5) months maximum after the ship date.
- Battery must be recharged after this date otherwise they will be damaged.
- The ship date is part of the serial number (see example below).

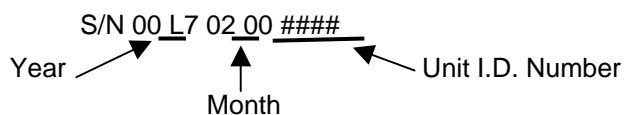

## APPENDIX D: Troubleshooting and Diagnostics

<u>Item</u>	<u>Problem</u>	<u>Cause</u>	<u>Remedy</u>
1	Unit does not start.	1) Input not present.	1) Apply the input power by closing the feeder or wall breaker. 2) Measure and Verify that the input voltage is correct, <b>IF</b> correct turn the input Breaker CB 1, to " ON ", 3) Verify Green LED, " AC ", is " ON ".
		2) Input is not connected properly.	1) Measure and Verify that the input voltage is on the correct terminals of TB 1. 2) See Section 3 - 11, Electronic Tray, input & output wiring for the correct terminals.
2	Unit is very quiet, no noise.	1) Fan or fans are not running.	1) With CB 1 " OFF " check from the front if the fan rotors are free to turn. If jammed replace Electronic Tray. 2) Check if the fan 2 wires are connected. 3) Verify Input power as in Item # 1
3	Unit shuts-off, immediately or within few minutes of input power failure.	1) Battery Tray not connected or Battery Breaker CB 2 " OFF".	1) Verify Black plug, P3, from Battery Tray is connected into Battery Jack, J 3, on Electronic Tray. 2) Verify Battery Breaker, CB 2, on front of Battery Tray is " ON ".
		2) Batteries are discharged.	1) Verify if the Red LED, " Low Battery " Warning is " ON ". Run the unit for over 24 hours to bring the batteries up to proper charge. 2) Verify if the Green LED's Battery Voltage indicators, " HB " to " FB " are " ON ". Run the unit for over 24 hours to bring the batteries up to proper charge.
		3) Batteries are discharged.	1) Verify by disconnecting the Battery Tray Plug, P 3, from Electronic Tray Jack, J 3, & Measure that the DC Voltage at the Plug with CB 2 " ON " is correct. 2) Red to Black terminal shall be 46.0 VDC for 650 watt unit from the Battery Tray. 3) Red to Black terminal shall be 70.0 VDC for 1300 watt unit from the Battery Tray. 4) Measure the Electronic Tray Jack, J 3, has the correct DC voltage with no load. 5) Red to Black terminal shall be 53.0 VDC for 650 watt unit at the Electronic Tray. 6) Red to Black terminal shall be 80.0 VDC for 1300 watt unit at the Electronic Tray. <b>J 3 voltage low then replace the ELECTRONIC TRAY.</b> 7) Run the unit for over 24 hours to bring the batteries up to proper charge.

**APPENDIX D: Troubleshooting & Diagnostics  
Continued**

<b>3</b>		4) Bad Batteries.	<p>1) Verify by measuring the DC Voltage at the Battery Tray Plug, P 3, has changed after 24 hours of charging.</p> <p>2) Red to Black terminal shall be 46.0 VDC for 650 watt unit.</p> <p>3) Red to Black terminal shall be 70.0 VDC for 1300 watt unit.</p> <p><b>REPLACE BATTERY TRAY.</b></p>
<b>4</b>	Red lights on the unit.	1) " ALM " Red light is " ON " .	<p>1) Inverter failure is indicated.</p> <p><b>REPLACE ELECTRONIC TRAY.</b></p>
		2) " LB " Red light is " ON " .	<p>1) Batteries have been discharged to a low battery level condition. Very little or No back-up power is available in case of sustained or future input failures.</p> <p>2) Run the unit for over 24 hours to bring the batteries up to proper charge.</p>
		3) " OL " Red light is " ON " .	<p>1) Unit has exceeded it's full load capacity and is Overload condition.</p> <p><b>Reduce the output load.</b></p> <p>2) Unit has auto shut down mode and will turn " OFF " after 30 seconds.</p>
<b>5</b>	No Output.	1) Output is not connected properly or Output Breaker CB 3 is " OFF " .	<p>1) Turn Output Breaker CB 3 to " ON " .</p> <p>2) Measure and Verify Output voltage is on the correct to terminals of TB 3.</p> <p>3) See Section 3 - 11, Electronic Tray, input &amp; output wiring for the correct terminals.</p>
<b>6</b>	Unstable Output	1) Wrong frequency selection	<p>1) Verify the Red Frequency jumper is on the terminals of TB 3.</p> <p>2) See Section 3 - 10, Electronic Tray wiring Illustration 3 - 4 for the correct terminals.</p>