



# **Technical Publication**

## **NRT & ISO-CARE**

Document No. 6002-033  
Revision "C"

Installation, Operation, and Service Documentation

# OnLine Power

---

Congratulations on selecting one of the fine products from OnLine Power, the Leader in Power Protection Technology. Our wide product offering includes Uninterruptible Power Systems (UPS), Power Conditioners, Automatic Voltage Regulators and Specialty Transformers (e.g. computer-grade, medical-grade). Since our beginnings in 1975, OnLine Power has shipped thousands of these fine products around the world, to discerning customers, for use on sensitive equipment and critical applications. Our customers, both new and long-time, continue to enjoy security and peace of mind as they realize what it means to "Stay On Line with OnLine Power".

One of our goals is to make these manuals both comprehensive and easy to use. This **new-format** User's Manual is the result of ideas and inputs from customers who have taken an active interest in our continued success. We invite constructive feedback on our products and documentation via fax, mail or telephone.

## **HEADQUARTERS**

OnLine Power, Inc  
5701 Smithway Street  
Commerce, CA 90040

## **FACTORY**

OnLine Power, Inc.  
5940 Triumph Street  
Commerce, CA 90040

## **SALES**

Phone (800) 227-8899  
Inside CA (323) 721-5017  
FAX No. (323) 721-3929

## **CUSTOMER SUPPORT**

Phone (800) 797-7782  
(PWR-SRVC)  
FAX No. (323) 721-3929

**OnLine Power, Inc.**  
**Proprietary Reproduction or Distribution forbidden**

**NOTICE: THIS DOCUMENT CONTAINS PROPRIETARY INFORMATION**

This document contains proprietary and confidential information of OnLine Power, Inc. ("OnLine Power"). In consideration of the receipt of this document, the recipient agrees not to copy any of its contents, nor disclose them to or allow them to be used by any person not currently a OnLine Power employee or an employee of the recipient having a need to know, without the express written consent of OnLine Power, and further agrees to surrender this document to OnLine Power when the reason for its receipt has terminated.

## SAFETY

Safety precautions are important when operating or servicing electrical equipment. The following symbols are used extensively throughout this manual. Always heed these precautions since they are essential to the safe operation and servicing of this product.



**THIS DANGER SYMBOL IDENTIFIES A CONDITION OR ACTION WHICH WILL RESULT IN SEVER INJURY OR DEATH TO AN INDIVIDUAL OR SEVER DAMAGE TO EQUIPMENT OR OTHER PROPERTY.**



**This Caution symbol identifies a condition or action which may result in minor injury to an individual or minor damage to the equipment or other property.**

This unit was designed for specific applications. It should **not** be modified and/or used for any application other than for that which it was designed. Optional equipment not described in the sales literature or this manual should not be installed without first checking with the Service department. If you have any questions about this unit's application call the Service department at the number shown on the previous page.

## TABLE OF CONTENTS

<u>SECTION</u>	<u>PAGE</u>
<b>SECTION 1 - INTRODUCTION</b>	<b>1-1</b>
1-1    FEATURES	1-2
<b>SECTION 2 - PREINSTALLATION</b>	<b>2-1</b>
2-1    LOCATION CONSIDERATIONS	2-1
2-2    UNPACKING	2-1
2-3    INSPECTION	2-2
2-4    HANDLING SUGGESTIONS	2-2
<b>SECTION 3 - INSTALLATION</b>	<b>3-1</b>
3-1    INPUT AND OUTPUT POWER CIRCUITS	3-1
3-1-1    Input Power Cable Installation	3-2
3-1-2    Output Power Cable Installation	3-5
<b>SECTION 4 - OPERATION</b>	<b>4-1</b>
<b>SECTION 5 - MAINTENANCE</b>	<b>5-1</b>
5-1    PERIODIC MAINTENANCE	5-1
<b>APPENDIX A - SPECIFICATIONS</b>	<b>A-1</b>

## LIST OF ILLUSTRATIONS

<u>ILLUSTRATION</u>	<u>PAGE</u>
1-1    ISO-CARE & NRT	1-1
1-2    ISO-CARE FEATURES	1-2
1-3    NRT FEATURES	1-3
1-4    ISO-CARE FUNCTIONAL BLOCK DIAGRAM	1-4
1-5    NRT FUNCTIONAL BLOCK DIAGRAM	1-4
2-1    ISO-CARE DIMENSIONS	2-3
2-2    NRT DIMENSIONS	2-4
3-1    ISO-CARE INPUT AND OUTPUT TERMINAL CONNECTION (15-125 KVA)	3-3
3-2    ISO-CARE INPUT AND OUTPUT TERMINAL CONNECTION (150-500 KVA)	3-3
3-3    NRT INPUT AND OUTPUT TERMINAL CONNECTION (15-125 KVA)	3-4

## SECTION 1 - INTRODUCTION

The Iso-Care and NRT (Noise Reduction Transformer) are three-phase, delta to wye isolation transformers designed for isolation with optional distribution of AC power.

The Iso-Care and NRT can accommodate input voltages 208 or 480 VAC +5% and -10%, and output voltages 208Y/120 or 480Y/277. The input frequency range of the Iso-Care is 50 to 60 Hz. The NRT is designed for 60 Hz only.

The model number along with the input and output voltages are provided on the label plate located on the front of the unit.

All components used are of the highest quality and specifically selected to achieve the highest level of performance. The Iso-Care and NRT transformers are UL listed and the units are certified by UL Laboratory Inc. in accordance with IEC Pub 601-1. The Iso-Care and NRT conforms to National Electric Code (NEC) and Occupational Safety and Health Act (OSHA) standards.

The purpose of this manual is to familiarize the user with the features of the Iso-Care and NRT and to provide installation, operation and maintenance information.

The Iso-Care and NRT are shown in Illustration 1-1.

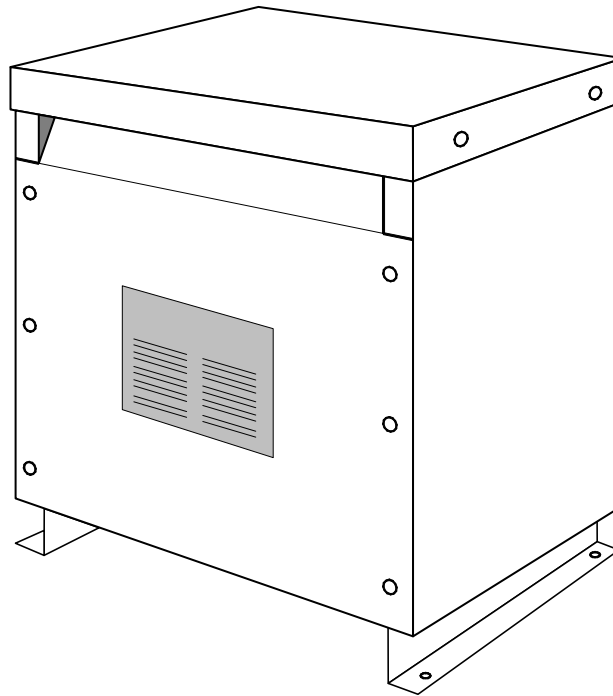

**ISO-CARE AND NRT**  
ILLUSTRATION 1-1

# OnLine Power

---

## 1-1 ISO-CARE FEATURES

The Iso-Care provides the following features:

- Ground lug
- Seismic mounting holes
- Transformer tap connections accessible from front of unit
- NEMA indoor cabinet
- Three phase, single-shielded, computer grade, isolation transformer

See Illustration 1-2 for the location of features described in this section.

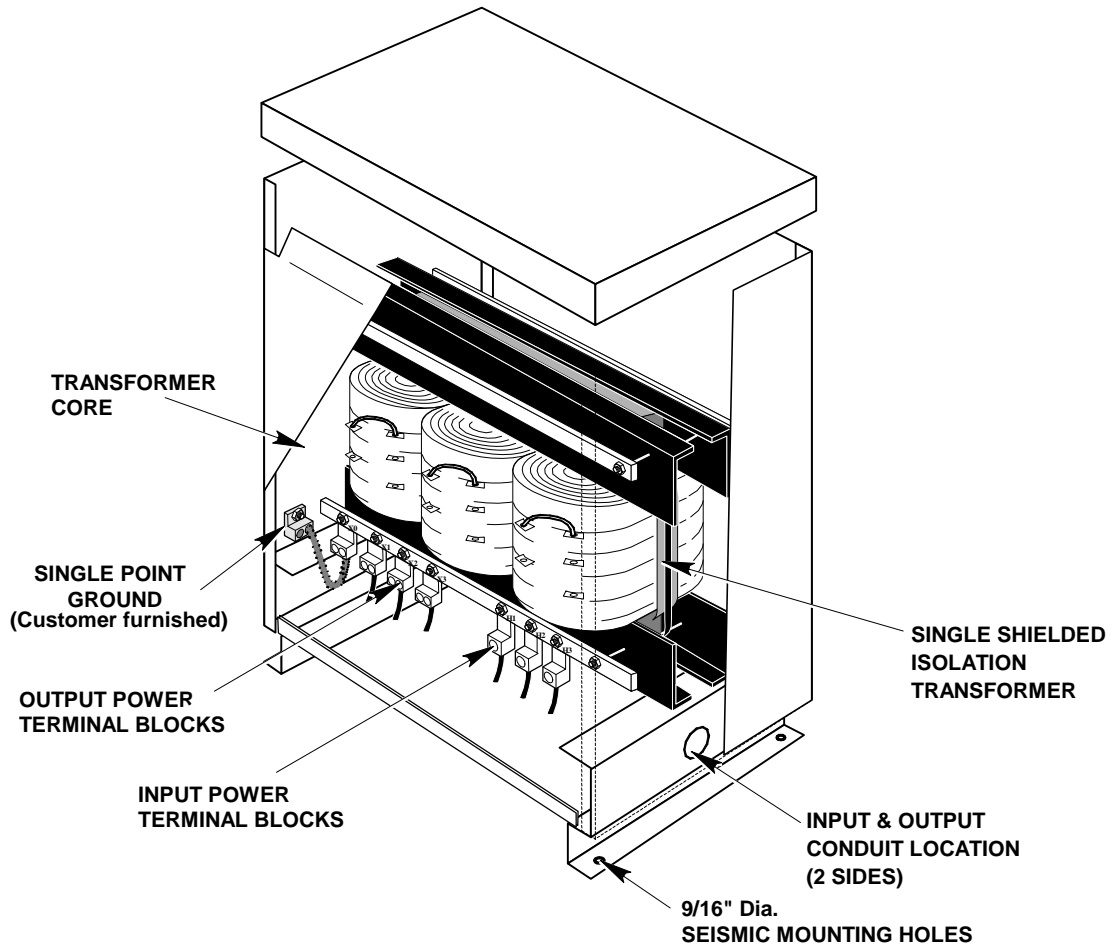

ISO-CARE FEATURES (15-125 KVA)  
ILLUSTRATION 1-2

# OnLine Power

---

## 1-2 NRT FEATURES

The NRT (Noise Reduction Transformer) provides the following features:

- Three-phase, double-shielded, computer grade, isolation transformer
- Input and output terminals
- Transformer tap connections accessible from front of unit
- Surge suppression Failure Indicators (optional)
- Input and output filters (optional)

See Illustration 1-3 for the location of features described in this section.

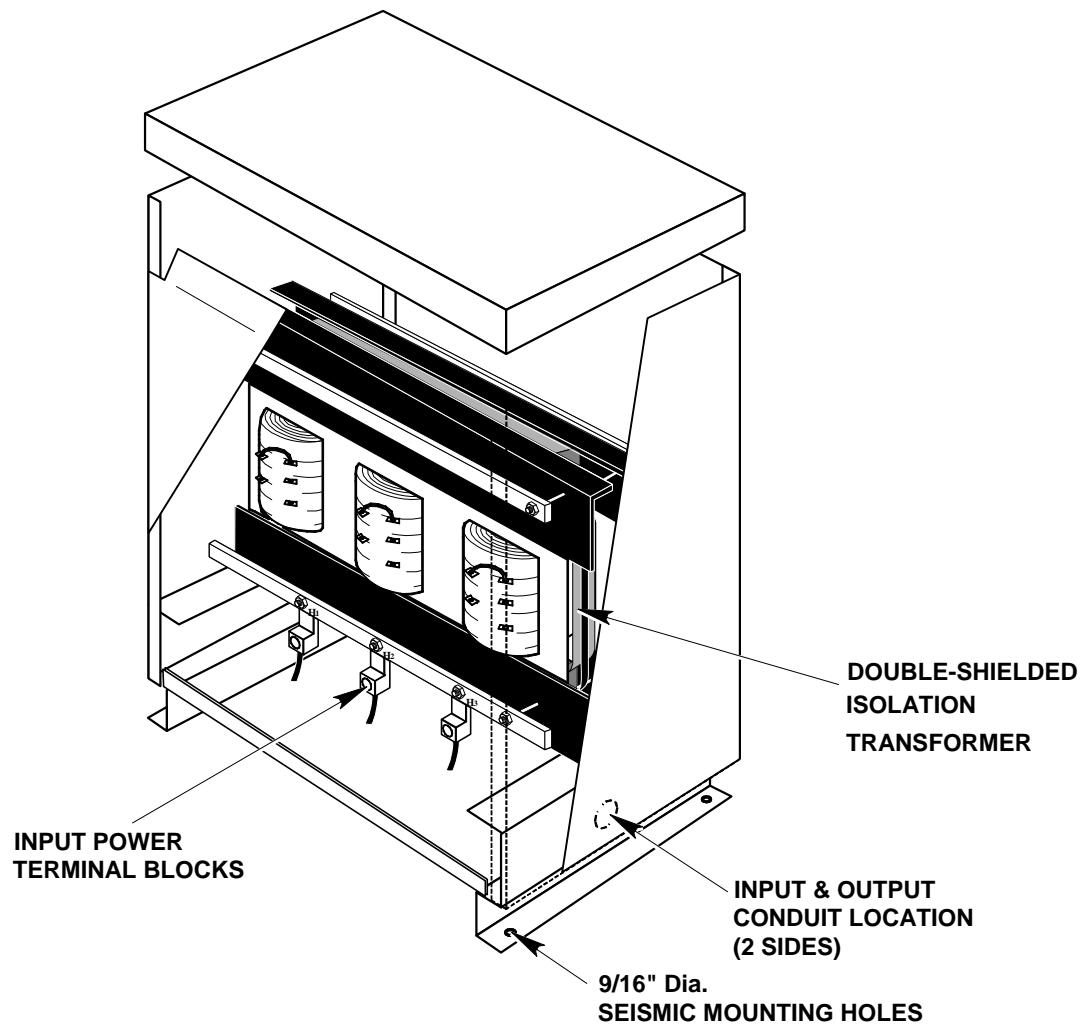

NRT FEATURES  
ILLUSTRATION 1-3



# OnLine Power

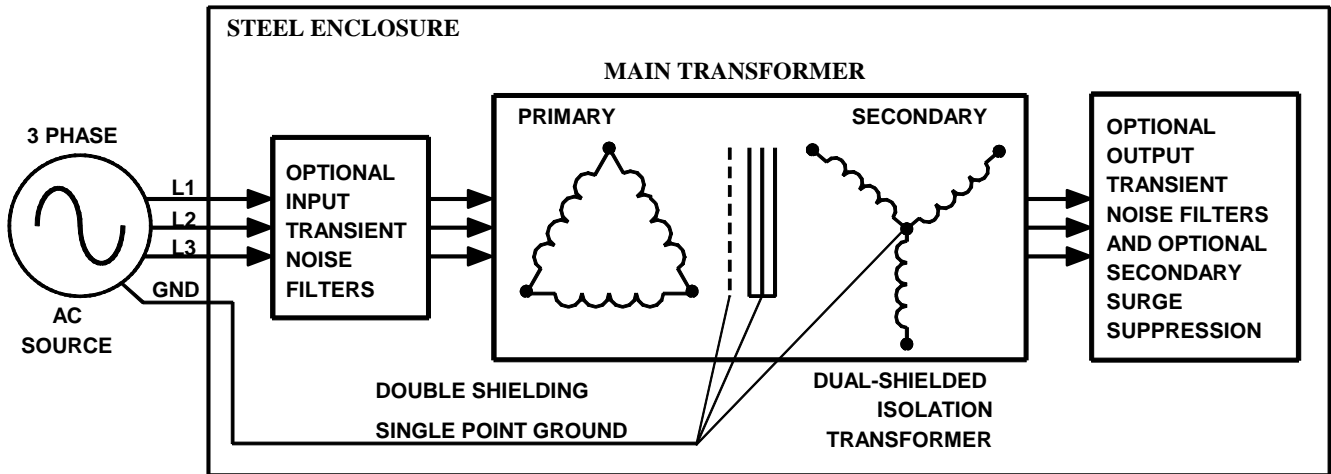

ISO-CARE FUNCTIONAL BLOCK DIAGRAM  
ILLUSTRATION 1-4

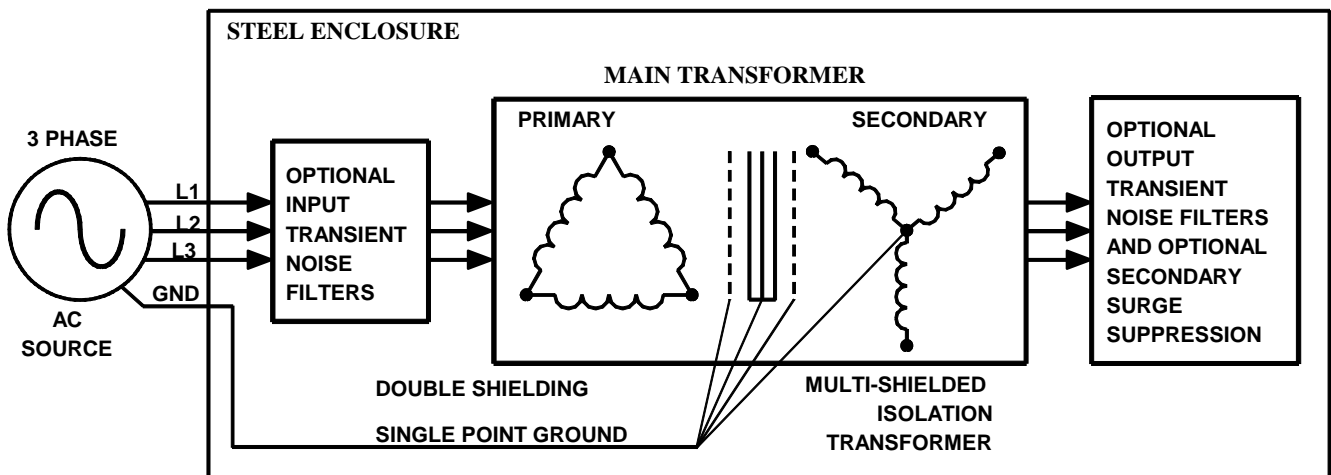

NRT FUNCTIONAL BLOCK DIAGRAM  
ILLUSTRATION 1-5



# OnLine Power

---

## 2-3 INSPECTION

Perform the following Inspection procedure of the Iso-Care or NRT to check for obvious damage or safety hazards that may have occurred during shipping or handling of the unit. All units must be inspected when received and again prior to use. Any damage must be reported immediately to ONLINE POWER, INC. or an authorized representative. Freight damage claims should be initiated with the carrier.



**Do not connect unit to building power until the following procedure has been completed.**

1. Inspect all external surfaces (panels, covers, etc.) for abrasions, indentations, or other obvious damage.
2. File a claim with shipping agency for any damage caused by shipping.
3. Forward a copy of damage claim to ONLINE POWER, INC. at the following address:

### **ONLINE POWER, INC.**

Attn: Customer Service Dept  
5701 Smithway Street  
City of Commerce, CA 90040  
**(800) PWR-SRVC** (797-7782)

## 2-4 HANDLING SUGGESTIONS

Plan route to installation site to ensure that all passages are large enough and that floors can support weight of unit. That is, are all floors, doorways, ramps, elevators, etc. adequate? Are there any non-negotiable corners?

# OnLine Power

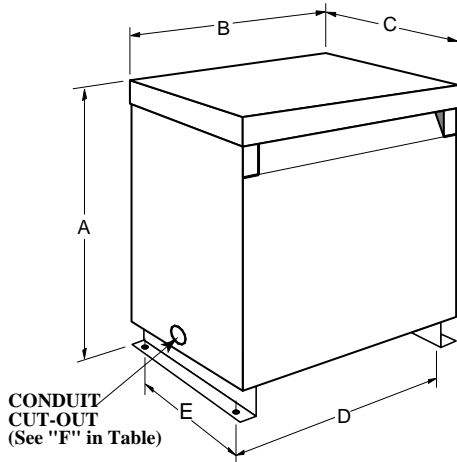

Units	A	B	C	D	E	F
15 kVA	28"	21"	14"	18"	10"	3" Dia
30, 50 kVA	32"	26.5"	17"	23"	12"	3" Dia
75-125 kVA	40.5"	31.5"	22"	28"	17"	4" Dia
150-300 kVA	51.5"	40.5"	26.5"	37"	20.5"	5" Dia
400-500 kVA	66"	50.0"	32"	46.5"	24"	5" Dia

**ISO-CARE DIMENSIONS**  
ILLUSTRATION 2-1

TABLE 2-1  
**ISO-CARE SPECIFICATION**

kVA	INPUT VOLTAGE	MODEL NUMBER		WEIGHTS (LBS)	BTUs/HR	CABINET SIZES (H x W x D)
		208Y/120 OUT	480Y/277			
15	208	IC015B0500I3	IC015B0900I3	300	2040	28" x 21" x 14"
	480	IC015H0500I3	IC015H0900I3			
30	208	IC030B0500I3	IC030B0900I3	420	4080	32" x 26.5" x 17"
	480	IC030H0500I3	IC030H0900I3			
50	208	IC050B0500I3	IC050B0900I3	510	6800	
	480	IC050H0500I3	IC050H0900I3			
75	208	IC075B0500I3	IC075B0900I3	670	10200	40.5" x 31.5" x 21.75"
	480	IC075H0500I3	IC075H0900I3			
100	208	IC100B0500I3	IC100B0900I3	800	13600	
	480	IC100H0500I3	IC100H0900I3			
125	208	IC125B0500I3	IC125B0900I3	890	17000	
	480	IC125H0500I3	IC125H0900I3			
150	208	IC150B0500I3	IC150B0900I3	970	20400	51.5" x 40.5" x 26.5"
	480	IC150H0500I3	IC150H0900I3			
175	208	IC175B0500I3	IC175B0900I3	1150	23800	
	480	IC175H0500I3	IC175H0900I3			
200	208	IC200B0500I3	IC200B0900I3	1300	27200	
	480	IC200H0500I3	IC200H0900I3			
225	208	IC225B0500I3	IC225B0900I3	1400	30600	
	480	IC225H0500I3	IC225H0900I3			
250	208	IC250B0500I3	IC250B0900I3	1500	34000	
	480	IC250H0500I3	IC250H0900I3			
300	208	IC300B0500I3	IC300B0900I3	1700	40800	
	480	IC300H0500I3	IC300H0900I3			
400	208	IC400B0500I3	IC400B0900I3	2350	54400	66" x 50.5" x 32"
	480	IC400H0500I3	IC400H0900I3			
500	208	IC500B0500I3	IC500B0900I3	2550	68000	66" x 50.5" x 32"
	480	IC500H0500I3	IC500H0900I3			

# OnLine Power

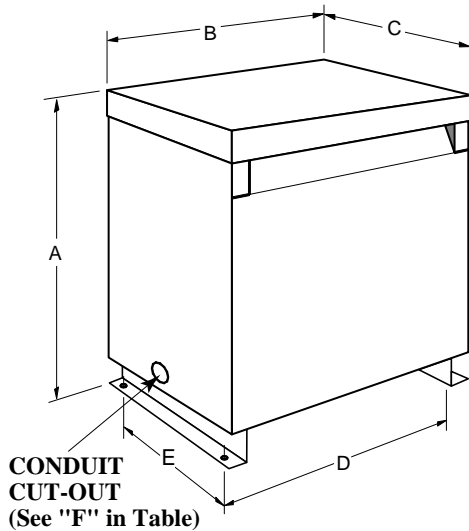

Units	A	B	C	D	E	F
15, 30, 50 kVA	40.5"	31.5"	22"	28"	17"	4" Dia
75, 100, 125, AND 150 kVA	51.5"	40.5"	26.5"	37"	20.5"	5" Dia

**NRT DIMENSIONS**  
ILLUSTRATION 2-2

TABLE 2-2  
**NRT SPECIFICATION**

kVA	INPUT VOLTAGE	MODEL NUMBER		WEIGHTS (LBS)	BTUs/HR	CABINET SIZES (H x W x D)
		208Y/120 OUT	480Y/277			
15	208	NR015B0500I3	NR015B0900I3	400	2040	40.5" x 31.5" x 22"
	480	NR015H0500I3	NR015H0900I3			
30	208	NR030B0500I3	NR030B0900I3	460	4080	
	480	NR030H0500I3	NR030H0900I3			
50	208	NR050B0500I3	NR050B0900I3	550	6800	
	480	NR050H0500I3	NR050H0900I3			
75	208	NR075B0500I3	NR075B0900I3	710	10200	51.5" x 40.5" x 26.5"
	480	NR075H0500I3	NR075H0900I3			
100	208	NR100B0500I3	NR100B0900I3	850	13600	
	480	NR100H0500I3	NR100H0900I3			
125	208	NR125B0500I3	NR125B0900I3	940	17000	
	480	NR125H0500I3	NR125H0900I3			
150	208	NR150B0500I3	NR150B0900I3	1050	20400	
	480	NR150H0500I3	NR150H0900I3			

## SECTION 3 - INSTALLATION

The following instructions cover general requirements for changing the input voltage configuration and for installing the primary input power and secondary output power circuits for the Iso-Care and NRT transformers.



**VERIFY THAT INCOMING HIGH VOLTAGE CIRCUITS ARE DE-ENERGIZED BEFORE CHANGING VOLTAGE CONFIGURATION, INSTALLING CABLES OR MAKING ANY CONNECTIONS.**

### 3-1 INPUT AND OUTPUT POWER CIRCUITS

The customer-furnished primary input power circuit provides power from the building source to the Iso-Care or NRT. The customer-furnished secondary output power circuit provides power from the Iso-Care or NRT to the customer's equipment.

The Iso-Care and NRT have one(1) conduit cutout on the left and right side of the unit's frame to accommodate the input and output power cables. Refer to Illustration 2-1 or 2-2.

The front and rear panels should be removed by unbolting six fasteners located on sides of the front and rear panels.

If cables are crossed or wires are likely to touch, insulating sleeves or their equivalent must be used to prevent wires from touching.



**POTENTIAL ELECTRICAL HAZARDS TO HUMAN LIFE EXIST WITHIN THIS EQUIPMENT WHEN ENERGIZED. DISCONNECT INPUT POWER TO UNIT BEFORE OPENING ENCLOSURE OR TOUCHING INTERNAL PARTS.**



**Input power connection and required branch circuit breaker should be installed by a licensed electrical contractor in accordance with local codes. Primary and secondary power circuit conductors must not touch each other. If conductors touch, use insulating sleeves.**

# OnLine Power

---

## 3-1-1 Input Power Cable Installation

The primary input power circuit should be dedicated exclusively to providing power to the Iso-Care or NRT unit. This circuit must include three phase conductors and an insulated ground conductor. Size the primary input cable to suit the unit's kVA rating, the input voltage and the overall length of the cable. The input cable size and installation must be in accordance with the National Electrical Code (NEC) and applicable local codes. A parity sized ground, with respect to the primary input conductors is recommended.

**NOTE:** The grounding conductor is to be grounded to earth at the service equipment or other acceptable true building ground such as the building frame in the case of a high-rise steel frame structure.

The primary input power circuit should be installed by a licensed electrician.

Install primary input power cable as follows:

1. Turn facility circuit breaker to OFF, lock and tagout in accordance with OSHA Lockout/Tagout requirements.
2. Remove front panel by unbolting six screws at corners and at left and right sides of panel.
3. The Iso-Care and NRT have conduit cutouts on the left and right sides of the unit's frame to accommodate the input and output power cables.
4. Cut proper size hole in side panel to match input conduit.
5. Insert cable/conduit through hole (cutout) in panel and into hole in frame. Secure with appropriate fitting.
6. Prepare cable ends by removing 3/4 inch of insulation from each input power cable conductor.
7. Identify each phase conductor according to phase A, B, C (H1, H2, H3). Identify ground conductor.
8. Route power conductors to input lugs. (See Illustration 1-2 or 1-3. Also see Illustration 3-1, 3-2, or 3-3). Torque to 25 in-lb (29 NM).
9. Connect grounding conductor as follows: (See Illustration 1-2 or 1-3) Torque to 25 in-lb (29 NM).

# OnLine Power

---

## 3-1-1 Input Power Cable Installation (continued)

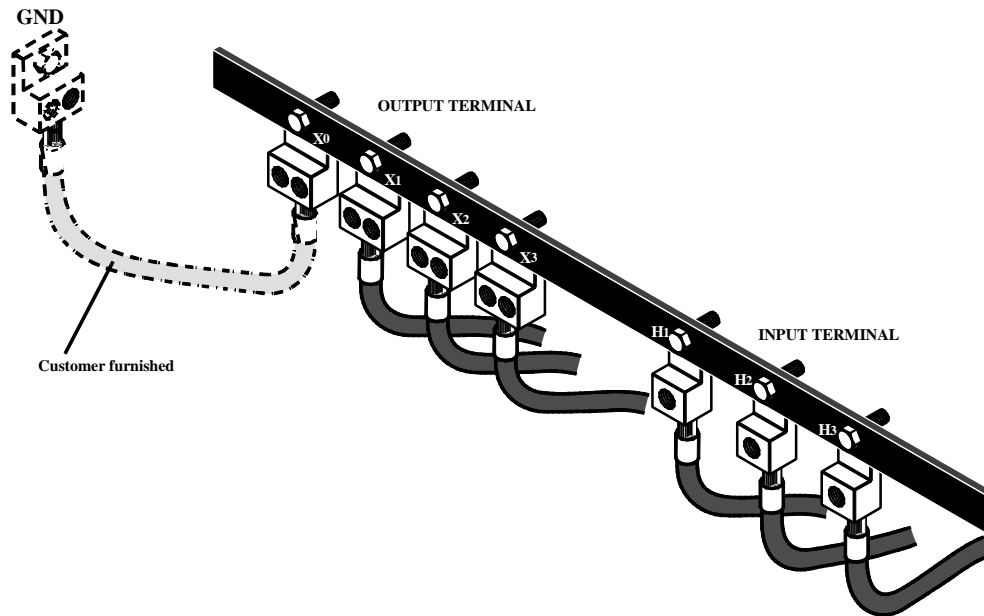

ISO-CARE TRANSFORMER INPUT & OUTPUT TERMINAL CONNECTION (15-125 KVA)  
ILLUSTRATION 3-1

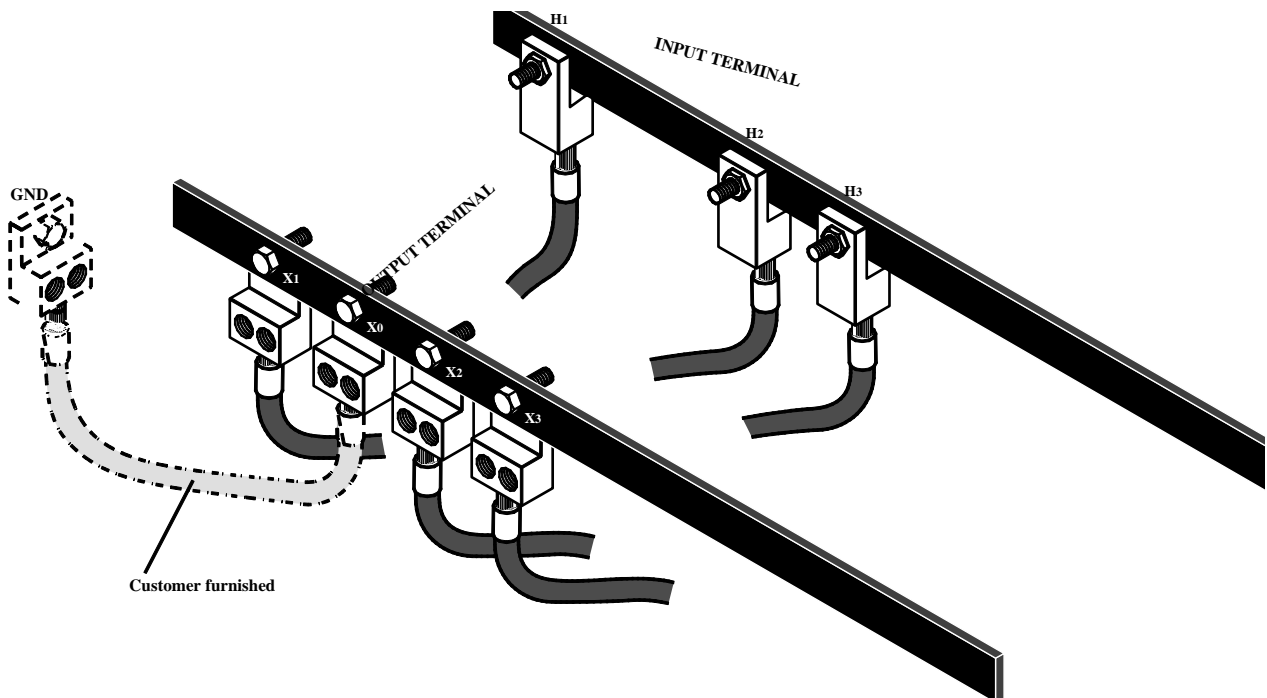

ISO- CARE TRANSFORMER INPUT & OUTPUT TERMINAL CONNECTION (150-500 KVA)  
ILLUSTRATION 3-2



# OnLine Power

---

## 3-1-1 Input Power Cable Installation (continued)

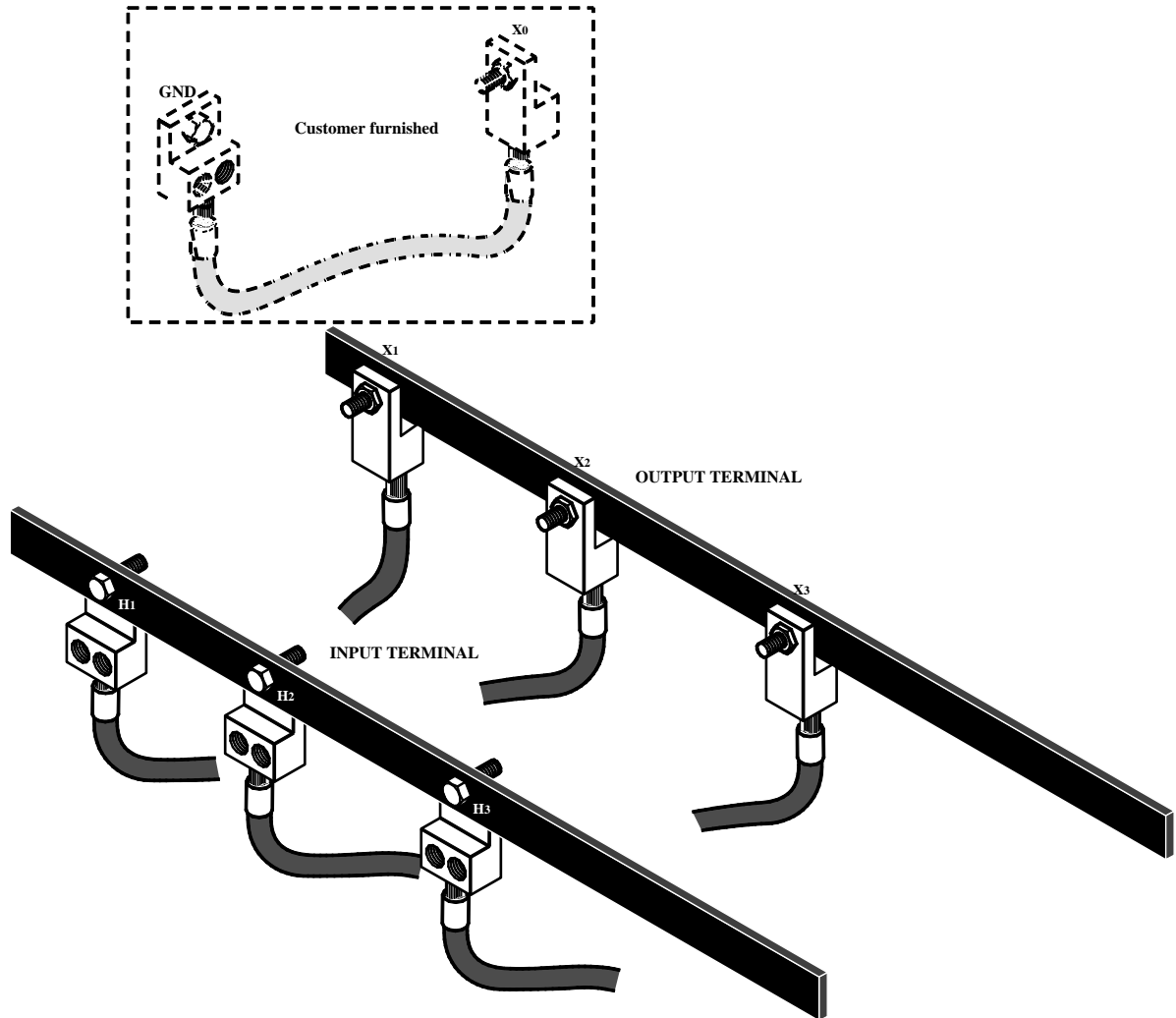

NRT INPUT & OUTPUT TERMINAL CONNECTION  
ILLUSTRATION 3-3

# OnLine Power

---

## 3-1-2 Output Power Cable Installation



Output power cable should be installed by a licensed electrical contractor or certified Facilities Engineer in accordance with local codes.



**VERIFY THAT INCOMING HIGH VOLTAGE CIRCUITS ARE DE-ENERGIZED BEFORE CONTINUING WITH THIS PROCEDURE.**

1. Turn facility circuit breaker to OFF, lock and tagout in accordance with OSHA Lockout/Tagout requirements.
2. Remove front panel by unbolting six screws at corners and at left and right sides of each panel.
3. Cut proper size hole in side panel to match output conduit.
4. Insert cable/conduit through hole in panel and into hole in frame. Secure cable/conduit with appropriate fitting.
5. Remove 3/4 inch of insulation from each conductor.
6. Identify each conductor according to phase, neutral or ground.
7. Connect conductors as follows:
  - a. Identify each phase conductor according to phase A, B, C (X1, X2, X3)
  - b. Route phase conductors to output lugs (see Illustrations 1-2 or 1-3. Also see Illustration 3-1, 3-2, or 3-3). Torque to 25 in-lb (29 NM).
  - c. Route neutral conductor to X0 lug. Torque to 25 in-lb (29 NM).
  - d. Route grounding conductor to ground lug.
  - e. Insert prepared end of grounding conductor into ground lug and torque to 25 in-lb (29 NM).

# OnLine Power

---

## SECTION 4 - OPERATION

The Iso-Care and NRT are designed for continuous unattended use; however, the unit can be switched ON and OFF as required.

### **Switch the unit ON as follows:**

1. Verify that connected load is OFF.
2. Visually inspect input cable to verify that unit is properly connected to facility power source. Refer to 3-1-1 and 3-1-2.
3. Turn facility circuit breaker ON.
4. Using a volt meter, verify that the input voltage to be supplied to the unit matches the input voltage stated on the unit's name plate. If the voltages do not match, contact On-Line Power, Customer Support, for assistance. The toll-free number is (800) PWR-SRVC. Do NOT apply voltage to the unit if there is a voltage mis-match.
5. Turn ON connected load.

### **Switch the unit OFF as follows:**

1. Turn OFF connected load.
2. Turn OFF facility circuit Bbreaker.

## SECTION 5 - MAINTENANCE

### 5-1 PERIODIC MAINTENANCE

#### When to Perform

Perform Periodic Maintenance (PM) every sixth month after installation according to following procedure.

#### How to Perform

Periodic Maintenance must be accomplished with top cover, front and rear panels removed.

Perform a complete cleaning and inspection as described in the following procedure.

#### Tools Required

- Common electrician tools
- Vacuum cleaner with hose

#### PM Procedure



**DISCONNECT INPUT POWER TO ISO-CARE OR NRT BEFORE PERFORMING PERIODIC MAINTENANCE.**

1. Turn OFF all the units or equipments connected to the Iso-Care or NRT.
2. Turn facility circuit breaker OFF, lock and tagout in accordance with OSHA Lockout/Tagout requirements.
3. Remove top cover by unbolting two screws on each side of cover.
4. Remove front and rear panels by unbolting six screws at corners and at left and right sides of each panel.
5. Clean dust from all interior surfaces of unit.

# OnLine Power

---

## **5-1 PERIODIC MAINTENANCE (continued)**

6. Verify proper phasing of input and output power connections.
7. Inspect input and output power cables and all interior wiring for damage due to abrasion, over-heating or other cause.
8. Verify that all power connections are torqued to 25 in-lb (29 NM).
9. Replace front and rear panels.
10. Replace top cover.
11. Turn facility circuit breaker to ON.

# OnLine Power

---

TABLE A-1  
ISO-CARE SPECIFICATIONS

SIZE	15, 30, 50, 75, 100, 125, 150, 175, 200, 225, 250, 300, 400, and 500 kVA
NOMINAL INPUT VOLTAGES	208 OR 480 +5%, -10% @ 2.5% Increments
OUTPUT VOLTAGE	208Y/120, or 480/277
FREQUENCY (Hz)	50 to 60 Hz +/- 5%
TRANSFORMER TYPE	3 Phase Computer Grade, Dual-Shielded, Isolation Transformer
NOISE ATTENUATION: COMMON-MODE NORMAL MODE	-120 dB 20 dB/Decade
LOAD POWER FACTOR	.3 Leading or Lagging to unity
AUDIBLE NOISE	<35 dB. Measured on Response Curve "A"
EFFICIENCY	96.7 at Full Loads 98.5% at Light Loads
OVERALL INRUSH RATING	200% of full load for 30 minutes 1000% of full load for 1 cycle
OUTPUT IMPEDANCE	3 to 5%
OPERATING TEMPERATURE	32° F (0° C) to 104° F (40° C)
STORAGE TEMPERATURE F (C)	5° F (-15° C) to 122° F (50° C)
OPERATING HUMIDITY	5-95% Non-Condensing

TABLE A-2  
NRT SPECIFICATIONS

SIZE	15, 30, 50, 75, 100, 125, and 150 kVA
NOMINAL INPUT VOLTAGES	208 OR 480 VAC
OUTPUT VOLTAGE	208Y/120, or 480/277 VAC
FREQUENCY (Hz)	60 Hz +/- 5%
TRANSFORMER TYPE	3 Phase Computer Grade, Multi-Shielded, Isolation Transformer
NOISE ATTENUATION: COMMON-MODE NORMAL MODE	-126 dB -20 dB/Decade
LOAD POWER FACTOR	.3 Leading to .3 Lagging
AUDIBLE NOISE	<35 dB. Measured on Response Curve "A"
EFFICIENCY	96% at Full Loads 98.5% at Light Loads
OVERALL INRUSH RATING	200% of full load for 30 min 100% of full load for 1 cycle
STORAGE TEMPERATURE F° (C°)	5° F (-15° C) to 122° F (50° C)
OPERATING TEMPERATURE	32° F (0° C) to 104° F (40° C)
OPERATING HUMIDITY	5-95% without Condensation