



Three-Phase Power Wave Elevate Elevator Battery Backup System Installation and Operation Manual

**Power Wave Elevate, Standard Units 24 – 240KW
30-300KVA**

Sales

Email: sales@onlinepower.com

Sales: (800) 227-8899

Service

Email: Service@800pwrsrv.com

Service: (800-797-7782)

Document No.: 120-EL-MAN, REV. A

Notice of Rights

This document contains proprietary and confidential information of OnLine Power. No part of this manual may be reproduced, copied, translated or transmitted, in any form or by any means, without the prior written permission of the manufacturer.

In consideration of the receipt of this document, the recipient agrees not to copy any of its contents, nor to disclose them to or allow them to be used by any person not currently company employee or an employee of the recipient having a need to know, without the express written consent of the company, and further agrees to surrender this document to company when the reason for its receipt has terminated.

Notice of Liability

Information provided in this manual is intended to be accurate and reliable. However, manufacturer assumes no responsibility for its use, nor for any infringement of rights of third parties which may result from its use. **THIS DOCUMENT IS PROVIDED "AS IS" AND ANY EXPRESS OR IMPLIED WARRANTIES, INCLUDING, BUT NOT LIMITED TO, THE IMPLIED WARRANTIES OF MERCHANTABILITY AND FITNESS FOR A PARTICULAR PURPOSE ARE DISCLAIMED. IN NO EVENT SHALL ABOVE COMPANY BE LIABLE FOR ANY DIRECT, INDIRECT, INCIDENTAL, SPECIAL, EXEMPLARY, OR CONSEQUENTIAL DAMAGES (INCLUDING, BUT NOT LIMITED TO, PROCUREMENT OF SUBSTITUTE GOODS OR SERVICES; LOSS OF USE, DATA, OR PROFITS; OR BUSINESS INTERRUPTION) HOWEVER CAUSED AND ON ANY THEORY OF LIABILITY, WHETHER IN CONTRACT, STRICT LIABILITY, OR TORT (INCLUDING NEGLIGENCE OR OTHERWISE) ARISING IN ANY WAY OUT OF THE USE OF THIS DOCUMENT, EVEN IF ADVISED OF THE POSSIBILITY OF SUCH DAMAGE.**

Trademarks

All trademarks and registered trademarks are the property of their respective owners.

Three-Phase Power Wave Elevate

Elevator Battery Backup System

Installation and Operation Manual

Document No.: 120-EL-MAN, REV. A

2/18/2025

Table of Contents

Table of Contents	3
Introduction.....	5
Scope and Audience.....	5
Safety and Warnings	5
Warranty Registration and Warranty Certificate Request	6
Service	6
Chapter 1. Safety	7
Chapter 2. Overview	11
2.1 Product Description	12
2.2 Product Main Features.....	15
Chapter 3. Hardware Overview	21
3.1 Key Components	22
3.2 Functional Description	25
3.3 General Topology	27
3.4 Modes of Operation	29
3.5 System highlighted features.....	31
Chapter 4. Installation	34
4.1 Delivery Space Requirements.....	35
4.2 Site Considerations.....	43
4.3 Delivery and Handling.....	46
Chapter 5. Operation	52
5.1 Starting the Unit for the First Time	53
5.2 Shut-down Procedure	55
5.3 From Inverter to Maintenance Bypass Procedure	56
5.4 From Maintenance Bypass to Inverter Procedure	56
5.5 LCD Display.....	57
5.6 Front Panel.....	67
Chapter 6. Maintenance	73
6.1 Safety Precautions.....	74
6.2 Preventative Maintenance	75

6.3 FRU Replacement	79
6.4 Customer Service and Support	81
Chapter 7. Troubleshooting	83
7.1 Troubleshooting Guide.....	84
APPENDIX A - Battery Connections.....	88
APPENDIX B - Options	94
B.1 Dry Contacts	94
B.2 Sub-Feed UL489 Breaker for Elevator.....	95
B.3 Sub-Feed UL489 Breaker for Emergency Lightings.....	95
B.4 Regen Manager (for Regen Elevators):	95
B.5 Battery to Utility Time Delay (120 sec or 60 sec)	96
B.6 Main Input CB custom KAIC	96
B.7 Main Output CB custom KAIC	96
B.5.2 External Shutdown.....	97
B.5.3 DB9 Connection.....	97
B.5.4 Local Monitoring via PC with RS-485 or RS232.....	97
B.5.5 Simple Network Management Protocol	97
B.8 Seismic Mounting Bracket	98
B.9 Battery String Monitoring (Wireless).	98
B.10 Battery (Individual) Monitoring (Wireless)	98
B.11 Battery Thermal Runaway Control.....	98
B.12 Battery Breaker Alarm	98
B.13 Battery Thermal Runaway Control with dry contact for remote monitoring.....	99
B.14 Battery Cabinet exhaust fan only without alarm and indicator	99
B.15 Battery Cabinet exhaust fan with local alarm, indicator and dry contact for remote monitoring.....	99
B.16 Delta Input/Output systems	99
B.17 Battery Exerciser (setting)	100
B.17.1 Setting the battery test schedule.....	106
B.18 Seismic Series.....	111
APPENDIX C - Specifications	113

Introduction

Congratulations on selecting one of the fine products from the leader in power-protection technology. Our wide product offering includes Uninterruptible Power Systems (UPS), power conditioners, automatic voltage regulators, and specialty transformers (e.g., computer-grade, medical-grade). Since 1972, the manufacturer has shipped many of these fine products to discerning customers around the world for use on sensitive equipment and critical applications.







The Power Wave Elevate UL924 UPS is a self-contained unit that provides backup power for the Elevator, and fluorescent and incandescent lighting sources such as overhead fixtures and exit signs. During power outage, the UPS provides 120 minutes for Elevator Back up and min.90 minutes of lighting power to ensure a safe building evacuation. On line pulse-width modulation (PWM) handles the switchover from utility power to battery power automatically, without interruption or manual intervention. Convection cooling allows the inverter to operate virtually silently.

Scope and Audience

This guide is intended to be used as a reference for users responsible for installing, operating, and maintaining this equipment.

Safety and Warnings

This guide uses the following symbols to draw your attention to certain information.

	Note	Notes emphasize or supplement important points of the main text.
	Tip	Tips provide helpful information, guidelines, or suggestions for performing tasks more effectively.
	Caution	Cautions indicate that failure to take a specified action could result in damage to the hardware.
	DANGER	The Danger symbol warns users of possible injury or death if instructions are not followed.
	Electrostatic Sensitive	This symbol warns users that the equipment is sensitive to electrostatic discharge (ESD) and could be damaged if users do not take appropriate precautions such as using a grounded wrist strap when touching or handling the equipment.
	Electrostatic sensitive	Components are Electrostatic Discharge Susceptible (ESDS) Use a grounded ESD wrist strap.

Warranty Registration and Warranty Certificate Request

Web: www.800pwrsrv.com under download tab

Service

If you require assistance, fill out a Service Report Form at www.800pwrsrv.com, email us at service@800pwrsrv.com, or call our 24-hour toll free hot line (800-797-7782). Please have the unit's SERIAL NO. from the Start-Up label located on the top right front door for speed assistance.

Chapter 1. Safety

This chapter contains safety precautions to observe when operating or servicing electrical equipment. The symbols shown are used extensively throughout this manual. Always heed these precautions because they are essential to the safe operation and service of this product.



DANGER: Only factory-trained or authorized personnel should attempt to install or repair the unit or its battery system. Improper installation has proven to be the single most significant cause of start-up problems. High AC and DC electrical voltages are present throughout the unit(s) and incorrect installation, or servicing could result in electrocution, fire, explosion, or equipment failure.



DANGER: Read this manual in its entirety before performing the installation, start-up, operation, or maintenance of the UPS unit or battery systems. Failure to do so could result in electrocution, fire, explosion, or equipment failure.



DANGER: All power connections must be completed by a licensed electrician who is experienced in wiring this type of equipment. Wiring must be installed in accordance with all applicable national and local electrical codes. Improper wiring may cause damage to the equipment, injury or death of personnel. Verify that all high and low voltage input power circuits are de-energized and locked out before installing cables or making any electrical connections.



DANGER: Exercise extreme care when handling unit and battery cabinets to avoid equipment damage or injury to personnel. Cabinets weigh several hundred pounds.



DANGER: Test lift and balance the cabinets before moving. Maintain minimum tilt from vertical at all times. The bottom structure will support the unit only if the forklift forks are completely underneath the unit.



DANGER: Observe all battery safety precautions during installation or service of the unit or batteries. Even with the battery circuit breaker in the off position, the danger of electrocution may still be present. The battery power to the unit must be locked and tagged “off” before performing any service or work on the unit. The battery manufacturer’s safety information and material safety data sheet are located in a pocket attached to the inside of left door of each unit. Failure to follow those instructions and the instruction listed above and elsewhere in this manual could result in an explosion, fire, equipment failure, or electrocution.



DANGER: All power to the unit must be locked and tagged "off" before performing any service or work on the unit. failure to do so could result in electrocution.



DANGER: In case of fire involving electrical equipment, only carbon dioxide fire extinguishers, or those approved for use on electrical equipment, should be used. Use of water on fires involving live high voltage electrical circuits could present an electrocution hazard.



DANGER: Extreme caution is required when performing maintenance. Lethal voltages exist within the equipment during operation. Observe all warnings and cautions in this manual. Failure to comply may result in serious injury or death. Obtain qualified service for this equipment as instructed.



DANGER: Be constantly aware that the unit system contains high DC as well as AC voltages. With input power off and the battery disconnected, high voltage at the filter capacitors and power circuits should discharge within 30 seconds. However, power circuit failures can occur, so you should always assume that high voltage might still exist after shutdown. Verify that power is off using AC and DC voltmeters before making contact.



DANGER: Some components within the cabinets are not connected to chassis ground. Any contact between floating circuits and the chassis is a lethal shock hazard.



DANGER: Internal battery strapping must be verified by the customer prior to moving this unit.

This unit contains non-spillable batteries. Keep the unit upright. Do not stack. Do not tip. Always follow the battery manufacturer's safety information, located in a pocket attached to the inside of the left door of your unit, to prevent an accident that could result in injury or death.



DANGER: Lead-acid batteries contain hazardous materials. Batteries must be handled, transported, and recycled or discarded in accordance with federal, state, and local regulations. Because lead is a toxic substance, lead-acid batteries should be recycled rather than discarded.

Do not dispose of batteries in a fire, the batteries may explode.

Do not open or mutilate the batteries. Released electrolytes are harmful to the skin and eyes and may be toxic.

A battery can have a high short circuit current and present a risk of electrical shock. The following precautions should be observed when working on batteries:

1. Remove watches, rings, or other metal objects.
2. Use tools with insulated handles.
3. Wear rubber gloves and boots.
4. Do not lay tools or metal parts on top of batteries.
5. Disconnect charging source prior to connecting or disconnecting battery terminals.
6. Determine whether battery is inadvertently grounded. If so, remove the source of the ground. Contact with any part of a grounded battery can result in electrical shock. The likelihood of such shock will be reduced if such grounds are removed during installation and maintenance.
7. Lead-acid batteries can present a risk of fire because they generate hydrogen gas. The following procedures should be followed:
 - **Do not smoke when near batteries.**
 - **Do not cause flame or spark in battery area.**
8. Discharge static electricity from your body before touching batteries by first touching a grounded surface.

Chapter 2. Overview

Topics:

- ^ *Product Description*
(page 12)
- ^ *Product Main Features*
(page 15)

This chapter provides an overview of the Three-Phase Power Wave Elevate.

The Power Wave Elevate equipment herein shall be referred to as UPS, Elevator Backup and or Lighting Inverter.

2.1 Product Description

The Three Phase UPS is manufactured to provide critical power for Elevator, Elevator Cab Light and Building Emergency lighting during a power outage. The Battery Backup meets or exceeds the life safety codes of UL924, UL1778 and NFPA101. These codes were established to allow Elevator Battery Backup System to provide critical power to the Elevator as well as compliance with UL924 requirements during a power failure.

The Elevator Battery Backup System equipment herein shall be referred to as UPS.

Three Phase Elevator Battery Backup Standard Series and Seismic series have been certified to UL1778, UL924.

If input power to the inverter is lost during a power outage, the system draws clean sine wave power automatically from its internal battery supply without any interruption and with zero transfer time. Power provided is 120 minutes to elevator and 90 minutes backup for the building emergency Lighting to allow sufficient time for safe and orderly evacuation from the facility and operation of elevators.

The output transformer provides multiple output voltages as well as input voltages that are different than the output voltages. The standard VRLA (Valve Regulated Lead-acid), maintenance-free batteries provide 120 minutes of backup power as standard, sufficient time for safe and orderly evacuation from the facility.

In case of a power failure, Power Wave Elevate a UL924 UPS utilizes a bidirectional operation to provide the backup power to the Elevator up to 2 hours (120 minutes), with delay transfer and still suitable for all lighting loads including per UL 924 any combination for electronic and security systems, Power Factor Corrected Self-Ballast Fluorescent, Incandescent, Quartz Restrike, Halogen, HID, HPS and LED Lighting during battery backup operation.

The Three Phase Battery Backup has an internal bypass circuit, which maintains the power to the load in case of internal system or component malfunction.

The UPS provides optional comprehensive monitoring capabilities. In addition to the LCD display, it provides four facility Interface (Dry Contacts) for remote monitoring capabilities.

The UPS contains optional; AS 400, RS 232, RS485 data transmission ports RJ45 with optional software and many other communication options.

The unit is an on-line three phase PWM high frequency, digital signal processing, Green Mode (Hybrid design), Table 4-1 for available ratings The Elevator Battery Backup System is listed for compliance to UL1778, UL924, UL924A and CSA107.1 standard, and compliant with NFPA 101 (Life Safety Code). The units are available with an input or output voltage of:

- 480Y/277

– 208Y/120 VAC.

2.1.1 Standard Series

Table 2-1 UPS Cabinet Dimensions

KW	UPS Cabinet Size (W x H x D in Inches)	Typical Battery Cabinet (Standard Battery)
24-50KW 30-60KVA	34 x 75* x 31.5	51 x 70 x 30.5 Refer to Figure 4.4
64-128KW 80-160KVA	55.5 x 75* x 31.5	

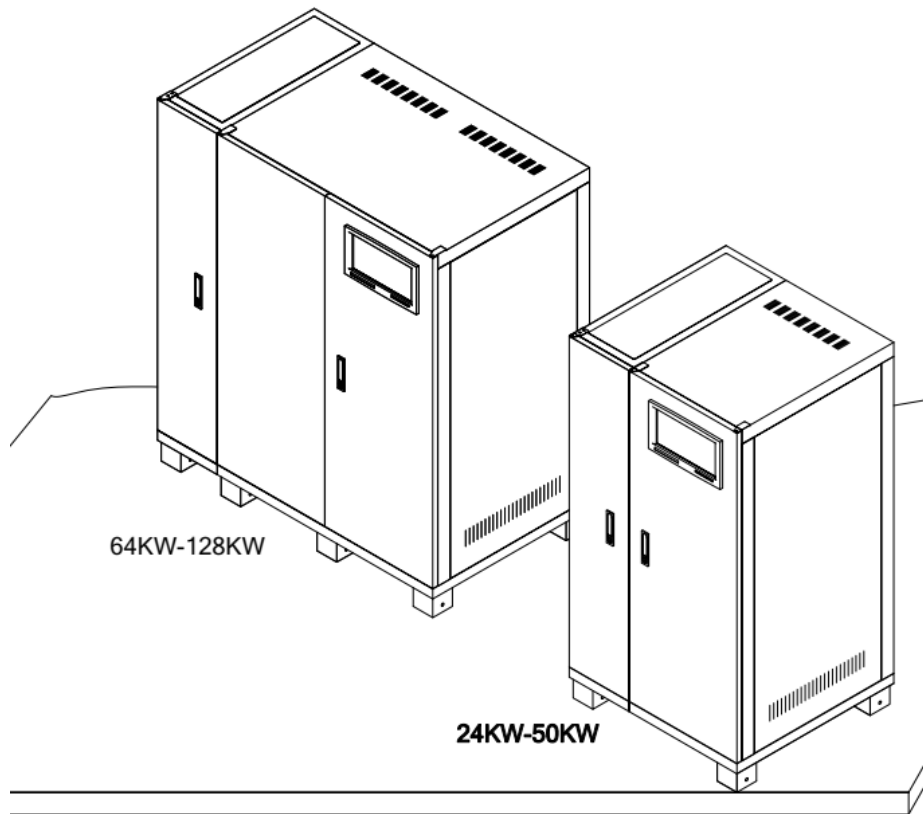

Figure 2.1 UPS Cabinet

* Shaker Table Tested (HCAI OSP) Units have a height of 63"; consult the factory for more details.

Overview

Table 2-2 UPS Cabinet Dimensions for Zone 4 (With Seismic Brackets)

KW	UPS Cabinet Size* (W x H x D in Inches)	Typical Battery Cabinet (Standard Battery)
24-50KW 30-60KVA	40 x 75 x 31.5 (Including brackets)	58.75 x 70 x 30.5 (Including brackets) refer to Figure 4.7
64-128KW 80-160KVA	62 x 75 x 31.5 (Including brackets)	58.75 x 70 x 30.5 (Including brackets) refer to Figure 4.7

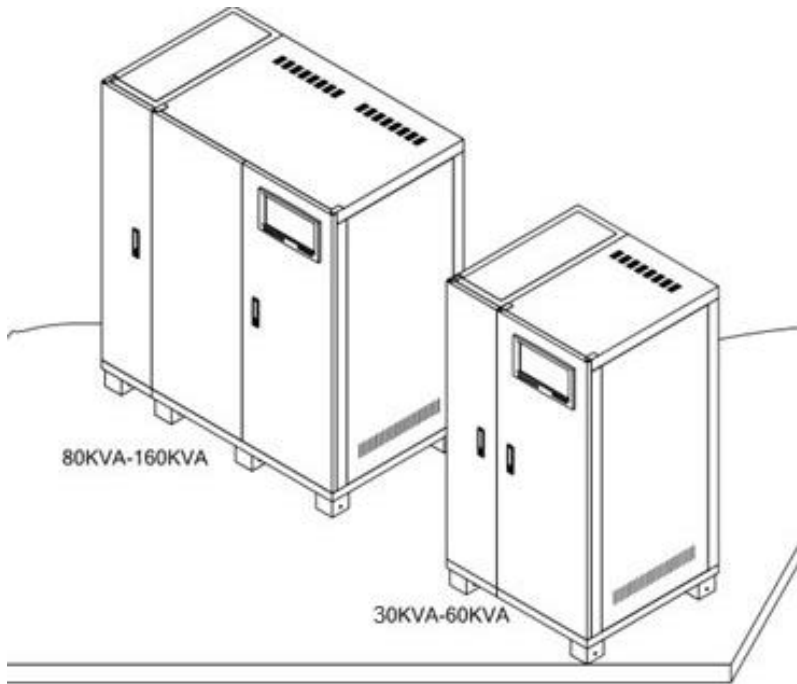

Figure 2.2 UPS Cabinet for Zone 4 (With Seismic Brackets)

* Shaker Table Tested (HCAI OSP) dimensions; consult the factory for more details.

KW	UPS Cabinet Size (W x H x D in Inches)	Typical Battery Cabinet (Standard Battery)
24-50KW 30-60KVA	40.75 x 63 x 31.5 (Including brackets)	58.75 x 70 x 30.5 (Including brackets) refer to Figure 4.7
64-128KW 80-160KVA	62.5 x 63 x 31.5 (Including brackets)	58.75 x 70 x 30.5 (Including brackets) refer to Figure 4.7

2.2 Product Main Features

2.2.1 Rectifier

The main function of a rectifier is to convert the AC input to DC power to the inverter. The inverter then converts the DC power to AC power for the load. UPS uses the most efficient method of charging to charge the batteries which is the DC power.

The UPS uses 6-Pulse or 12-Pulse fully controlled rectification

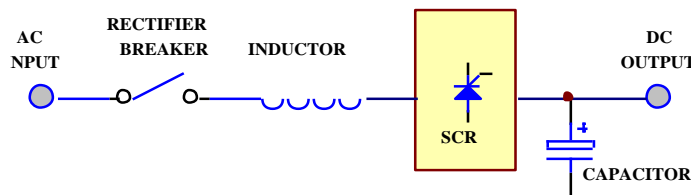

Figure 2.3 6-Pulse full control rectifier

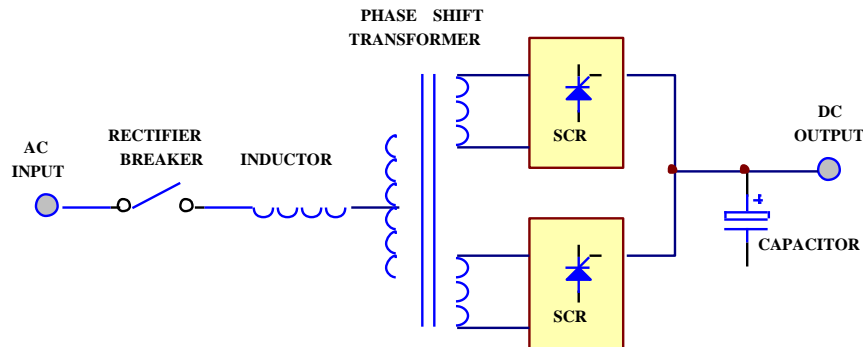

Figure 2.4 12-Pulse full control rectifier

The UPS sizes 10-60KVA use the 6-pulse fully controlled rectification (optional 12-pulse).

Addition of an inductor before rectifier improves the power factor, smooths the current waveform and eliminate the harmonic current.

The control circuit regulates the DC bus within 1%. Soft walk-in circuitry (approximately 20sec.) and current limit circuitry is used to prevent over current or instantaneous surge current. Adding extra undervoltage and overvoltage protection improves the reliability and will shut down the rectifier in case of abnormal conditions. The DC bus is adjustable for different type of batteries. The power

components that are used can handle extreme high current. The rectifier operates under wide range of AC input from 177 to 300 VAC to operate under all power conditions.

The UPS sizes 80kva and above the 12-pulse full controlled rectifier to improve the power factor and reduce harmonic current drawn by the rectifier.

A phase shift transformer is added to reduce the total current harmonic current to about 15% and improve the power factor to over 0.8. The input inductor makes the UPS much more reliable and rugged.

Since the input KVA and harmonic current drawn is minimized, fulfilling the worldwide energy saving requirements the user does not have to increase the input breaker and cable sizes.

A harmonic filter is used to lower the harmonic current. The total harmonic current can be reduced to approximately 9%

The harmonic current can be further lowered by adding harmonic filters (factory installation available). The total harmonic current can be reduced to approximately 9%.

To reduce the harmonic current further down to approximately 7% for larger KVA units, optional 18-Pulse rectifier is available.

2.2.2 Inverter

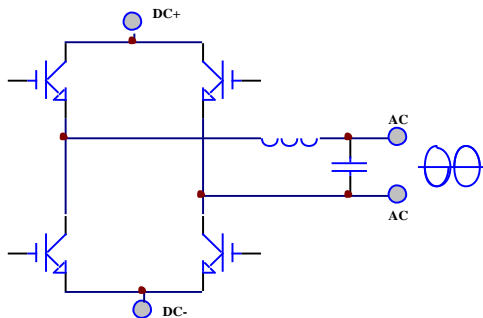

Figure 2.5 IGBT Inverter

The inverter is composed of IGBT, inductor, capacitor, snubber, control circuitry and protection circuitry. The inverter converts the DC power from the DC bus to AC power to supply the output load. The UPS uses IGBT technology which switches at frequencies beyond the audible range, therefore producing no audible noise.

The UPS uses voltage regulation circuitry to limit the voltage variation within 1%. Special compensation circuitry is added to eliminate the output distortion. Every

component is oversized to accept the wide DC input range (from 285 to 420VDC), so that the output waveform remains sinusoidal throughout the range. With the aid of dynamic feedback loop the inverter will keep a sine waveform even under non-linear load.

An independent inverter is used for each phase, each inverter has its independent feedback, so that the voltage is unaffected when load is added to the adjacent phase, producing excellent voltage regulation under 100% unbalanced load.

The IGBT is operated in its optimal condition to obtain best efficiency, so as to reduce the power cost of the user.

Due to more frequent failure of the UPS because of the inverter failure a redundant protection circuit is used to protect the inverter. A strong snubber is added to suppress the spike and noise. Semi-Conductors, fuses and maximum ventilation are integrated in the UPS design to make unit sustain overload and high peak current due to the load, higher efficiency, and improve the unit MTBF.

2.2.3 Static Switch

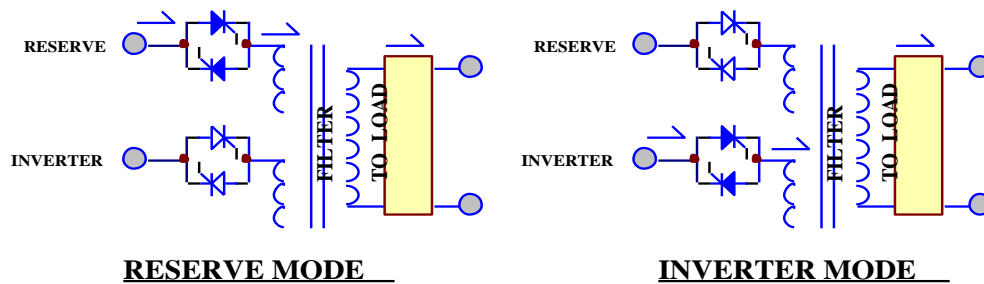

Figure 2.6 Static Switch

The static switch is composed of two pairs of SCRs, connected back-to-back. The switch can transfer the load from reserve to inverter or from inverter to reserve without losing power at the output.

Detection circuitry is added to the control circuit to achieve zero dead time transfer. Additional detection logic is employed to control the static switch should transfer. For example, if under normal mode operation output is short circuited, the UPS detects the short circuit and stops the inverter. The static switch will not transfer the power to the reserve circuit, which could damage the reserve breaker. In case of an overload, the UPS will stop the inverter after a period the inverter can endure, and then transfer the load to the reserve circuit, since the overload capability of the static switch is higher than the inverter.

The transfer action is determined according to the reserve-input voltage and frequency to protect supplying incorrect power to the load. Finally, there is a double check by the CPU as to whether the transfer is successful or not.

2.2.4 Regen Manager

During a power outage, the optional Regen Manager converts regenerative power generated by elevator to DC power supplying power to the batteries thus extending the Battery Backup time. During normal mode, the optional Regen Manager will feed the regenerative power to the building. Additionally eliminating the requirement for a traditional Automatic Transfer Switch (ATS) and its associated circuitry. This reduces the system's footprint, load banks, cooling systems, and the need for onsite maintenance through remote monitoring capabilities.

2.2.5 Power for Elevator Cab (3kW, 120VAC)

The UPS provides 120VAC up to 3kW, 120VAC power for Elevator Cab Lighting.

2.2.6 Emergency Power Display

This LED is illuminated to notify the user the UPS is operating on Emergency Power.

2.2.7 Internal Maintenance Bypass Breaker

The maintenance bypass switch (Breaker) is installed inside the unit should be open under normal operation, and only closed during maintenance. The maintenance bypass switch is a necessity to maintain AC power to the load while performing maintenance on the unit. When the bypass breaker is closed under normal operation, the inverter will stop and the load will be automatically transferred to reserve to prevent the inverter connecting directly to the AC source, however you cannot switch on the inverter as long as the maintenance bypass breaker is closed.

➤ Using the maintenance bypass breaker

Switch off the inverter

The static switch will automatically transfer the load to reserve without dead time

Close the maintenance bypass breaker

Open the reserve breaker

The load gets power from the output without interruption.



DANGER: All power to the unit must be locked and tagged "off" before performing any service or work on the unit. Failure to do so could result in electrocution.

For Safety of the maintenance personnel disconnected all power to the UPS before touching any parts inside the unit

2.2.8 Main Input Circuit Breaker

The main input circuit breaker provides the unit with incoming power isolation as well as means of disconnect and input over current protection.

2.2.9 Main Output Circuit Breaker

The main output breaker provides output overcurrent protection

2.2.10 Battery Circuit Breaker

The battery circuit breaker provides overcurrent protection for battery bank.

2.2.11 Inverter Test Switch

Inverter test switch is a push button switch for testing the unit for proper operation. When unit is running and switch is pressed, the unit will automatically transfer to battery operation. The unit will continue to run on batteries until the switch is released. When the switch is released, the unit returns to normal operation (provided input power is present).

2.2.12 Battery

The battery bank consists of 29 (12-volt) batteries. Batteries are housed in external cabinet providing the reserve energy to sustain the load when suitable AC input power is not present. The batteries are designed and tested to meet UL 924 requirements. The standard VRLA (Valve Regulated Lead Acid) batteries are sealed and maintenance-free. Refer to battery connection diagram within the cabinet door.

Consult factory for all other battery type options.

2.2.13 Intelligent Battery Charger

The charger will automatically recharge (boost charge) the batteries every time the batteries are depleted to a voltage level equal to 2V/Cell. Thus, the batteries can be restored to full capacity upon restoration of input power. In order to keep the batteries in the best condition, the UPS will boost charge the batteries for several hours

(selectable) automatically every month. To avoid over charging the batteries, boost charge will stop when the ambient temperature is over 35°C (95°F).

2.2.14 Optional Seven (7) Dry Contacts

Seven (7) dry contact terminals shall be provided. These terminals are Normally Closed (conducting), dry contact. When an event occurs, the terminal will open (non-conducting). Maximum contact rating is 16A/250VAC (16A/30VDC). The connections provided are:

- Inverter ON
- Output Overload
- UPS Fault
- Charger OFF
- Bypass ON
- Battery Low
- Summary Alarm

2.2.15 Provision for 2 (two) optional Sub-Feed UL489 Breakers for Elevator and Emergency Lightings.

These optional breakers ratings can be specified per required power.

2.2.16 Optional Selectable time-delay (60 or 120 seconds) Battery to Utility

Optional Selectable time-delay (60 or 120 seconds) to allow elevator control to switch to normal power.

Chapter 3. Hardware Overview

Topics:

- ^ *Key Components (page 22)*
- ^ *Functional Description (page 25)*
- ^ *General Topology (page 27)*
- ^ *Modes of Operation (page 29)*
- ^ *System highlighted features (page 31)*

This chapter provides an overview of the system hardware. It includes a description of the system's theory of operation.

3.1 Key Components

shows the typical key system components and Table 3-1 describes them.

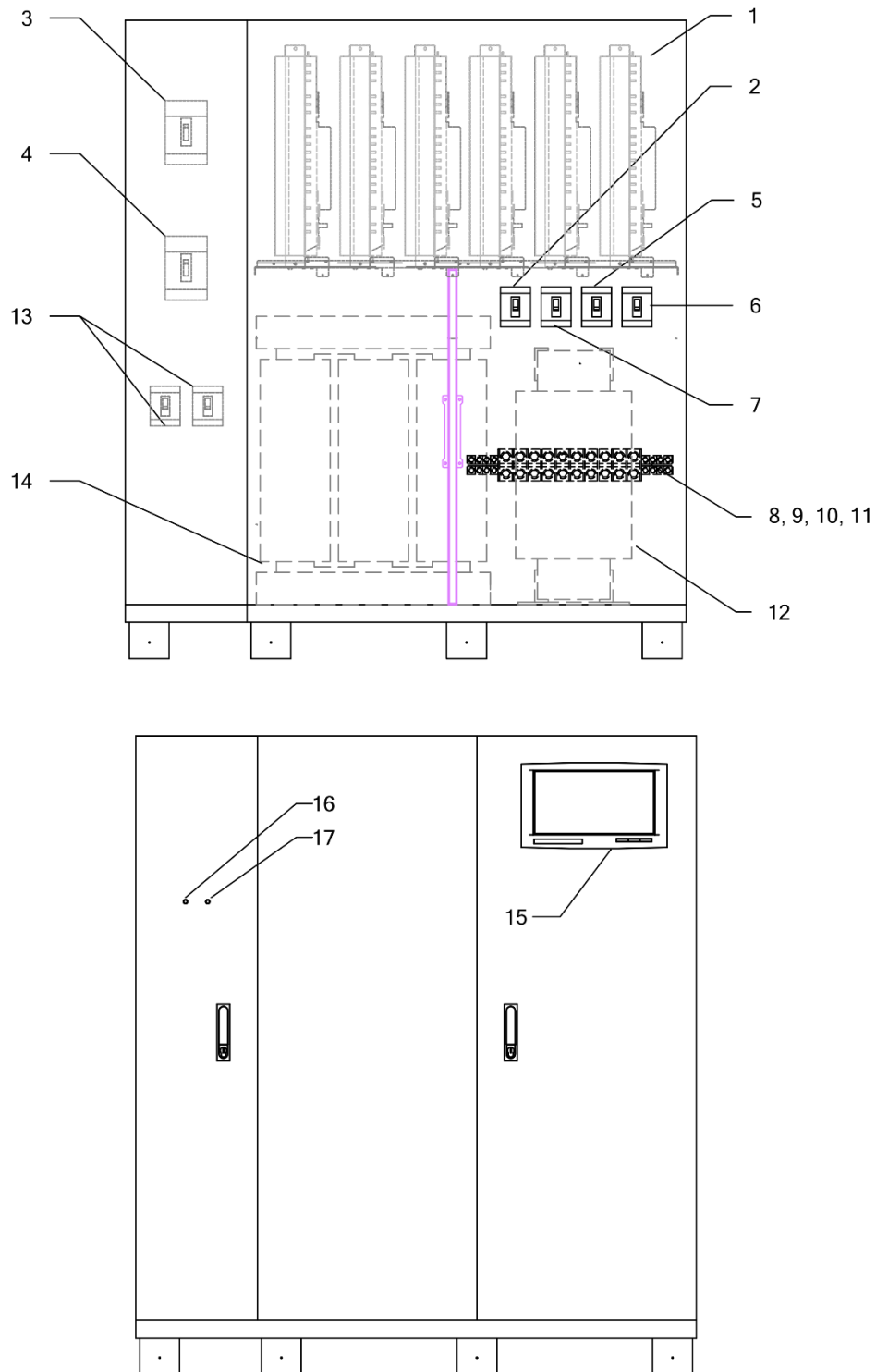

Figure 3.1 Key Components typical location (shown 64-128KW)

Table 3-1 Components description

Callout	Component Name	Description
1	Inverter assembly Rectifier / Static Transfer assembly (6 pulse) Rectifier assembly (12 pulse) Static transfer (12 pulse)	These FRU (Field Replacement Assemblies) are design as module, easy to troubleshoot, and replace for each system. Refer to Table 6-1 for ordering details.
2	Main Input breaker	Provides input overcurrent protection.
3	Battery breaker	Provides overcurrent protection for battery bank.
4	Main output breaker	Provides output overcurrent.
5	Reserve Breaker	In case of UPS maintenance or battery replacement, when the load cannot be interrupted, turning off the inverter and closing the Bypass breakers and opening the Reserve and Rectifier breaker will provide power from reserve to the load.
6	Bypass Breaker	Under normal operation closing this breaker will stop the inverter and transfer the load automatically transfers to reserve to prevent the inverter connecting directly to the AC source. However, the unit will not switch on the inverter as long as the maintenance bypass breaker is closed.
7	Rectifier Breaker	Rectifier Circuit breakers will protect the unit against abnormal condition in either rectifier or load.
8	Input Terminal Block	Input power connection, ØA, B, C and Neu, see Figure 4.8.
9	Output Terminal Block (4 Pole)	Output power connection, ØA, B, C and Neu, see Figure 4.8.
10	Battery Terminal Block (3 Pole)	DC (battery) Connection (+), (-), Gnd., see Figure 4.8.
11	All other Interfaces	All other Interfaces, see Figure 4.8 for Detail
12	Output isolation transformer	The Output isolation transformer of a true Galvanic isolation can solve the problem of poor input grounding, can allow a different ground between input and output, can avoid the annoying problem of ground leakage current, and can be tied to any potential provided on site. The AC output is isolated under every mode of operation. Additionally, the user gets the bonus of attenuation of common mode noise from the output isolation transformer.
13	(Optional) Sub-Feed Breakers	Provision for Two (2) Sub-Feed Breakers (customer to specify ratings) -One (1) Breaker to feed the Elevator Panel (UL489) -One (1) Breaker Emergency Lighting Panel. (UL489)
14	Input Transformer	

Hardware Overview

Callout	Component Name	Description
15	Front Panel & LCD display	See 5.5 and 5.6 for details
16	Front Panel LED	Amber LED illuminates when Regen Manager is Active (behind the front door)
17	Front Panel LED	Red LED illuminates when Regen Manager alarm comes on (behind the front door)

3.2 Functional Description

Following figures shows the system typical Block Diagrams and the section 3.3 describes the typical topography of the UPS.

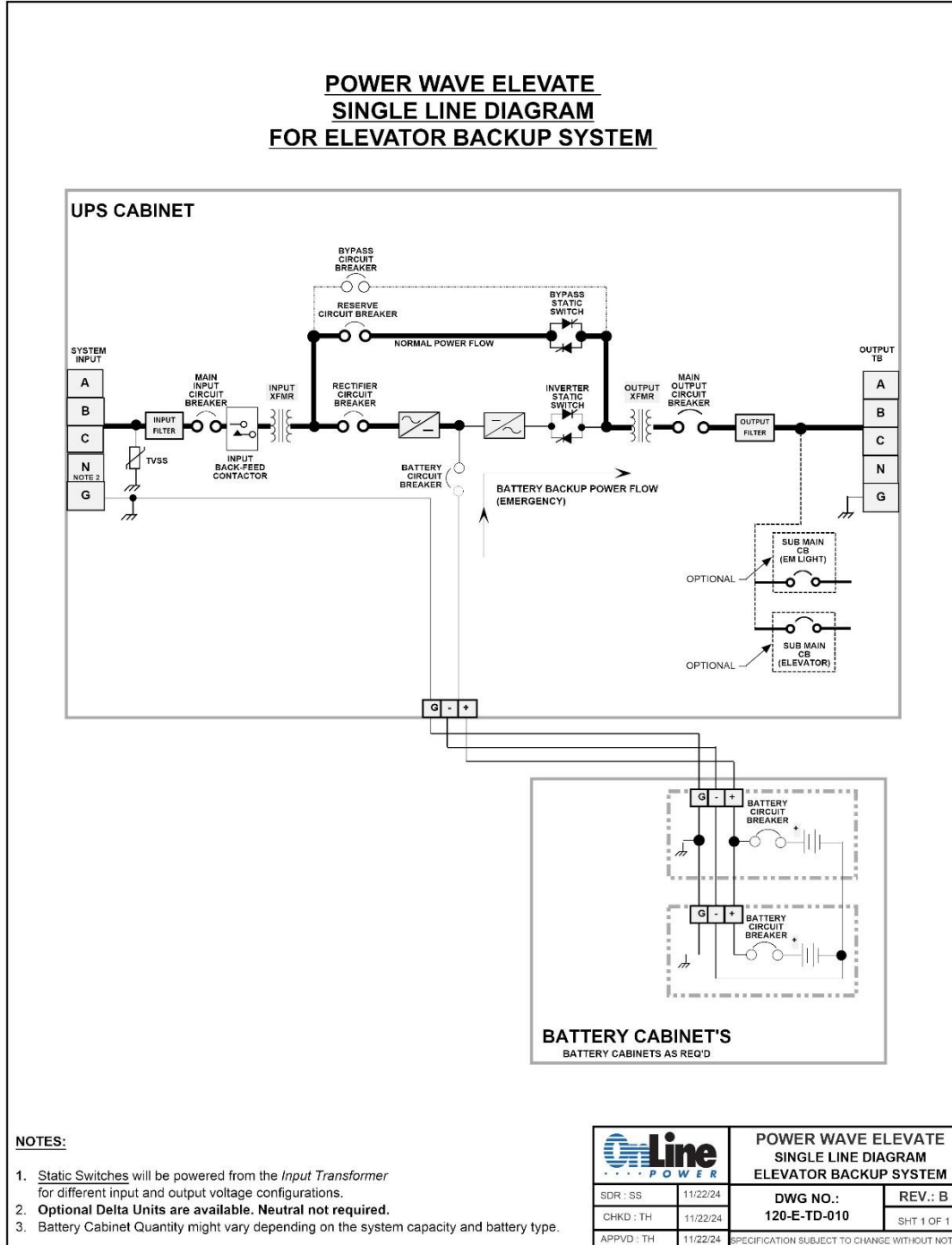

Figure 3.2 System Blocks Diagram

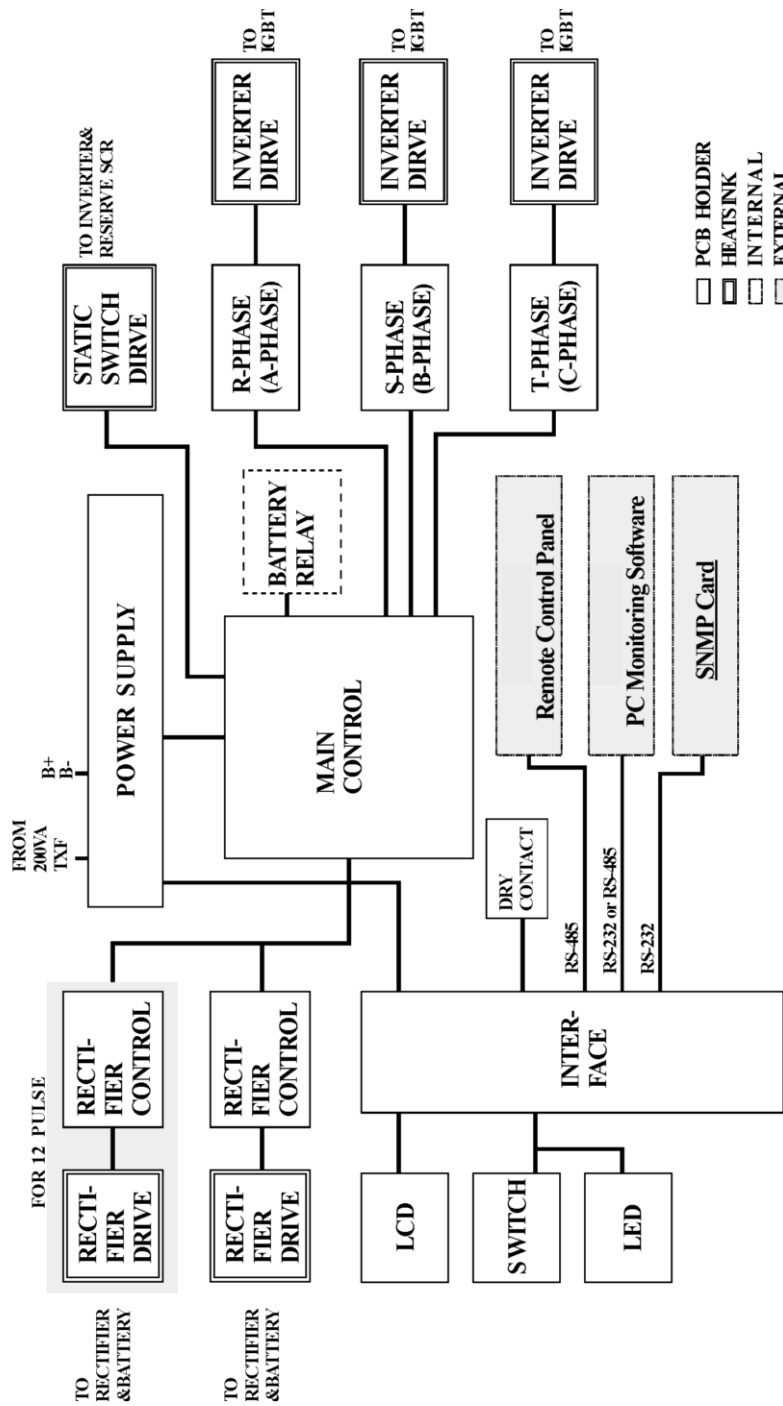
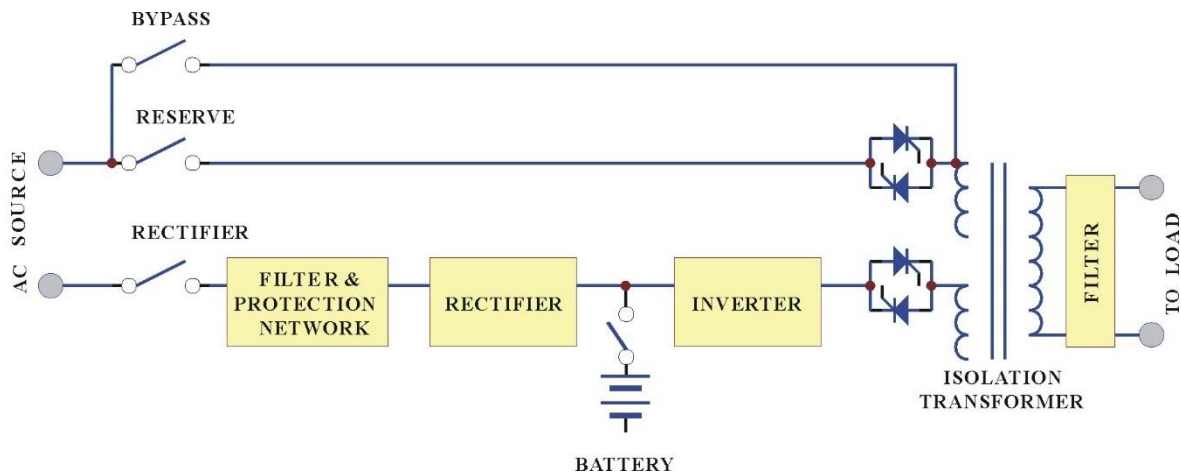

Figure 3.3 Inter PCB Diagram

3.3 General Topology



The Unit is composed of input breakers, input filter & protection network, rectifier, battery bank, inverter, static switch, bypass breaker, isolation transformer and output filter. The basic topology is shown in the diagram above. Under normal AC mode, energy from the AC source is converted to DC power and supplied to the inverter to charge the batteries to its full capacity all the time, ready to support the output load in case of AC source failure.

Although the principle and operation of the UPS seems simple and straightforward, the requirement for a reliable and intelligent UPS makes the design and manufacturing of a high reliable UPS requiring advanced technology, intelligence, experience and most important, consideration of the user interface.

The most obvious specification, output power, depends on the size of the load. Often, an allowance of 50% more power is added to the present load requirement, both for tolerance and for future expansion.

Another important issue is reliability. The prime aim of a UPS is to protect your load. Therefore, the System should be much more reliable than the AC source. An unreliable UPS may suffer the problem of frequent break down, even more frequent than AC failure, and the cost of repair may become more than the cost of the unit itself.

Generally, there are four different modes of operation:

- **Normal Operation Mode**
- **Back-up Mode**
- **Reserve Mode**
- **Maintenance Bypass Mode**

These operational modes are detailed in the following section

3.4 Modes of Operation

3.4.1 Normal Operation Mode, Green Mode (High efficiency or Hybrid design)

Hybrid design for higher efficiency (fast transfer less than 2ms). The rectifier converts the AC input to DC power to supply the inverter and charge the batteries simultaneously. All the fluctuations, surges and spikes of the AC input are removed during AC to DC conversion. Therefore, the AC supplied by the inverter is clean and stable.

3.4.2 Back-up Mode

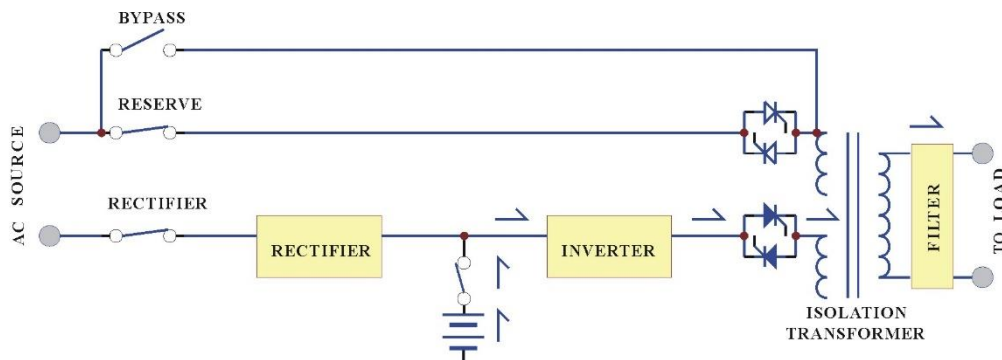

Since the batteries are connected directly to the DC bus, when the AC fails, the batteries change immediately from receiver to donor, supplying energy to the inverter instead of receiving energy from the rectifier. The output AC is not interrupted. Therefore, the load connected to the output is protected.

3.4.3 Reserve Mode

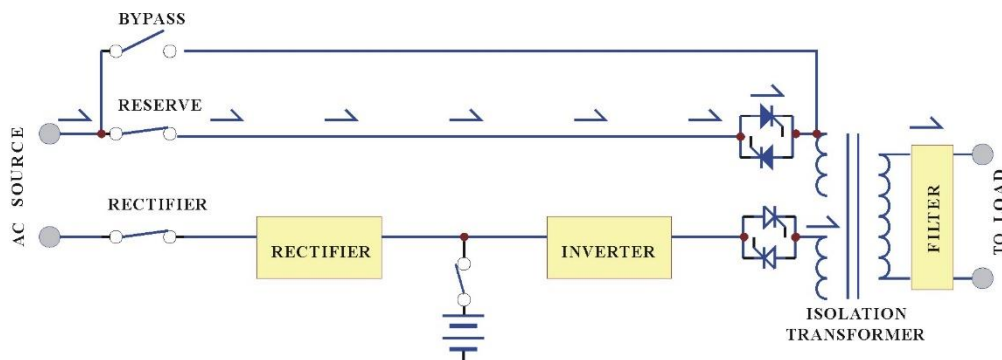

When the inverter is in an abnormal condition, such as over temperature, short circuit, abnormal output voltage or overloaded for a period exceeding the inverter's limit, the inverter will automatically shut down in order to protect itself from damage.

If the utility power is normal, the static switch shall transfer the load to the reserve source without interruption of AC output.

3.4.4 Maintenance Bypass Mode

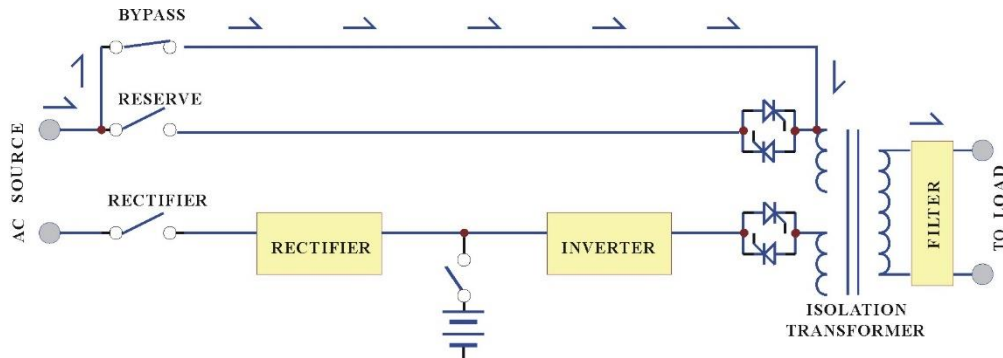

In case of UPS maintenance or battery replacement, and where the load cannot be interrupted, the user can turn off the inverter, close the bypass breaker and then open the rectifier and reserve breakers. The AC output will not be interrupted during manual bypass transfer procedure. Therefore, the maintenance bypass switch keeps continuously supplying power to the load. Electricity will not exist in the UPS except the output transformer, thus ensuring the safety of service personnel.

Generally, the Unit is expected to run 24 Hours a day in normal operation mode once it is installed, except when the utility power fails, under overload conditions, or during maintenance.

Normal operation with batteries connected provides clean, stable, regulated and uninterrupted power to the load, free from any spikes and surges. Therefore, the UPS can be regarded as a perfect AC power source, limited in back-up time, under mains failure, only by the capacity of the batteries.

3.5 System highlighted features

3.5.1 Reliable input protection:

Circuit breakers are placed in each individual input loop to ensure power can continue through another loop in case of breaker trip caused by an abnormal condition in either rectifier or load.

3.5.2 Input surge protection:

An MOV (surge protector) is added at the input, providing protection to both UPS and the load from any lightning surges, or surges caused by neighboring large loads.

3.5.3 EMI suppression:

An EMI filter is added to meet the international EMC limits. Therefore, very low noise is emitted, and no interference is supplied to other equipment connected to the same AC source.

3.5.4 Ruggedness:

The rectifier employs phase control technology to regulate the DC bus voltage. This is the most efficient method to charge the batteries. The SCR used are inherently rugged. Additionally, a large inductor is added at the input to avoid deforming the AC source waveform.

3.5.5 High frequency design:

The inverter uses high frequency, high efficiency IGBT, PWM methodology to convert the DC power to AC power. Therefore, the number of components is fewer, reliability is improved, and the size and weight of UPSI is reduced, performance is improved, and acoustic noise is minimized.

3.5.6 True Galvanic isolation:

An isolation transformer is placed at the output. This can solve the problem of poor input grounding, can allow a different ground between input and output, can avoid the annoying problem of ground leakage current, and can be tied to any potential provided on site. The AC output is isolated under every mode of operation. Additionally, the user gets the bonus of attenuation of common mode noise from the output isolation transformer.

3.5.7 Protection against misuse:

The UPS is designed with breaker on/off sensor, power supply sensor, etc. Therefore, any operational mistake made by the user causes no harm to the UPS.

3.5.8 Accepts wide input range:

The UPS is designed to accept a wide input range, so that it can work effectively under an unstable AC source. All of the input components used are specifically selected to handle extreme high voltage and high current.

3.5.9 Operating environment:

Each component of the UPS is chosen with large safety margin to accommodate extreme environments, such as temperature, humidity, altitude, shock or contamination.

3.5.10 Intelligent charger:

The unit will automatically recharge (boost charge) the batteries every time the batteries are depleted to a voltage level equal to 2V/Cell. Thus, the batteries can be restored to full capacity as soon as possible, and made ready for the next back-up requirement. In order to keep the batteries in the best condition, the UPS will boost charge the batteries for several hours (selectable) automatically every month. To avoid over charging the batteries, boost charge will stop when the ambient temperature is over 35°C (95°F).

3.5.11 Intelligent battery test:

The batteries are tested after every boost (initiated by battery discharge or by the monthly boost charge cycle). This is done without interrupting the operation of the rectifier, preventing the risk of output AC failure in case of a bad battery. The user is informed of the battery condition, so that action can be taken before the full capacity of the batteries is needed.

3.5.12 High charging power:

The charging power is selectable (Lo/Me/Hi) according to Ah rating of the batteries and can charge up battery banks providing more than 8Hrs back-up time without adding an additional charger.

3.5.13 MTBF of fans are extended:

Fans are used to cool the Lighting Inverter, are designed to slow down under light load, so that the life expectancy of the fans is extended beyond the normal.

3.5.14 Redundant power supply:

A supplemental power supply is added to provide redundancy for supplying power to the static switch, so that there will be AC output no matter what happens to the UPS.

3.5.15 Options

With built-in intelligent communication interface as well as output ports of RS-232, RS-485, and dry contacts, there are several options are hence available such as remote-control panel, 3 phases software for PC monitoring, auto dialing module, battery monitoring module, 3 phases SNMP card. Refer to section APPENDIX B - for options details.

Chapter 4. Installation

Topics:

- ^ *Delivery Space Requirements (page 35)*
- ^ *Site Considerations (page 43)*
- ^ *Delivery and Handling (page 46)*

This chapter describes how to install the system. It includes pre-installation information along with guidelines for storing the system for future use.

4.1 Delivery Space Requirements

Verify that the delivery area, the destination, and the path between them meet the standard delivery clearance and weight requirements of the system.

The delivery area must provide enough space and floor strength to support the packaged equipment cartons for the system. Doorways and hallways must provide enough clearance to move the equipment safely from the delivery area to the destination. Permanent obstructions such as pillars or narrow doorways can cause equipment damage. If necessary, plan for the removal of walls or doors.

Verify that all floors, stairs, and elevators you use when moving the system to its destination can support the weight and size of the equipment. Failure to do so could damage the equipment or your site.

The following figures show the dimensions of the system cabinets as well as key components used for cable access and mounting.

**ELECTRONIC
CABINET ONLY
(24KW - 50KW)**

**POWER WAVE ELEVATE
ELEVATOR BATTERY BACKUP**

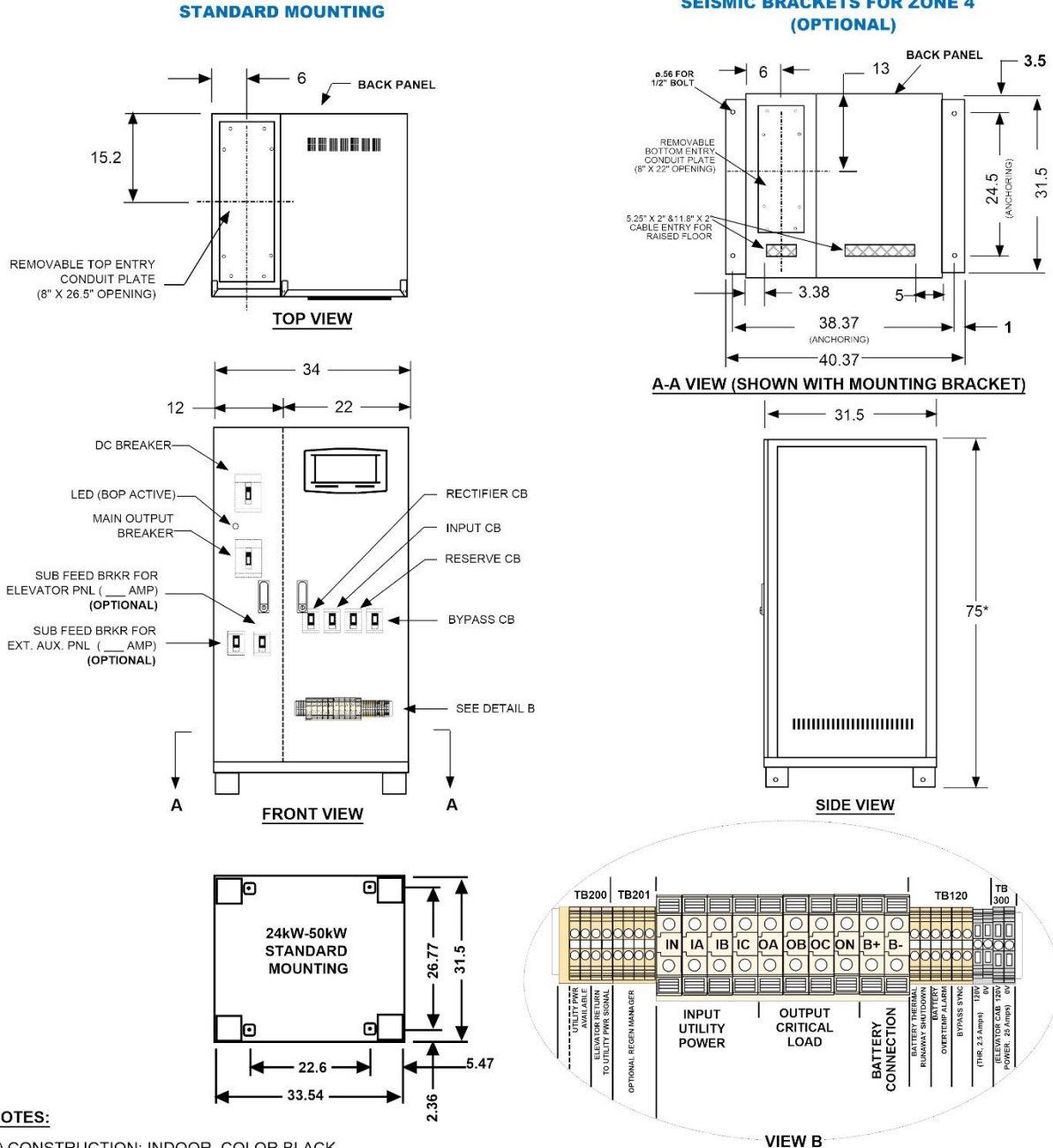

NOTES:

- 1) CONSTRUCTION: INDOOR, COLOR BLACK
- 2) KNOCKOUTS ON CONDUIT PLATES TO BE DONE BY INSTALLING CONTRACTOR
- 3) DIMENSIONS ARE IN INCHES
- 4) *SHAKER TABLE TESTED (HCAI OSP) UNITS HAVE A HEIGHT OF 63". CONSULT THE FACTORY FOR MORE DETAILS

INPUT NEUTRAL (IN) NOT REQ'D FOR DELTA INPUT. MUST BE SPECIFIED AT THE TIME OF ORDERING

Figure 4.1 UPS Cabinet (24 - 50 KW) Access, Standard and Mounting Brackets

**POWER WAVE ELEVATE
ELEVATOR BATTERY BACKUP**

**ELECTRONIC
CABINET ONLY
(64KW - 128KW)**

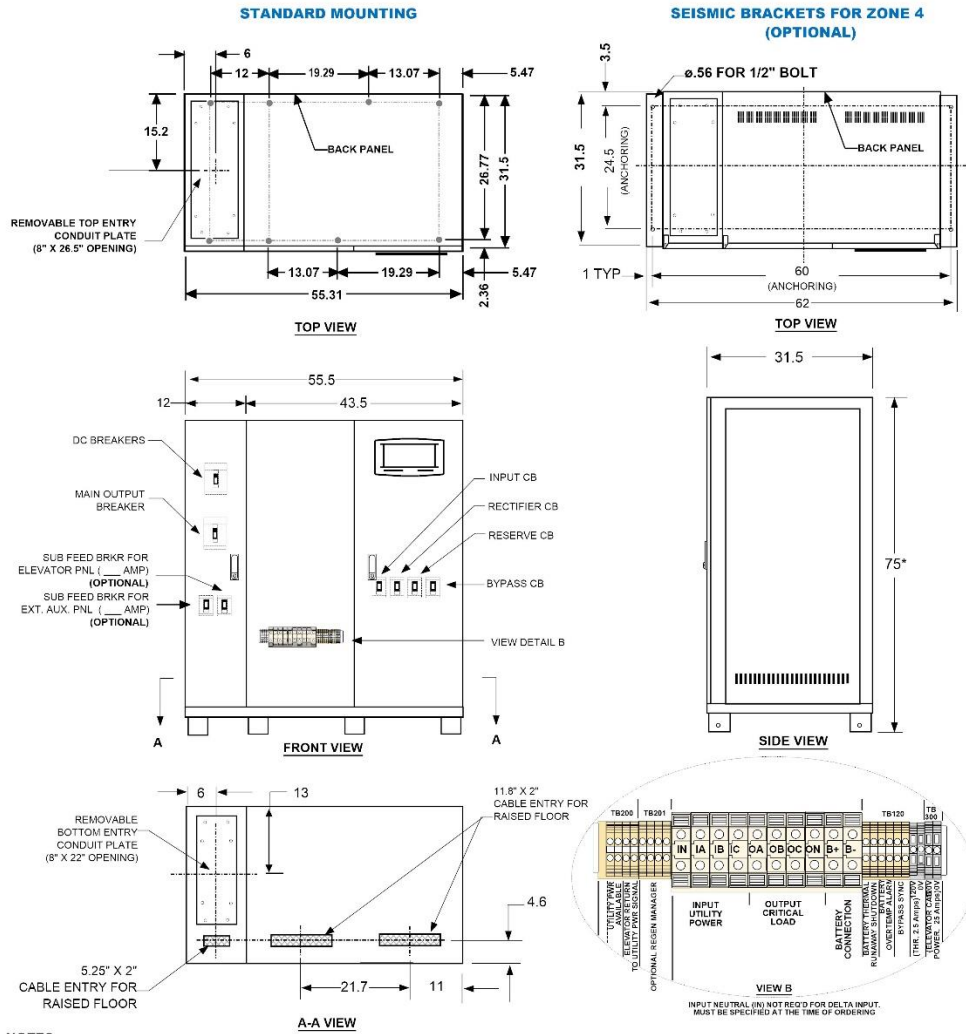

- NOTES:**
- 1) CONSTRUCTION: INDOOR, COLOR BLACK
 - 2) KNOCKOUTS ON CONDUIT PLATES TO BE DONE BY INSTALLING CONTRACTOR
 - 3) DIMENSIONS ARE IN INCHES
 - 4) *SHAKER TABLE TESTED (HCAI OSP) UNITS HAVE A HEIGHT OF 63". CONSULT THE FACTORY FOR MORE DETAILS

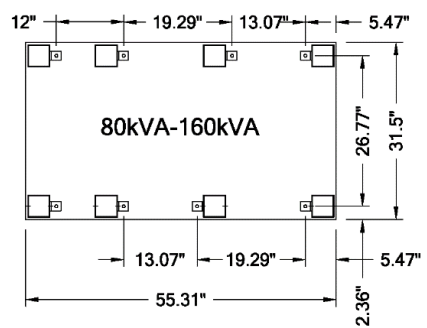

Figure 4.2 UPS Cabinet (64 - 128 KW) Access, Standard and Mounting Brackets

Installation

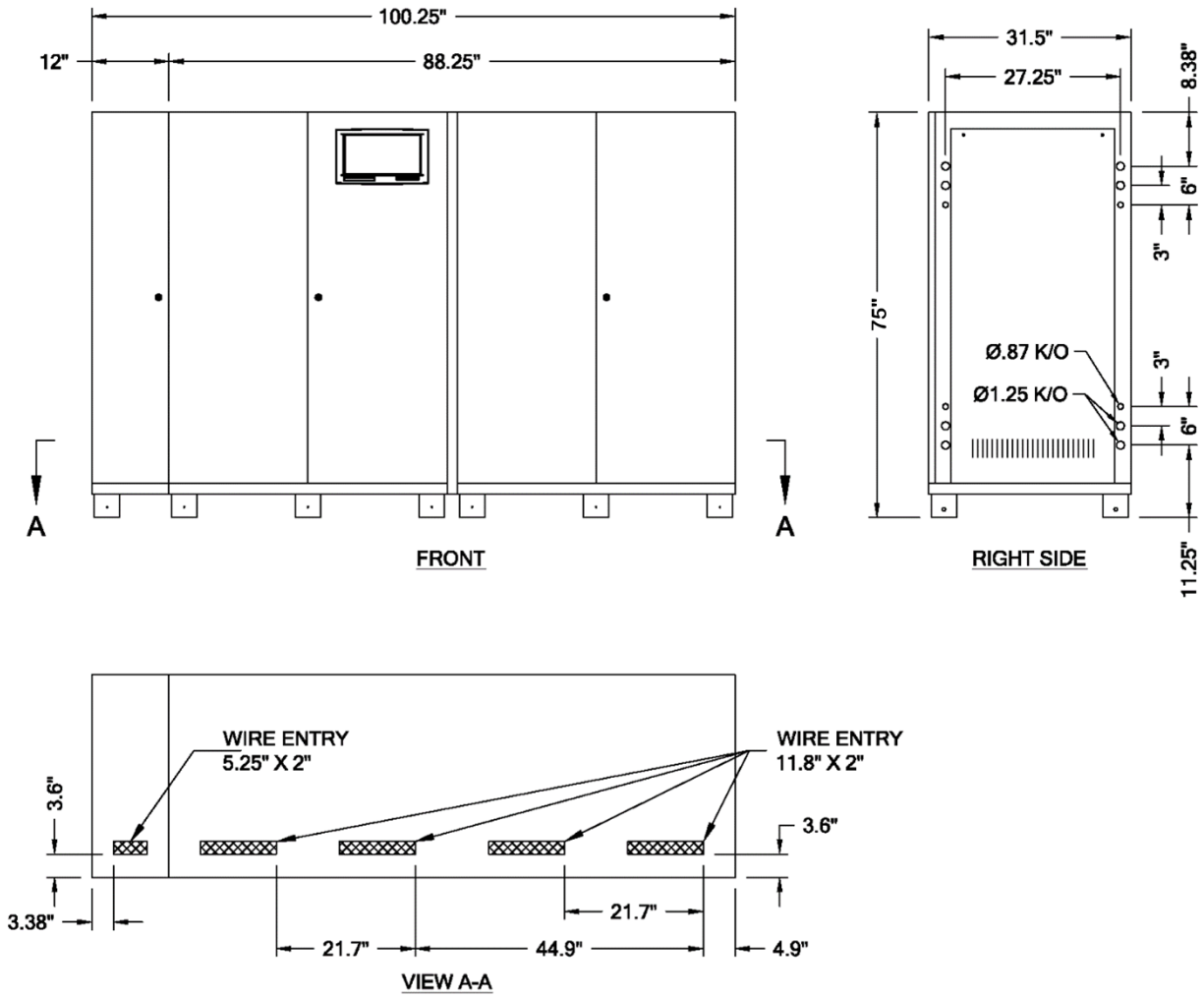
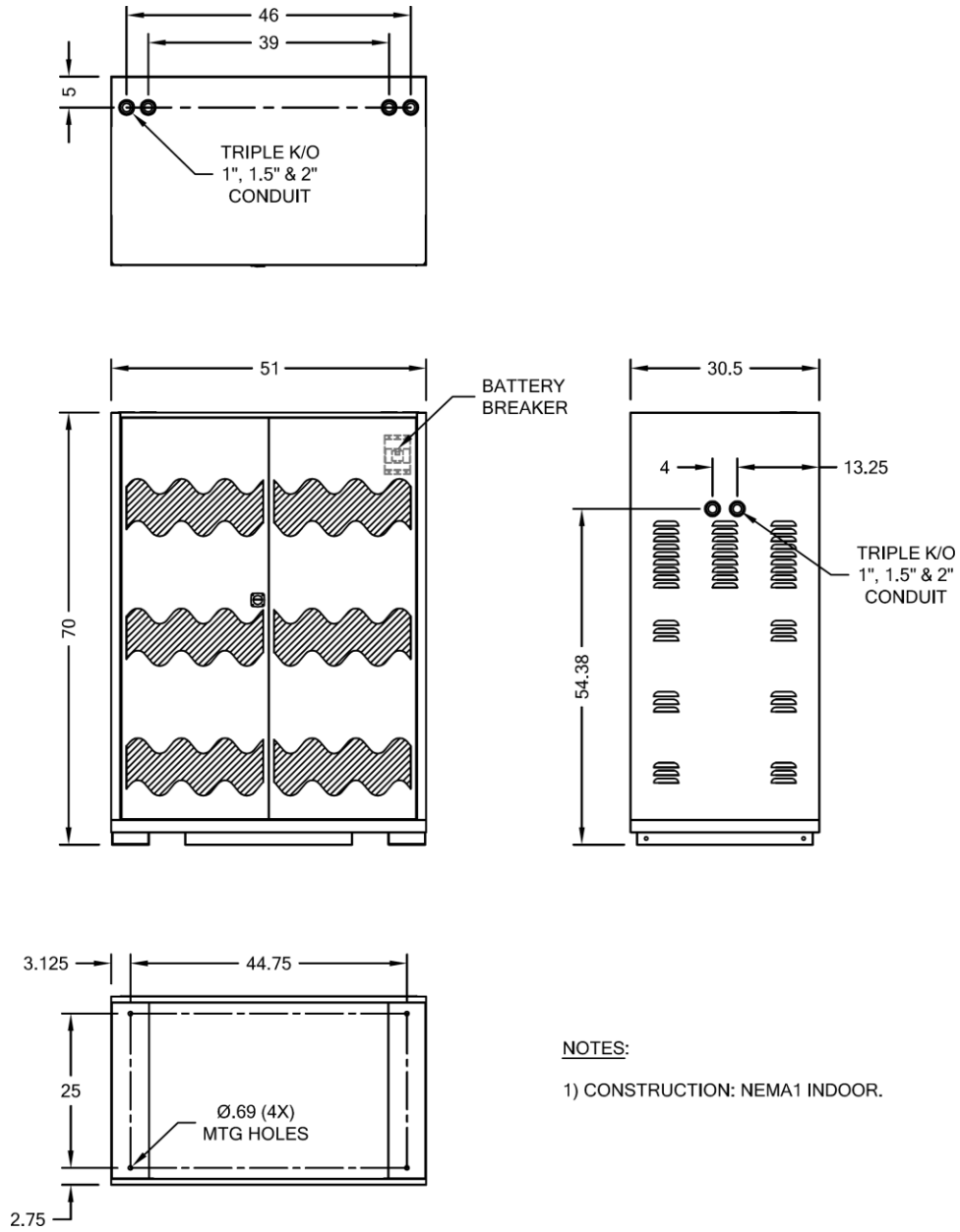

Figure 4.3 UPS Cabinet (160 - 240 KW) Access and Mounting

Installation



NOTES:

- 1) CONSTRUCTION: NEMA1 INDOOR.

Figure 4.4 Typical Battery Cabinet Access and Mounting

Installation

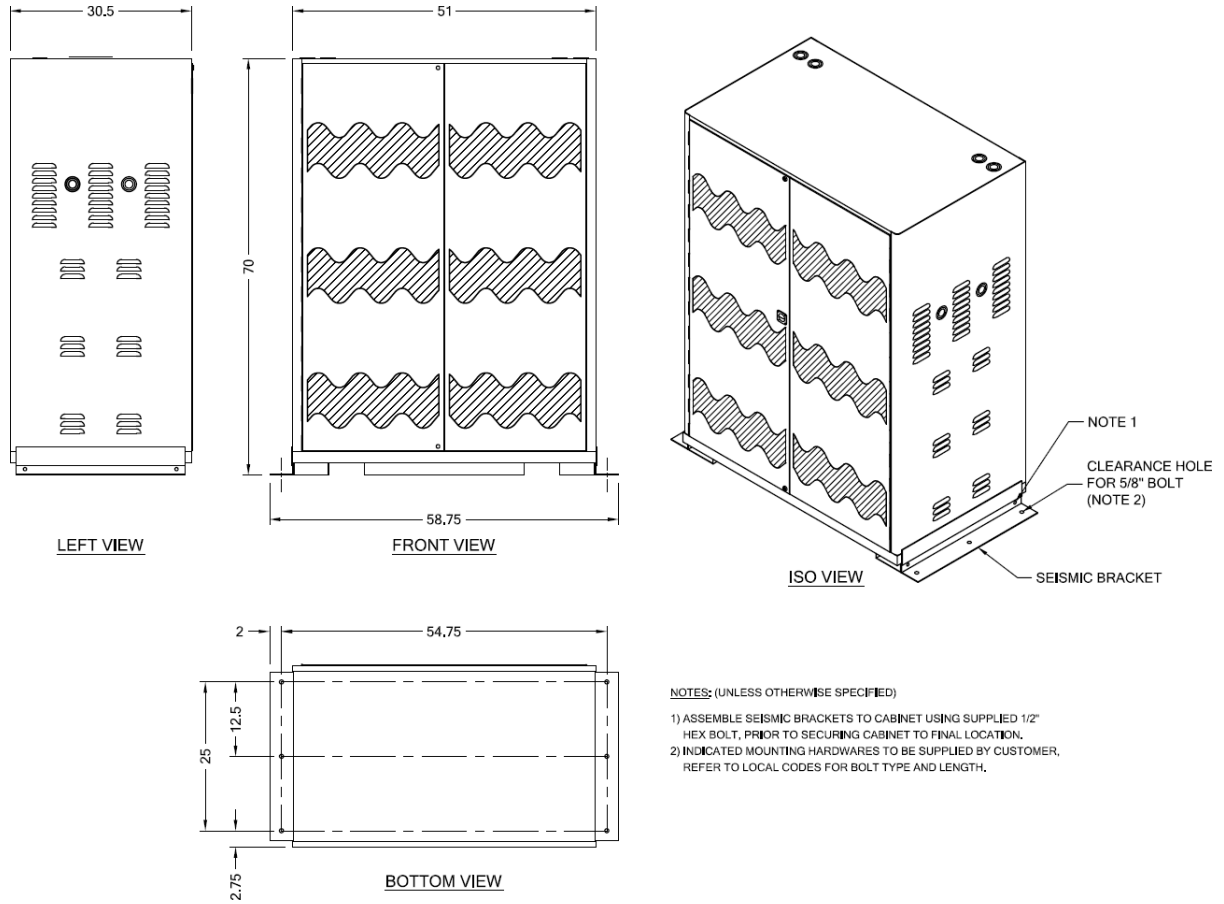
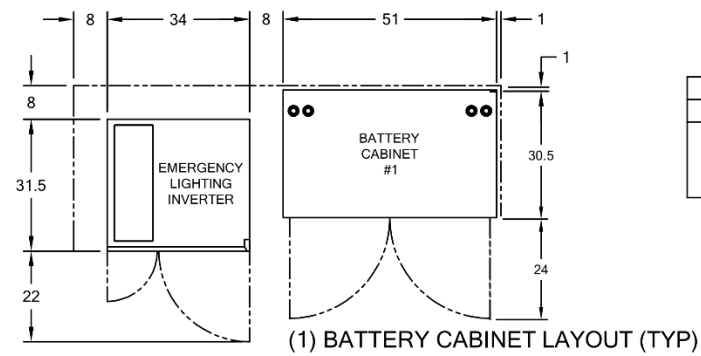
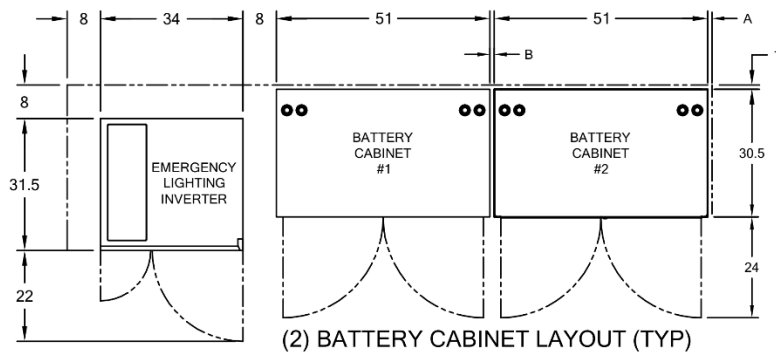
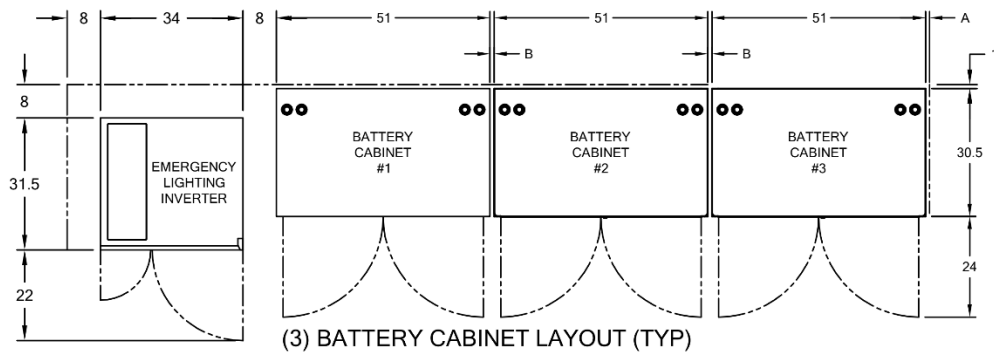
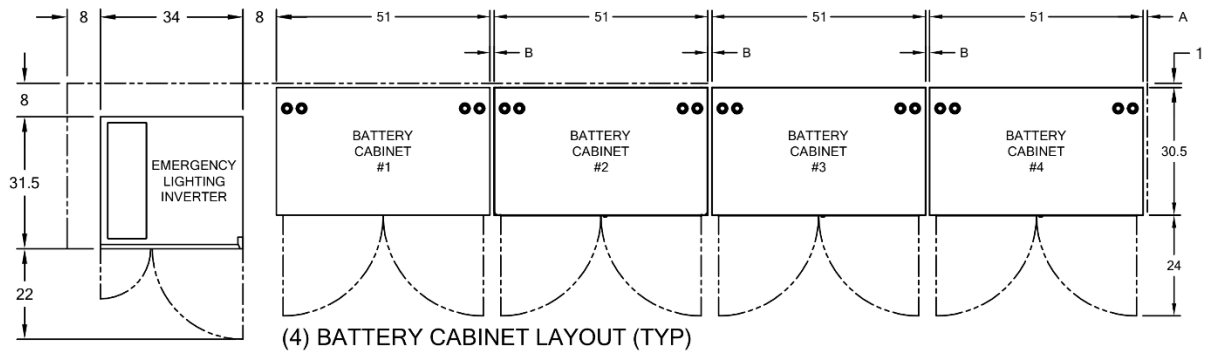

Figure 4.5 Typical Battery Cabinet Access and Mounting (with Optional Mounting Brackets)

Installation



B	1.0"	8.0"
A	1.0"	4.0"
DIM	WITHOUT EXTERNAL SEISMIC BRKT	WITH EXTERNAL SEISMIC BRKT

Figure 4-6 Typical system layout for 24-50KW (refer to battery requirements)

Installation

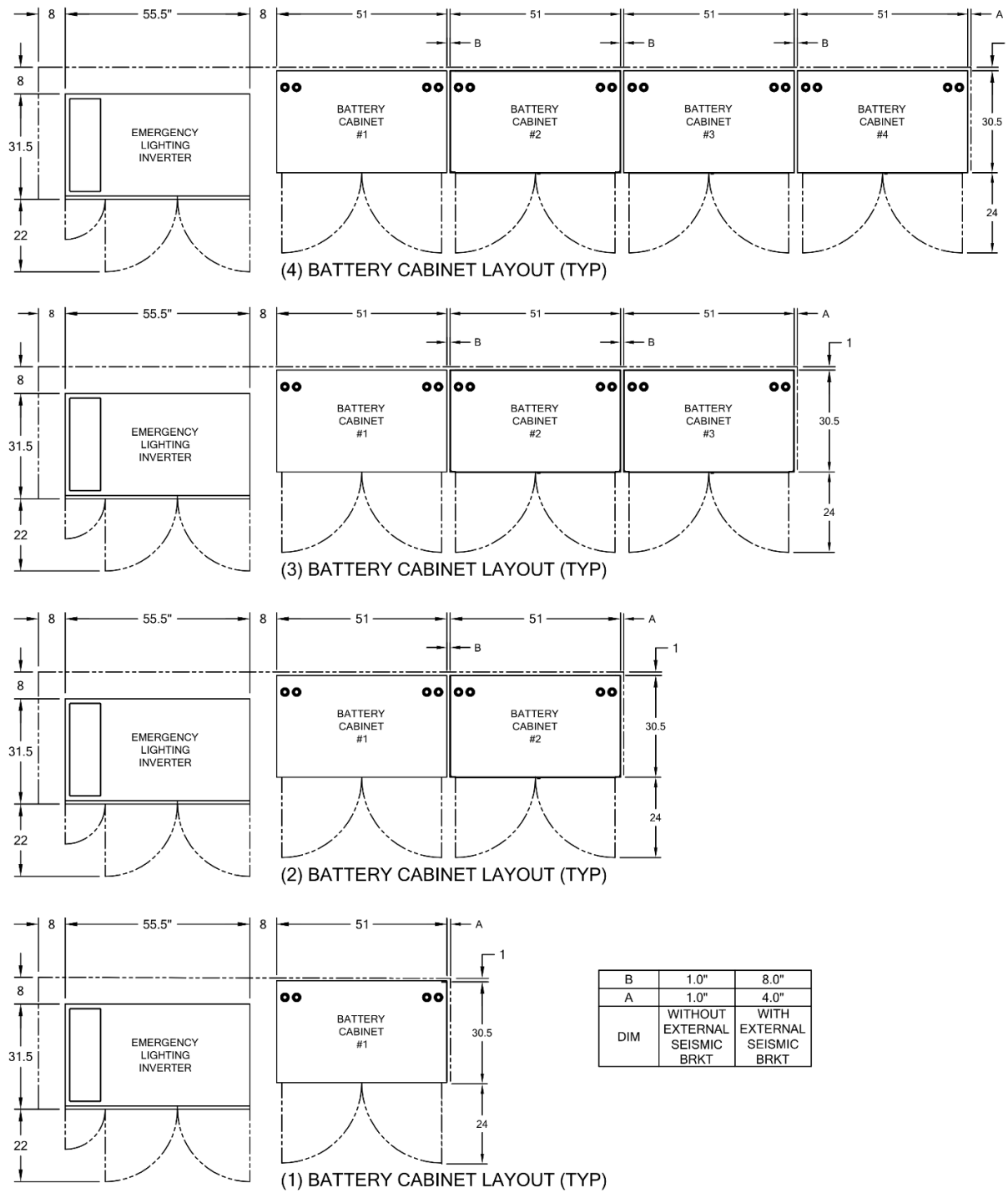

Figure 4-7 Typical system layout for 64-128KW (refer to battery requirements)

4.2 Site Considerations

Planning the proper location and layout of the system prior to installing it is essential for successful operation. To ensure normal operation and to avoid unnecessary maintenance, plan your site configuration and prepare your site before installation.

The UPS and its associated Battery Cabinet(s) are designed for indoor installation and meets NEMA specifications for operating temperature, humidity, and utility voltage. The system enclosures are rugged and corrosion resistant.

All servicing is performed through the front of the unit; therefore, leave sufficient room in the front of the unit for service access (see Figure 4.1 and Figure 4.2) for recommended system layouts.

The following precautions will help you plan an acceptable operating environment for the system:

- Select a flat location that is clean, with no dust or exposure to direct sunlight or vibrations. The location should provide a sturdy, level surface that can support the system. Avoid locations with inclined floors.
- The location should not be prone to variations in temperature and humidity or be close to strong magnetic fields or a device that generates electric noise.
- The Unit should not be placed next to, on top of, or below any device that generates heat or will block the free flow of air through the system's ventilation slots. The installation location must provide adequate exhaustion.
- The UPS cabinets provides conduit plates on the top and bottom (for Raised floor), its battery cabinets provide cable and conduit openings on the top and sides of the cabinet. Be sure these areas are not blocked and can be easily accessed to expedite installation.
- Electrical equipment generates heat. Ambient air temperature might not be adequate to cool equipment to acceptable operating temperatures without adequate circulation. Ensure that the room in which the system will operate has adequate air circulation.
- Allow (at least 1M, 3.28 feet) clearance for door opening.
- Allow (at least 1M, 3.28 feet) clearance on the top of the UPS, to assure heat dissipation is ventilated through the openings.
- Do not locate the system near machinery which produces metallic dust or powder, or any facility that will produce corrosive substances or vapor.



Caution: Always follow proper ESD-prevention procedures to avoid damage to equipment. Damage from static discharge can cause immediate or intermittent equipment failure.

4.2.1 Recommended Facility Protective Device Ratings, BTU/HR, & Floor Loading.

UPS RATING	Input Volt.	Output Volt.	Unit Input Circuit Breaker (Amps)	Recommended Facility Input Circuit Breaker Over Current Protection (Amps)	Unit Output Circuit Breaker (Amps)	Recommended Facility Output Circuit Breaker Over Current Protection (Amps)	Batt. Volt	BTU/HR, Fast Transfer, Green Mode (Typ)	UPS Cabinet Weight lbs. (Approx.)	Floor Loading LB/SQFT (Approx.)	UPS CAB. DIM W x H x D		
30KVA /24KW	208/120V	208/120V	125Amps	Recommended Facility Input Circuit Breaker Should Be Equal to or Larger Than the Unit Input Circuit Breaker Ampacity	100Amps	Recommended Facility Output Circuit Breaker Should Not Be Larger Than the Unit Output Circuit Breaker Ampacity	348	7720	1260	170	34 x 75 x 31.5		
	480/277V	480/277V	60Amps		60Amps			7720	1260	170			
40KVA /32KW	208/120V	208/120V	175Amps		150Amps			8931	1414	190			
	480/277V	480/277V	80Amps		60Amps			8931	1414	190			
50KVA /40KW	208/120V	208/120V	200Amps		175Amps			11164	1525	205			
	480/277V	480/277V	100Amps		80Amps			11164	1525	205			
60KVA /50KW	208/120V	208/120V	250Amps		200Amps			13197	1724	232			
	480/277V	480/277V	100Amps		100Amps			13197	1724	232			
80KVA /64KW	208/120V	208/120V	300Amps		300Amps			17863	2276	187			
	480/277V	480/277V	150Amps		125Amps			17863	2276	187			
100KVA /80KW	208/120V	208/120V	400Amps		400Amps			22329	2984	246			
	480/277V	480/277V	175Amps		150Amps			22329	2984	246			
120KVA /96KW	208/120V	208/120V	600Amps		400Amps			22795	3138	258			
	480/277V	480/277V	225Amps		200Amps			22795	3138	258			
160KVA /128KW	208/120V	208/120V	800Amps		600Amps			30393	3868	319			
	480/277V	480/277V	400Amps		250Amps			30393	3868	319			
200KVA /160KW	208/120V	208/120V	800Amps		800Amps			Consult Factory					
	480/277V	480/277V	400Amps		300Amps								
240KVA /192KW	208/120V	208/120V	1000Amps		800Amps								
	480/277V	480/277V	600Amps		400Amps								
300KVA /240KW	208/120V	208/120V	1200Amps	1000Amps									
	480/277V	480/277V	600Amps	600Amps									

Note: For all wire sizes consult local codes and NEC based on unit current requirements
 For each system battery cabinet dimension and weight refer to Appendix A - Battery Connections

Table 4-1 Operating Environment

The location you choose for the installation should confirm to the following conditions.

Table -4-2 Inverter Environmental Specifications

Inverter Environment	Description
Ambient temperature:	0° to 40°C (32°F to 104°F)
Relative humidity:	0% to 90% (non-condensing)
Operating altitude:	Less than 1500 meter (5000 feet) Above Sea level
Audible Noise	< 65 dB at 1 meter (3.28 feet)

For optimal performance and reliability, and to prolong lifetime, it is recommended to keep the environment temperature below 25°C, and humidity below 80%.



For optimal performance and reliability, and to prolong lifetime, it is recommended to keep the environment temperature below 25°C, and humidity below 80%.

Table -4-3 Battery Environmental Specifications

Battery Cabinet Environment	Description
Ambient temperature:	22° to 25°C (72° to 77 °F)
Relative humidity:	0% to 90% (non-condensing)
Operating altitude:	Less than 1500 meter (5000 feet) Above Sea level



Caution: Operating batteries outside of the specifications shown above will shorten battery life significantly.

4.2.2 Floor Load Ratings

The floor space at the installation site must be strong enough to support the combined weight of the Lighting Inverter unit and all battery cabinets. To ensure adequate load-bearing capacity, plan for the maximum configuration.

4.3 Delivery and Handling

4.3.1 Inspecting the Shipment

The equipment included in your shipment consists of one Lighting Inverter cabinet. Batteries will typically ship separately unless specified otherwise. The contents are covered with protective wrapping and packaged in heavy-duty cardboard. Each item is labeled with the component name for easy identification.

When the equipment arrives, count the number of items delivered to ensure that you have the complete shipment. Inspect all protective wrapping or crates and any boxes for signs of rough handling or damage, such as punctures and crushed sides, preferably without moving the equipment. If the shipping container or equipment itself shows evidence of damage, record the damage on the receiving document before signing for receipt of the equipment. Damage claims should be filed directly with the carrier.

Thoroughly inspect each battery for any signs of damage. If there is any damage, reject the shipment and notify the manufacturer by email services@800pwrsrvc.com. If possible, photograph the damage for future reference. As you unpack the pallet or container, check each battery box for damage on all sides, the top and bottom. If there is any sign of damage, photograph the damage if possible, and email services@800pwrsrvc.com.

Offloading the System

Because the system is designed for pad mounting, it is not accompanied by casters. At the user's discretion, a forklift can be used to off load the unit from the shipping pallet. Always be sure that the load capacity of the forklift is sufficient to support the weight of the unit and its battery cabinets.



DANGER: Exercise extreme care when handling the cabinets to avoid equipment damage or injury to personnel. Each cabinet weighs several hundred pounds. Test lift and balance the cabinets before moving. Maintain minimum tilt from vertical at all times. The bottom structure will support the unit only if the forklift forks are completely underneath the unit.

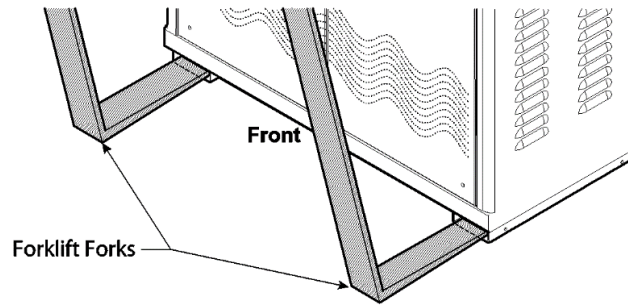

4.3.2 Climatization

Units that are shipped or stored at extreme temperatures require time to adjust to operating temperatures before startup. If the unit arrives in hot or cold weather, do not unpack it until it has been allowed to reach room temperature (one to two hours).

Immediately exposing the unit to warm temperature can cause condensation to occur, which could damage the electronics. If you notice any condensation, allow the unit to stand unattended for one to two hours, and then unpack it.

4.3.3 Unpacking the Equipment

After checking the cartons for signs of damage, perform the following steps to unpack the equipment:

1. Open all cartons.
2. Compare the items received to the packing list. If an item is missing or damaged, contact your place of purchase.
3. Remove all packing materials, envelopes, and boxes from the cartons. Please keep all packing materials and cartons in case you need to transport or ship the unit.
4. Determine which knockouts will be used (for Battery Cabinet) to route cables into and out of the unit. Remove only the conduit knockouts that are to be used.

In addition to the contents supplied with the unit, the user must supply a fork lift to perform the installation.

4.3.4 Cabling and Mounting

The top of the unit conduit plate for running cables, See Figure 4.1, Figure 4.2 , Figure 4.4 for location.

Remove the predrilled conduit knockouts on top and side for battery cabinet(s)



NOTE: Drill holes that will be used for conduit on the knockout plates for the UPS and knock out only the ones to be used on battery cabinet. Do not drill

holes other than these without first consulting the factory by emailing service@800pwrsrv.com our engineers will assist you in locating the conduit to maintain unit reliability.

5. Measure the locations for the conduits on the conduit plate.
6. Punch holes in the conduit plates or knockouts for Battery Cabinet(s).
7. Anchor the cabinet to the mounting pad at the mounting locations.
8. Anchor the conduits to the conduit knockouts.

4.3.5 Electrical Connections

The following sections describe how to perform the electrical connections. In these sections, “TB” refers to terminal block. Before making electrical connections, observe the following:



DANGER: Verify that all customer-supplied wiring is de-energized before performing any electrical work. Failure to do so could result in electrocution, injury, or damage to equipment.



DANGER: Even when the unit is off, there are potentially dangerous voltages within the unit due to the batteries. Exercise extreme care when working within the enclosure to avoid the possibility of electrocution, injury or damage to the equipment.

Table 4-4

Terminal Block wire range for each KVA and Voltage (480Y/277V input, 480Y/277V Out)				
Rating	24KW	32KW	40KW	50KW
Input	20 AWG – 6 AWG	20 AWG – 6 AWG	1/O – 6 AWG	2 AWG – 12 AWG
Output	20 AWG – 6 AWG	20 AWG – 6 AWG	1/O – 6 AWG	2 AWG – 12 AWG
DC	1/O – 12 AWG	1/O – 6 AWG	4/O – 2 AWG	4/O – 2 AWG
Rating	64KW	80KW	96KW	128KW
Input	1/O – 6 AWG	4/O – 2 AWG	4/O – 2 AWG	500 – 300kcmil
Output	1/O – 6 AWG	1/O – 6 AWG	4/O – 2 AWG	300 – 2 AWG
DC	300 – 2 AWG	500 – 4 AWG	2 X (500 – 4 AWG)	2 X (500 – 2 AWG)

Terminal Block wire range for each KVA and Voltage (208Y/120V input, 208Y/120V Out)				
Rating	24KW	32KW	40KW	50KW
Input	1/O – 12 AWG	1/O – 12 AWG	4/O – 2 AWG	300 – 2 AWG
Output	1/O – 12 AWG	1/O – 12 AWG	1/O – 6 AWG	4/O – 2 AWG

Terminal Block wire range for each KVA and Voltage (480Y/277V input, 480Y/277V Out)				
DC	1/O – 12 AWG	1/O – 6 AWG	4/O – 2 AWG	4/O – 2 AWG
Rating	64KW	80KW	96KW	128KW
Input	500 – 300kcmil	500 – 300kcmil	2 X (500 – 4 AWG)	2 X (750kcmil)
Output	300 – 2 AWG	500 – 300kcmil	2 X (4/O – 6 AWG)	2 X (750kcmil)
DC	300 – 2 AWG	500 – 4 AWG	2 X (500 – 4 AWG)	2 X (500 – 2 AWG)

NEED VERBAGE FOR CUSTOMER CONNECTION

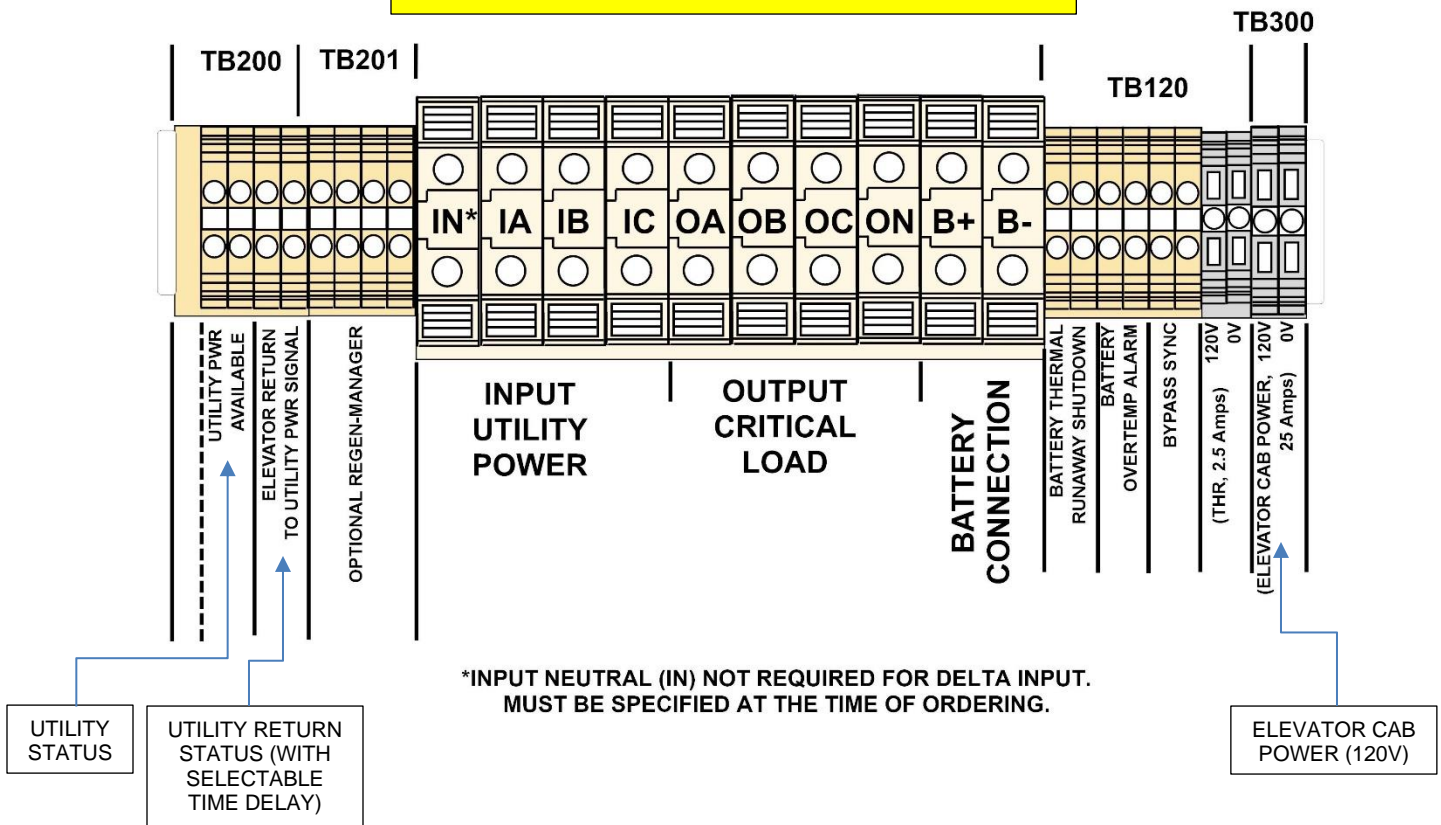

Figure 4.8 Customer Connections to the Input / Output / Battery (DC) Terminal Block (typical)



Note: The Input/Output/Battery terminal connect shown is typical and might be different than actual unit. Refer to each unit label configuration for connection.



Caution: For system with customer KAIC rating refer to section B.7

4.3.6 Output Load Connections

1. Connect the critical load to output terminal blocks, as shown in Figure 3.2 (without any sub-feed circuit breakers).
2. If there are any sub-feed circuit breakers being used, then connect the critical load directly to the sub-feed breakers. See figure 3.2 with optional sub-feed breakers.

4.3.7 Battery Connections

For information about specific battery connections, refer to the battery connection diagram for each sales order.



Caution: Ensure that the DWG NO of the system matches the DWG NO on the nameplate. See Figure 4.9 Typical Nameplate.

NAME
UPS CABINET
SERIAL NO.: _____ MODEL NO.: _____ MFG DATE: _____
RATING: _____ FREQUENCY: _____ INPUT VOLTAGE: _____ INPUT CURRENT: _____ OUTPUT VOLTAGE: _____ OUTPUT CURRENT: _____ DC VOLTS: _____ BATTERY CURRENT: _____
 Intertek 94155 CONFORMS TO : UL 924 LIGHTING INVERTER ALL VALUES ARE NOMINAL 1225-1889-XXX REV. XX

Figure 4.9 Typical Nameplate

4.3.8 Storing the System

If you will not be using the system as soon as you receive it, keep it in its original packing material and store it in an indoor environment that meets the following conditions.

Specification	Description
Ambient temperature:	-20° to 70°C (-4° to 158°F)
Relative humidity:	0% to 95% (non-condensing)



NOTE: After unpacking and before turn-on:

Use plastic cover provided in the pouch on the front door to cover the unit during installation and while waiting for turn on, to prevent dust, construction debris and any other foreign object entering the unit.

Accumulation of dust and debris on all electronics will cause damage which will not be covered by warranty.

4.3.9 Recharging Batteries During Storage

If the unit will be stored for three months or longer, visually inspect, and charge the batteries for 24 hours at regular, three-month intervals, refer to the battery label for battery voltage and use appropriate charger.

Chapter 5. Operation

Topics:

- ▲ *Starting the Unit for the First Time (page 53)*
- ▲ *Shut-down Procedure (page 55)*
- ▲ *From Inverter to Maintenance Bypass Procedure (page 56)*
- ▲ *From Maintenance Bypass to Inverter Procedure (page 56)*
- ▲ *LCD Display (page 57)*
- ▲ *Front Panel (page 67)*

This chapter describes how to operate the unit.

5.1 Starting the Unit for the First Time

Initial start-up of the unit **must be performed by factory certified personnel** or an authorized representative. To request start-up:

1. Download the Request for Turn-On form (6002-1545) from www.800pwrsrv.com.
2. Either complete the form online and email it to service@800pwrsrv.com or fax a printed copy to Power Services at (323) 721-3929.

The following procedure describes the initial start-up. Do not start up the unit without the assistance of factory-trained and authorized personnel; otherwise, you might damage the unit and void the unit warranty.

3. Verify that there is no power coming to the unit by checking the facility, main input battery, and output circuit breaker(s), they should all be in OFF position.
4. Verify the batteries are installed and torqued in accordance with the battery connection diagram provided with the unit inside the front door pocket.
5. Confirm that all cable connections are secured firmly.



Caution: If anything, unusual occurs during the start-up procedure, turn off the input circuit breaker immediately and email service@800pwrsrv.com or contact (800) 797-7782 for technical assistance.

6. Apply input power to the unit.
7. Close the Input circuit breaker.
8. Close the Reserve circuit breaker. The reserve and output LED on the mimic panel will light up, indicating the reserve static switch loop is energized. There is power on the output now. The supply of power in the Unit is established and the fans will operate.
9. Close the rectifier breaker - The rectifier will automatically start if the power source is correctly connected. Wait 30 sec for DC bus voltage to rise until the warning LEDs of "BAT LOW" and "BAT LOW STOP" go off (on the front panel). Now, the DC is already ready for the inverter.
10. Close the battery breaker. Now the batteries will take over to supply the DC bus if rectifier mains fail.
11. Verify that the voltage measured on the input circuit breaker is 208Y/120V or 480Y/277 VAC and is the same as the nameplate voltage rating. If the voltage is not the same as on nameplate within +10% to -15% tolerance, email service@800pwrsrc.com or call (800) 797-7782 for technical assistance before proceeding.

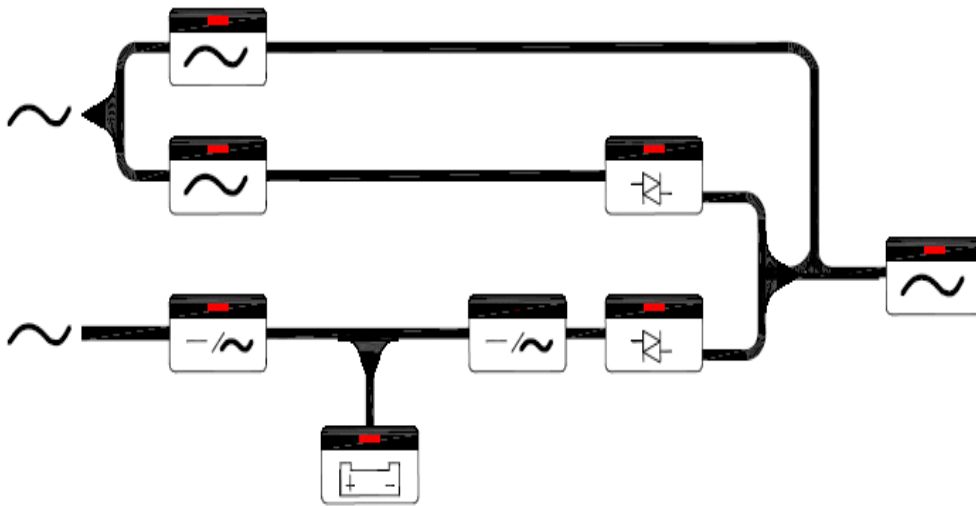

Figure 5.1 Mimic Display under normal operation

12. Push inverter ON switch – To turn on the inverter, the inverter ON switch (I) and the control switch (◆) must be pressed simultaneously. The inverter will start working and the inverter output will be established in 4 seconds. The load will automatically be transferred to the inverter 3 seconds later. Now the unit is in normal operation.
13. Check if the mimic LED is correct, as shown in [Figure 5.1](#). All warning LEDs on the right side are off, two LEDs: 'INVERTER ON' and 'INVERTER SS' on the left side should be lit. If the load is over 70%, the '70% LOAD' LED will also be lit.
- 14.



This concludes the start-up procedures. The load should be as balanced as possible on each phase.

5.2 Shut-down Procedure

If you want to shut-down the Unit completely (no power at output or inside), follow the steps below.

1. Switch off the inverter. The inverter can be switched off by pressing the inverter OFF switch (O) and the control switch (◆) simultaneously. The load will be automatically transferred to reserve without interruption.
2. Open the Battery breaker – If you want to shut-down all the power of the Unit, continue to open the battery breaker. Now the DC bus is only supported by the rectifier.
3. Open the Rectifier breaker, Opening the rectifier breaker will further take the power source away from the DC bus, and the DC bus will start to drop slowly. After 5 minutes, the DC bus will drop to a safe level (< 20VDC).
4. Open the Reserve breaker.



Caution: Before opening the reserve breaker, ensure there are no critical loads connected to the output.

5. After opening the reserve breaker, there will be no power to the output (or load).
6. Open Input circuit breaker.
7. At this point, all power to the unit has been cut off and none of the LEDs or LCDs are lit. The UPS now is completely shut off.



This concludes the Shut-down procedures.

5.3 From Inverter to Maintenance Bypass Procedure

If you want to Shut-off the unit for maintenance without disconnecting the power supply to the critical, follow the steps below.

8. Switch off the inverter – The inverter can be switched off by pressing the inverter OFF switch (⊙) and the control switch (◀▶) simultaneously. The load will be automatically transferred to reserve without interruption.
9. Open the Battery circuit breaker, you have to shut-down the power inside the Unit. Therefore, continue to open the battery breaker.
10. Open the rectifier breaker – Opening the rectifier breaker will take the power source away from the DC bus, causing the DC bus to drop slowly. After 5 min., the DC bus will drop to a safe level (<20VDC).
11. Close the bypass breaker – The reserve breaker and reserve static switch are still conducting. Therefore, when the maintenance bypass breaker is closed, power will flow through the bypass loop instead of the reserve loop because of the lower impedance of bypass loop.
12. Open the reserve breaker, you can now open the reserve breaker to disconnect the UPS from any power supply.

5.4 From Maintenance Bypass to Inverter Procedure

If the UPS is in maintenance bypass mode, and you want to turn the unit to normal mode without interrupting the output AC, please follow the steps below.

1. Close the reserve breaker – The reserve and output LED on the mimic will light, indicating the reserve static switch loop is energized, and the output has power. The power supply in the unit is also established, and the fans will operate.
2. Open the bypass breaker – The inverter cannot be switched on while the maintenance bypass breaker is closed (because the CPU will sense the breaker and prevent the inverter from connecting directly to AC source). Since the reserve breaker is already closed, power goes through the reserve loop if the bypass breaker is open. Thus, AC at the output will not be interrupted.
3. Close the rectifier breaker, the rectifier will be automatically started if the power source is connected correctly. Wait 30 sec for DC bus voltage to rise until the warning LEDs of “BAT LOW” and “BAT LOW STOP” go off (on the front panel). Now, the DC is already ready for the inverter.
4. Close the Battery breaker, Now the battery will take-over to supply the DC bus if the rectifier mains fail.
5. Push inverter ON switch – To turn on the inverter, the inverter ON switch (■) and the control switch (◀▶) must be pressed simultaneously. The inverter will start working and inverter output will be established in 4 seconds. The load will automatically be transferred to the inverter 3 seconds later. Now the UPS is in normal operation.

5.5 LCD Display

The LCD can display much more information than can the LEDs. In order to make the display sharp and readable, the LCD is back-lighted by LEDs. But to further prolong the life of the LEDs, the CPU will cut off power to the LEDs 3 minutes after the last keystroke of UP, DOWN or ENTER is pressed. The backlighting will resume if the UP, DOWN or ENTER key is subsequently pressed. Page displays of the LCD are described below. This screen will refresh once the system power is enabled (i.e. the default screen).

- Menu 0 – Main Menu

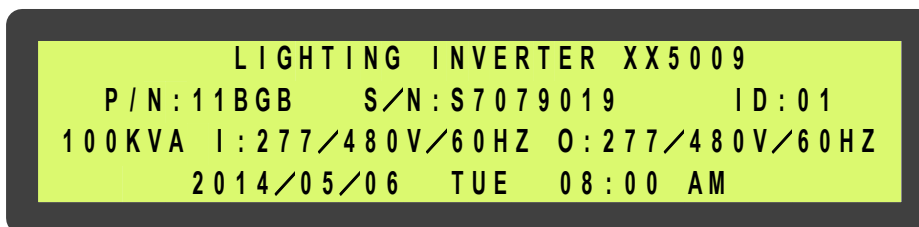

The first row will display the greeting text set by the factory. Changing the text of this row is not recommended. The parameter no. (P/N), serial number (S/N), and the identification number (ID) are displayed in the second row. While the third row will display the KVA rating, input rating and output rating of the UPS. Changing the parameter number of the second row will also change the rating displayed in the

second row (rating is automatically generated by CPU inside the UPS according to the P/N number).



Caution: Never change the parameter number yourself, because some parameters will be changed accordingly.

Serial number is set by factory for the convenience of maintenance personnel who may need to refer to the serial number of the unit serviced. The identification number is set only when an external control module is connected to more than one system. Each UPS must have a unique number to identify itself, and it should be set by installation technical personnel after installation. The YEAR/MONTH/DATE, DAY OF THE WEEK, HOUR: MINUTE and AM (PM), from the real time clock inside the UPS, are displayed in the fourth row for user's reference and date/time stamping in the historical data when abnormal conditions occur. Pressing one of the UP, DOWN or ENTER keys will change the LCD to the MENU 1 screen.

❑ Menu 1 – Select Menu

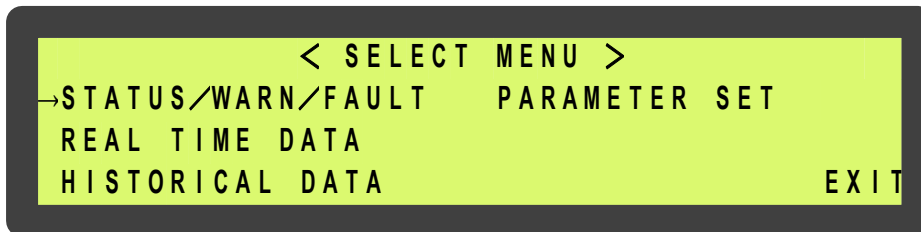

❑

The Select Menu is for the user to select, via the cursor (→), the type of data the user wants to view, such as, inverter on/off, buzzer on/off, charging time and magnitude, date/time etc. The cursor (→) can be moved upward by the UP (↑) key and can be moved downward by the DOWN (↓) key. The selection is confirmed by pressing the ENTER key (↵), and change to the menu at which the cursor is pointing. If the item “PARAMETER SET” is selected, the LCD will jump into a screen which will ask the user to key in the password. See the figure below.

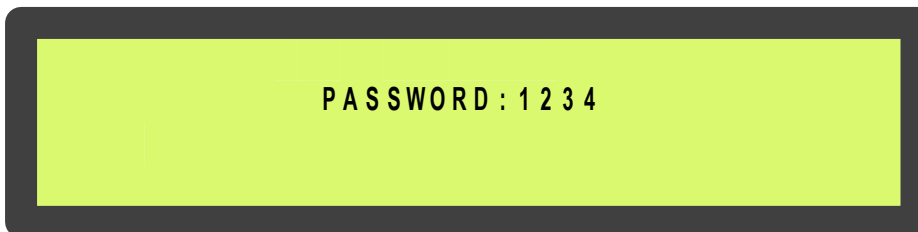

The password is a 4-digit number which can be changed upward or downward by the UP (↑) or the DOWN (↓) key and can be confirmed by the ENTER (↵) key. The selection will continue if the correct password is entered, or will go back to MENU 0, the MAIN MENU, if no correct password is entered after 3 trials. The password for entering the < PARAMETER SET > menu is 1-2-3-4. The entering of MENU 12, the OTHER SETTING menu, is permitted by another password, to be used by

maintenance personnel. Users can obtain this password from the manufacturer for user's maintenance technicians.



Note: If "EXIT" is selected (blinking instead of pointed by cursor), the screen will return to MENU 0.

☐ Menu 2 – Status / Warning Menu



This menu is displayed when STATUS/WARN/FAULT is selected from MENU 1. The left-hand side of this menu shows the real time status of the rectifier, inverter and static switch. The right-hand side shows the warning or fault conditions, if any. Therefore, under normal conditions, the LCD display should be exactly as shown above. When minor abnormal conditions occur, these will be shown under the title < WARNING >. These will be overridden by a fault message if more serious abnormal conditions occur, and the title < WARNING > will change to < FAULT >. For example, if short circuit occurs at the output, this screen will display the following:

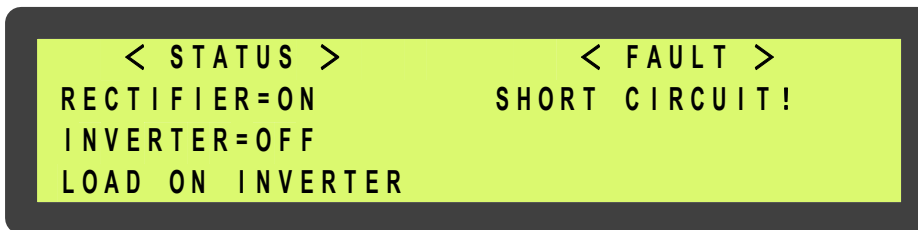

The inverter should be shut off under a short circuit condition. Since the CPU will detect a short circuit, and in order to avoid unnecessary tripping and damage to the breaker, the static switch remains connected to the inverter (will not transfer to reserve).

Listed below are all the warning conditions that can be displayed (arranged in order of priority, starting with the highest priority):

Row	Display			
1st row	Bypass ON	Rect AC Fail	Rectifier Phase Error	Reserve Freq. Error
2nd row	170% Overload	150% Overload	125% Overload	110% Overload
3rd row	Battery Low Stop	Battery Bad	Battery GND Fault	Battery Setting

Lists below are all the fault conditions that can be displayed:

Row	Display
1st row	High DC Shutdown

Operation

2nd row	Short Circuit	Fuse/Overheat	Overload Shutdown	Emergency Stop (if applies)	Inverter Abnormal
3rd row	Bypass Shutdown				

The UP (↑) or DOWN (↓) key has no function in this menu. The screen will go back to MENU 1 – the SELECT menu, when ENTER (↵) is pressed.

❑ Menu 3 – Real Time Data Menu

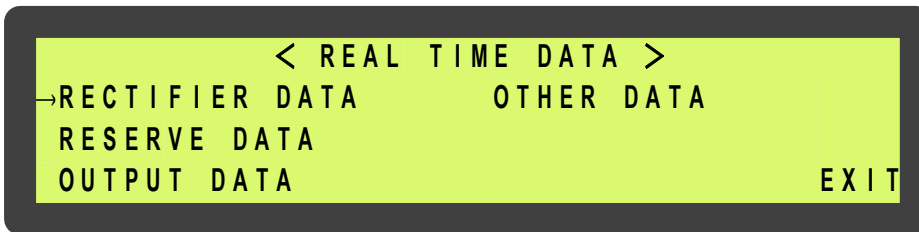

❑

This menu is displayed when the REAL TIME DATA is selected from MENU 1. The cursor (→) is used to select the type of real time data the user wants to view, such as, RECTIFIER DATA, RESERVE DATA, OUTPUT DATA, OTHER DATA etc. The cursor (→) can be moved upward by the UP (↑) key and can be moved downward by the DOWN (↓) key. The selection is confirmed by pressing the ENTER (↵), changing the menu to that at which the cursor is pointing.

If “EXIT” is selected (blinking instead of pointed by cursor), the screen will go back to the MENU 1- the SELECT MENU.

❑ Menu 4 – Historical Event Menu

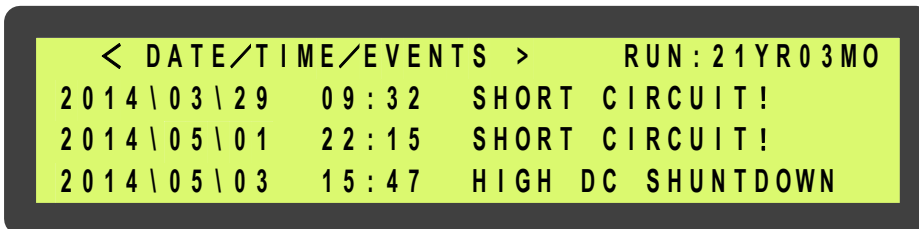

❑

This menu is displayed when HISTORICAL DATA is selected from MENU 1. The records stored in EEPROM when abnormal events occur are displayed in this menu. The record display starts with the date/ time stamp of the abnormal condition, making it possible for the user or maintenance personnel to trace the occurrence. Seventy-seven (77) records can be stored in one EEPROM, which can be increased to 154 records with a second EEPROM. These records will not be erased by cutting off of the power supply or complete shutdown of the ELI, i.e., they will be kept in EEPROM until overwritten by the 78th (or the 155th) record.

Three records can be displayed concurrently on the screen. The records displayed (once this menu is opened) are the three most recent records in the EEPROM. The displayed records will move one record upward when the UP (↑) key is pressed and move one record downward when the DOWN (↓) key is pressed.

The abnormal conditions that can be displayed are listed below:

- HIGH DC SHUTDOWN
- SHORT CIRCUIT
- FUSE/OVERHEAT
- OVERLOAD SHUTDOWN
- EMERGENCY STOP (if applicable)
- INVERTER ABNORMAL BYPASS ON SHUTDOWN

Also, in the top right corner the screen, the UPS run time is displayed in year/month for the reference of the user or maintenance personnel. This can be used to estimate recurring maintenance intervals.

The screen will go back to MENU 1- SELECT MENU by pressing the ENTER (↵) key.

☐ Menu 5 – Parameter Setting Menu

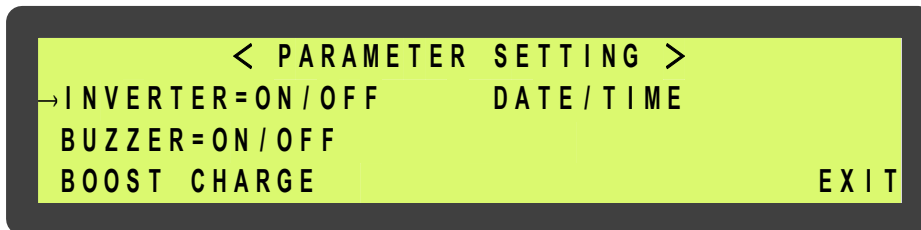

☐ This menu is displayed when < PARAMETER SET > is selected from MENU 1, and the correct password has been entered. The cursor (→) is used to select the parameter the user wants to set, e.g., INVERTER ON/OFF, BUZZER ON/OFF, BOOST CHARGE, DATE/TIME etc. The cursor (→) can be moved upward by the UP (↑) key and can be moved downward by the DOWN (↓) key. The selection is confirmed by pressing the ENTER (↵) key.

The first item that can be set is the INVERTER ON/OFF. When this is selected, “INVERTER ON/OFF” will be displayed, where the “ON” will blink if the inverter status is on, and the “OFF” will blink if the inverter status is off. The intended status can be changed by UP (↑) or DOWN (↓) key and is confirmed by ENTER (↵) key. Then “INVERTER = ON” will be displayed if “ON” is selected or “INVERTER = OFF” will be displayed if “OFF” is selected, the UPS will switch the inverter on or off according to the selection.

The second item that can be set is the BUZZER ON/OFF. When selected, “BUZZER ON/OFF” will be displayed, where the “ON” will blink if the buzzer status is on, and the “OFF” will blink if the buzzer status is off. The intended status can be changed by UP (↑) or DOWN (↓) key and is confirmed by ENTER (↵) key. Then “BUZZER = ON” will be displayed if “ON” is selected or “BUZZER = OFF” will be displayed if “OFF” is selected, and the unit will switch on or off the buzzer according to your selection.

The third item that can be set is the BOOST CHARGE. When this is selected, the screen will jump to MENU 10, the BOOST CHARGE SETTING MENU (the setting method will be explained later).

The fourth item that can be set is the DATE/TIME. When this is selected, the screen will jump to MENU 11, the DATE TIME SETTING MENU (the setting method will be explained later).

If “EXIT” is selected (blinking instead of pointed by cursor), the screen will go back to the MENU 1- the SELECT MENU.

❑ Menu 6 – Rectifier Data Menu

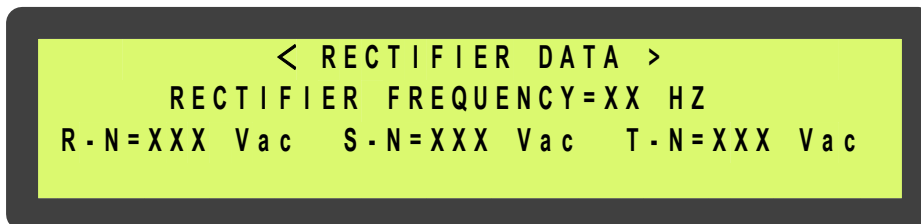

❑

This menu is displayed when <RECTIFIER DATA> is selected from MENU 3 – the REAL TIME DATA MENU. It is a data display menu which shows real time data on the rectifier, such as, RECTIFIER FREQUENCY, R-N/S-N/T-N VOLTAGE, etc. The phase to phase voltage display is also available when input is a delta (Δ) connected source.

The UP (\uparrow) or DOWN (\downarrow) keys have no function in this menu. The screen will go back to MENU 3 – the REAL TIME DATA menu, when ENTER (\leftarrow) is pressed.

❑ Menu 7 – Output Data Menu

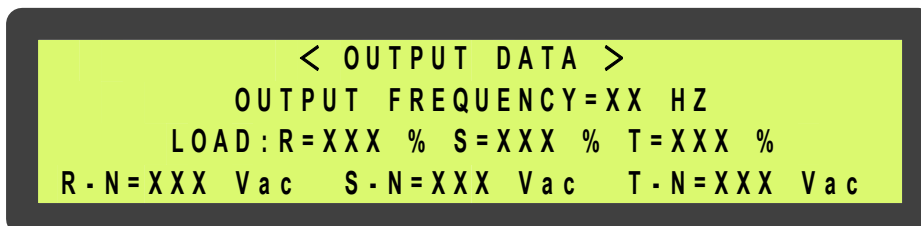

❑

This menu is displayed when <OUTPUT DATA> is selected from MENU 3 – the REAL TIME DATA MENU. It is a data display menu, which shows real time data on the output and load, such as, OUTPUT FREQUENCY, LOAD % OF R/S/T, OUTPUT R-N/S-N/T-N VOLTAGE, etc. The phase to phase voltage display is also available when input is a delta (Δ) connected source.

The UP (\uparrow) or DOWN (\downarrow) keys have no function in this menu. The screen will go back to MENU 3 – the REAL TIME DATA menu, when ENTER (\leftarrow) is pressed.

❑ Menu 8 – Other Data Menu

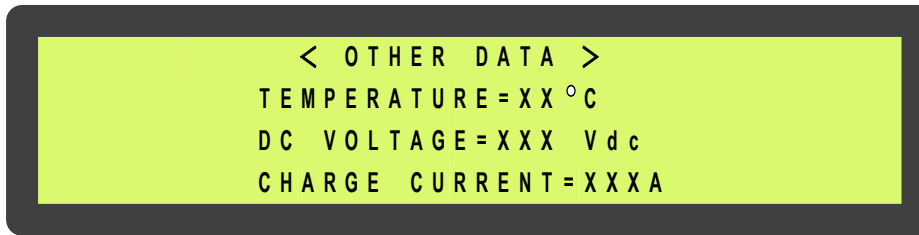

This menu is displayed when <OTHER DATA> is selected from MENU 3 – the REAL TIME DATA MENU. It is a data display menu, which shows real time data on the UPS, such as, TEMPERATURE, DC VOLTAGE, CHARGE OR DISCHARGE CURRENT etc. If the UPS is in normal operation mode, the data in the last row is the charging current of the batteries. The label is “CHARGE CURRENT =” (see the figure shown above). If the unit is in back-up mode, the data in the last row will be the discharging current of the batteries, and the title will be “DISCHARGE CURRENT =” (see the figure shown below)

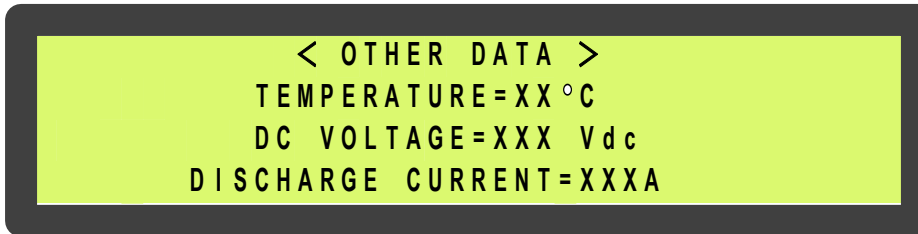

The UP (↑) or DOWN (↓) keys have no function in this menu. The screen will go back to MENU 3 – the REAL TIME DATA menu, when ENTER (↵) is pressed.

❑ Menu 9 – Reserve Data Menu

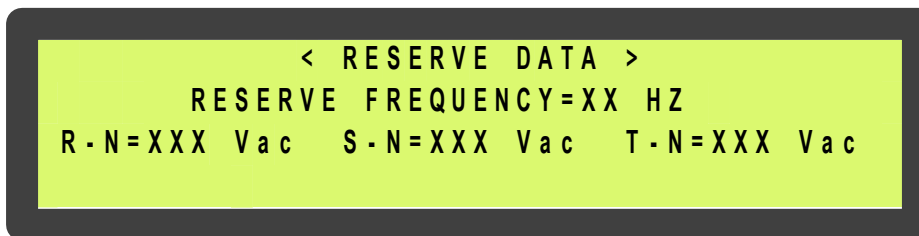

This menu is displayed when <RESERVE DATA> is selected from MENU 3 – the REAL TIME DATA MENU. It is a data display menu, which shows real time data of the reserve input, such as, RESERVE FREQUENCY, R-N/S-N/T-N VOLTAGE, etc., for the user’s reference. The phase to phase voltage display is also available when reserve input is a delta (Δ) connected source.

The UP (↑) or DOWN (↓) keys have no function in this menu. The screen will go back to MENU 3 – the REAL TIME DATA menu, when ENTER (↵) is pressed.

❑ Menu 10 – Boost Charge Setting Menu

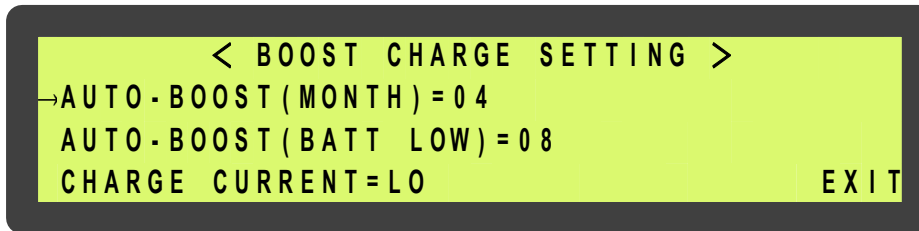

❑ This menu is displayed when the item < BOOST CHARGE > is selected from MENU 5, the PARAMETER SETTING menu. The user can change the charger parameters through this menu. The cursor (→) can be moved upward by the UP (↑) key and can be moved downward by the DOWN (↓) key. The selection is confirmed by pressing the ENTER (↵) key. See in the above figure.

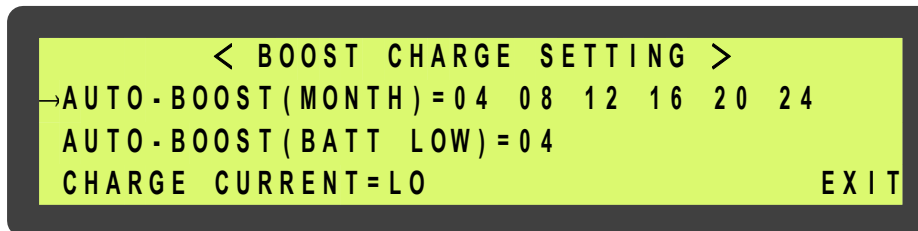

When AUTO-BOOST (MONTH) is selected, all the values that can be selected will be shown (04/08/12/16/20/24). The battery will be boost charged once every month. The boost charge time is set by this row, with the values being “hours”. The current value (or the value being selected) will flash and is confirmed by the ENTER (↵) key. Longer times are selected for bigger batteries according to the needs of the user. Refer to the figure above.

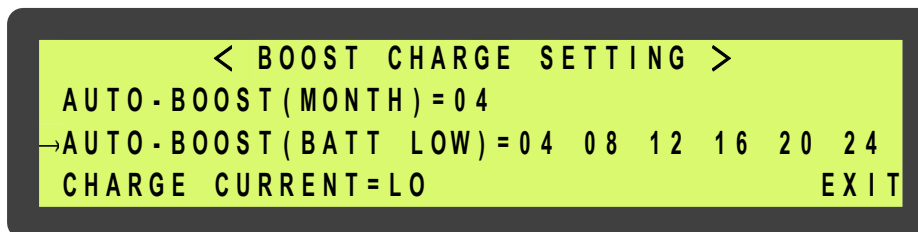

When AUTO-BOOST (BATT LOW) is selected, all the value that can be selected will be shown (04/08/12/16/20/24). The battery will be boost charged every time the battery has been discharged to below 12V/battery or 2V/cell. The boost charge time is set by this row, with the values being “hours”. The current value (or the value being selected) will flash and is confirmed by the ENTER (↵) key. Longer times are selected for bigger batteries according to the need of the user. See the figure above.

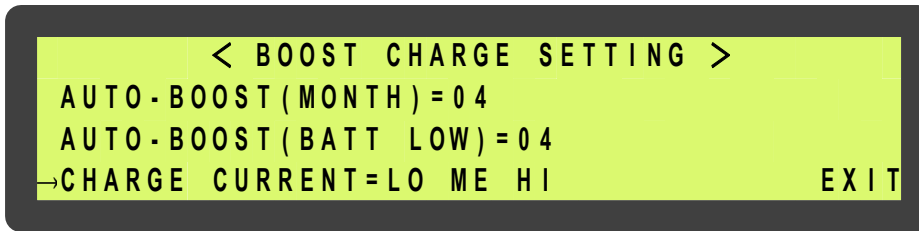

When CHARGE CURRENT is selected, the values that can be selected will be shown (LO/ME/HI). When the batteries are being boost-charged for whatever the reason, the charging current will be limited by a value according the setting in this row. The current value (or the being selected) will flash and is confirmed by the ENTER (↵) key.

- The value can be selected by a per list below:

BACK-UP TIME	SETTING
10 – 30 MIN	LO
30MIN – 1HOUR	ME
> 1 HOUR	HI

If “EXIT” is selected (blinking instead of pointed by cursor), the screen will go back to the MENU 5- the PARAMETER SETTING menu.

- Menu 11 – Date/Time Setting Menu

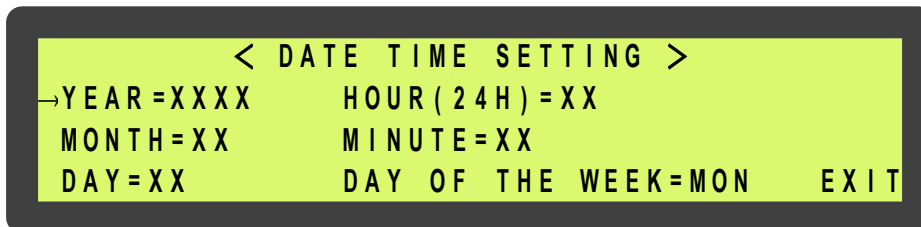

-

This menu is displayed when the item < DATE/TIME > is selected from MENU 5, the PARAMETER SETTING menu. The user can change the YEAR/MONTH/DAY/, HOUR/MINUTE/DAY OF THE WEEK of the real time clock through this menu. Once this menu is opened, the present value in the real time clock will be shown. The cursor (→) can be moved upward by the UP (↑) key and can be moved downward by the DOWN (↓) key to the item the user wants to change. The selection is confirmed by pressing the ENTER (↵) key. See the figure above. The values to be entered are numbers except the DAY OF THE WEEK (MON, TUE... provided for user selection). The values that can be entered are restricted to certain values according to which item is being set (the values are listed below).

Year	1998 – 2097
Month	01-12
Day	01 – 31
Hour	0 – 23

Minutes 0 - 59
Day of the Week Mon, Tue, Wed, Thu, Fri, Sat, Sun
Internal calendar will correct an error if 31 is entered to a 30
day month)

The value can be increased upward by the UP (↑) key and can be decreased downward by the DOWN (↓) key. The value will flash as it is being set. One can continue to push the UP (↑) or the DOWN (↓) key until the desired value is displayed. Again, the selection is confirmed by pressing the ENTER (↵) key. Thus, the values in the real clock will be changed according to the values entered.

If “EXIT” is selected (blinking instead of pointed by cursor), the screen will go back to the MENU 5- the PARAMETER SETTING menu.

☐ Menu 12 – Other Setting Menu

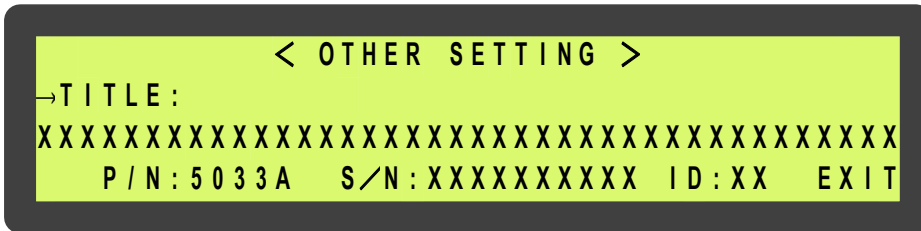

☐

This menu is displayed when the item PARAMETER SET is selected from MENU 1, the SELECT MENU and the correct password is entered. Note that this is a different password from the password used to enter PARAMETER SETTING menu, and should only be available to maintenance personnel. This menu can change the TITLE, P/N, S/N, ID etc. Once this menu is opened, the current value in the EEPROM will be shown. The cursor (→) can be moved upward by the UP (↑) key and can be moved downward by the DOWN (↓) key to the item one wants to change. The selection is confirmed by pressing the ENTER (↵) key.

See the figure above. Once either one of the items is selected, the values of that item are cleared; now waiting for new values to be entered. The values to be entered are either alpha or numeric, except the ID for which only numbers are allowed. The values that can be entered are restricted to certain values according to which item is being set (the values are listed below).

- Title ☐, A – Z, 0 - 9
- P/N ☐, A – Z, 0 - 9
- S/N ☐, A – Z, 0 - 9
- ID 0 - 31

** where ☐ means blank

If “EXIT” is selected (blinking instead of pointed by cursor), the screen will go back to the MENU 5, the PARAMETER SETTING menu.

5.6 Front Panel

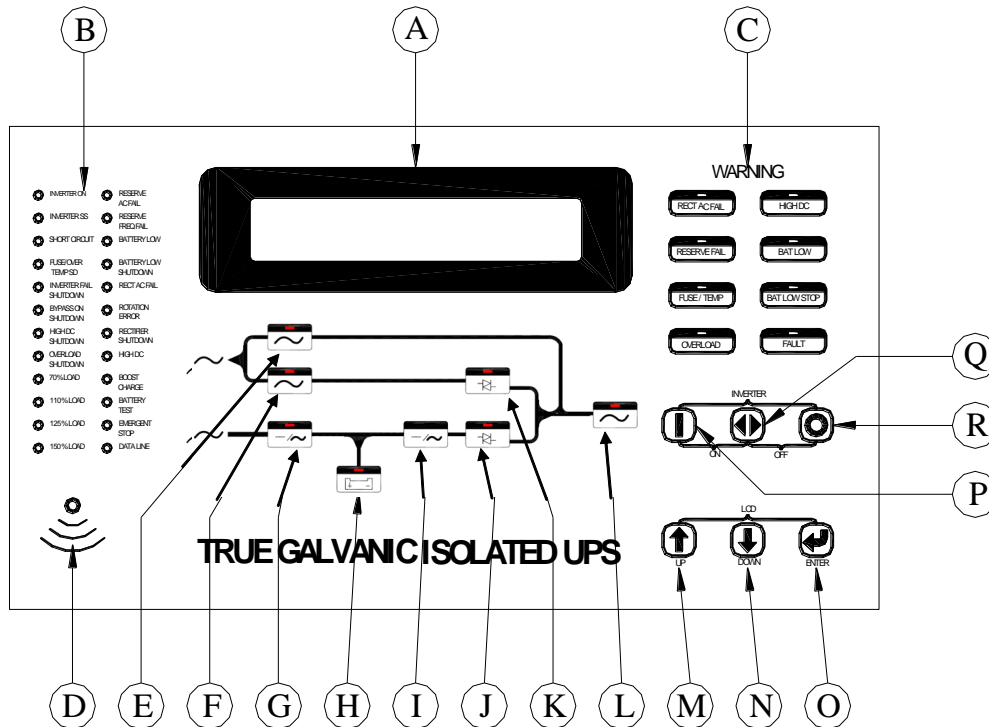

The front panel is located at the front of the PCB holder. It gathers the real time information of the system and shows them clearly to the user. It also provides switches for controlling and setting the unit. Through this panel, the UPS can be not only a stand-alone machine supplying the load, but also closely monitored by the user. Each part of the panel is explained below.

A. LCD display:

Real time status, data or historical events are displayed on the LCD. The UPS parameters, real time clock, inverter, and buzzer also can be set through this LCD. The LCD is back-lighted by LEDs to provide a sharp display. In order to lengthen the LED's life time, the LED are automatically shut off 3 minutes after no key is activated but will light up again when one of the up/down/enter keys is pushed.

B. Status LEDs:

24 LEDs, representing all of the important information of the UPS, provide the most up to date information to the user. Therefore, these LEDs are especially important when abnormal conditions occur. The 24 information items are as shown below:

- **INVERTER ON** – inverter is running.
- **INVERTER SS** – inverter static switch conducts while the reserve static switch is opened.
- **SHORT CIRCUIT** – UPS output is in short circuit state.
- **FUSE/OVER TEMP SD** – inverter shutdown due to either fuse broken or over temperature condition.
- **INVERTER FAIL SHUTDOWN** – inverter shutdown due to inverter output voltage too low.
- **BYPASS ON SHUTDOWN** – inverter shutdown due to bypass breaker being closed while the inverter is running.
- **HIGH DC SHUTDOWN** – inverter shutdown due to overly high DC bus voltage condition while the inverter is running.
- **OVERLOAD SHUTDOWN** – inverter shutdown due to overload of the inverter for a period over that which the inverter can endure; will restart 7 seconds after overload removed.
- **70% LOAD** – load connected to the output is at or over 70% of the system rating.
- **110% LOAD** – load connected to the output is over 110% of the system rating.
- **125% LOAD** – load connected to the output is over 125% of the system rating.
- **150% LOAD** – load connected to the output is over 150% of the system rating.
- **RESERVE AC FAIL** – reserve AC magnitude is out of range.
- **RESERVE FREQ FAIL** – reserve frequency is out of range.
- **BATTERY LOW** – DC bus (or battery) is lower than 320VDC, low battery shutdown is approaching.
- **BATTERY LOW SHUTDOWN** – inverter shutdown due to DC bus (or battery) lower than 295VDC (lower than the acceptable DC voltage of the inverter).
- **RECT AC FAIL** – rectifier AC magnitude is out of range.
- **ROTATION ERROR** – rectifier AC phase rotation is incorrect.
- **RECTIFIER SHUTDOWN** – rectifier shutdown due to DC bus too high (over 445VDC), will automatically restart 30 seconds after abnormal situation has been cleared.
- **HIGH DC** – DC voltage over 430VDC and the bus voltage will be limited at this voltage.
- **BOOST CHARGE** – the batteries are being boost charged by the rectifier.

- **BATTERY TEST** – batteries are being tested.
- **EMERGENCY STOP** – inverter shutdown due to emergency stop switch pushed.
- **DATA LINE** – blinks when data is transmitted to or received from the communication port.

C. Warning LEDs

When abnormal condition happens, these LEDs will light to warn the user according to the cause of the faulty condition. Therefore, all these LEDs should be extinguished under normal condition. These LEDs are as shown below:

- **RECT AC FAIL** – Rectifier AC input is abnormal either due to AC magnitude out of the range or phase rotation error, rectifier shutdown.
- **RESERVE FAIL** – reserve AC input is abnormal either due to AC magnitude out of range or frequency out of range.
- **FUSE/TEMP** – Inverter fuse is blown or over temperature condition exists.
- **OVERLOAD** – Output is overloaded by over 110%, 125% or 150%.
- **HIGH DC** – the LED will light as long as the DC voltage is over 430VDC.
- **BAT LOW** – the LED will light as long as the DC voltage is lower than 320VDC.
-
- **BAT LOW STOP** – the LED will light as long as the DC voltage is lower than 295VDC, inverter cannot start.
- **FAULT** – the inverter is shut down due to abnormal conditions such as overload, short circuit, high DC, fuse over temperature, bypass breaker on or emergency stop.

Since these LEDs are located behind the transparent window, the user can see them clearly without opening the door.

D. Audible (buzzer) alarm

When abnormal conditions occur, an audible sound should be emitted to warn the user to check the status of the unit. The alarm buzzer will beep under any one of the following conditions:

INVERTER IS OVERLOADED-

>110%, beep once / 3 seconds

>125%, beep once / second

>150%, beep twice / second

BACK- UP

>320VDC, beep once / 3 seconds

<320VDC, beep twice / second

<295VDC, no beeping

- **INVERTER IS SHORT CIRCUITED** - beep continuously
- **FUSE BROKEN** - beep continuously
- **HEAT SINK OVER TEMPERATURE** - beep continuously
- **HIGH DC SHUTDOWN** - beep continuously
- **BYPASS ON STOP** - beep continuously
- **EMERGENCY STOP** – (emergency power off) beep continuously



The buzzer will also beep once every time the inverter is switched on or off to acknowledge to the user that his key is valid and accepted.

E. Bypass LED

This LED will light when the maintenance bypass breaker is closed. When the maintenance bypass breaker is closed, the inverter cannot be switched on and will stop immediately even when inverter is already running.

F. Reserve LED

This LED will light when the reserve breaker is closed, and there is AC power supply present at the reserve terminal.

G. Rectifier LED

This LED will light when the rectifier is operating normally, meaning the rectifier Mains are within the range specified, the rotation sequence of three phases is correct, the rectifier breaker is closed, and no high DC voltage is on the bus.

H. Back-up LED

This LED will light when the UPS is in back-up mode. This is also as the indicator for battery test result. If the battery test does not pass, this LED will flash even if the UPS is not in back-up mode, to prompt the user to change the batteries.

I. Inverter LED

This LED will light when the inverter is switched on, indicating whether the inverter is running or not.

J. Inverter SS LED

This LED will light when the inverter static switch is turned on and the reserve static switch is turned off, i.e., the load is supplied from the inverter. Usually this LED will light 7 seconds after the inverter is switched on.

K. Reserve SS LED

This LED will light when the reserve static switch is turned on and the inverter static switch is turned off, i.e., the load is supplied from the reserve. Since the reserve static switch and inverter static switch will never both turn on simultaneously, the Inverter SS LED and the Reserve SS LED should never both be lit simultaneously.

L. Output LED

This LED will light when there is AC power present at the output terminal. This is an important indication for the user as to whether AC is available at the output or not.

M. Up key:

This is an LCD control key. It is for moving the cursor one item upward when items are being selected or for changing the number/character forward when data or parameter of the system is being set.

N. Down key:

This is an LCD control key. It is for moving the cursor one item downward when items are being selected or for changing the number/ character backward when data or parameter of the UPS is being set.

O. Enter key:

This is an LCD control key. It is for changing backward to the previous page, and also for confirming the number/character /item is selected.

P. Inverter on switch:

This is an inverter control switch. When this key is pushed with the control key simultaneously, the inverter will be switched on.

Q. Inverter control switch:

This is an inverter control switch. When this key is pushed with the inverter on key simultaneously, the inverter will be switched on. Similarly, when this key is pushed with the inverter off key simultaneously, the inverter will be switched off. Thus, this key is a guard for mistaken key strokes.

R. Inverter off switch:

This is an inverter control switch. When this key is pushed with the control key simultaneously, the inverter will be switched off.

Chapter 6. Maintenance

Topics:

- ^ *Safety Precautions (page 74)*
- ^ *Preventative Maintenance (page 75)*
- ^ *FRU Replacement (page 79)*
- ^ *Customer Service and Support (page 81)*

This chapter describes how to maintain the system.

6.1 Safety Precautions

Observe the following safety precautions when performing maintenance on the unit.



DANGER: Read and understand this section thoroughly before performing any maintenance work on or around the UPS. Read the battery manufacturer's manual and material safety data sheets before working on or near the batteries. Only normal safety precautions are required when the UPS is operating with all cabinet doors closed. However, the UPS cabinets or Battery cabinets (if applies) must be kept free of standing puddles of water, excess moisture, or debris. **Debris can consist of excessive dust in and around the unit, as the cooling fans in the UPS will pull this dust into the unit.**



DANGER: Only factory trained, or authorized personnel should attempt to install or repair the UPS or its battery system. Improper installation has proven to be the single most significant cause of start-up problems. Service personnel should wear insulating shoes for isolation from direct contact with the floor (earth ground) and should make use of rubber mats when performing maintenance on any portion of the unit while it is under power. High AC and DC electrical voltages are present throughout the unit(s) and incorrect installation or servicing could result in electrocution, fire, explosion, or equipment failure.



DANGER: Special safety precautions and lockout tagout procedures are required for all operations involving the handling, installation, or maintenance of the UPS system and any associated batteries or battery cabinets (if applies). Failure to follow safety procedures could result in death, injury or damage to equipment.



DANGER: This equipment contains circuits that are energized with high voltages. Only test equipment designed for troubleshooting high voltages should be used, particularly for oscilloscopes and probes. Always check with an AC and DC voltmeter to ensure safety before initiating contact or using tools. even when the power is off, dangerously high potential voltages may exist at capacitor banks. Always observe battery precautions when operating near any batteries. Failure to observe these precautions could result in death or in injury or damage to equipment.



DANGER: Observe all battery safety precautions during installation or service of the UPS or batteries. Even with the battery circuit breaker in the off position, the danger of electrocution may still be present. The battery power to the unit must be locked and tagged "off" before performing any service or work on the unit. The battery manufacturer's safety information and material safety data sheet are located in a pocket attached to the inside of left door of each UPS. Failure to follow those instructions and the instruction listed above and elsewhere in this manual could result in an explosion, fire, equipment failure, or electrocution.



DANGER: Be constantly aware that the UPS system contains high DC as well as AC voltages. With input power, off and the battery disconnected, high voltage at the filter capacitors and power circuits should discharge within 30 seconds. However, power circuit failures can occur, so you should always assume that high voltage might still exist after shutdown. Verify that power is off using AC and DC voltmeters before making contact.

6.2 Preventative Maintenance

UPS operator maintenance consists of the basic tasks in this section. Other maintenance functions require factory Certified Service personnel.

6.2.1 Maintaining an Operator's Log

Careful record-keeping ensures proper maintenance of the unit and assists in the correction of any abnormal conditions.

The operator's log should contain the following information:

- **Date of system start-up**
- **Dates that battery maintenance was performed**
- **Dates that input, output, and battery status readings were checked, and the values displayed for these readings**
- **Dates and summaries of all communications with Service personnel**
- **A copy of Service Log Sheet is provided with each unit, the form 6002-2017-04 can also be requested by calling customer service support.**

6.2.2 Periodically Testing the UPS

The unit should be manually exercised on a periodic basis (for example, once every three months) to force the UPS unit to transfer to the battery and return to main power. This process activates self-diagnostic testing that can reveal conditions that require attention.

6.2.3 Maintaining the Batteries



DANGER: The battery circuit breaker operates at the rated battery voltages at all times. A tripped battery circuit breaker indicates a serious problem that may result in serious injury or damage to the equipment. Determine the cause and take appropriate action as necessary. For example, check for a short circuit in the battery. For guidance, email Power Services at service@800pwrsrv.com



DANGER: The battery electrolyte is a diluted sulfuric acid that is harmful to the skin and eyes. It is electrically conductive and corrosive. Wear full eye and hand protection along with protective clothing. If the electrolyte contacts the skin, wash it off immediately with water. If electrolyte contacts the eyes, flush thoroughly and immediately with water. Seek immediate medical attention. Spilled electrolyte should be washed down with a suitable acid neutralizing agent. One common practice is to use a solution of approximately one pound (450 grams) of bicarbonate of soda to approximately one gallon (4 liters) of water. The bicarbonate of soda solution should be applied to the spill until evidence of chemical reaction (foaming) has ceased. The resulting liquid should be flushed with water and the area dried.



DANGER: Do not dispose of a battery or batteries in a fire. The batteries may explode causing death or serious injury.



Caution: Do not substitute batteries from other manufacturers without the express approval of the manufacturer Customer Service personnel.



Caution: Lead-acid batteries contain hazardous materials and must be handled, transported, and recycled or scrapped in accordance with federal, state, and local regulations. Since lead is a toxic substance, lead-acid batteries should be recycled rather than scrapped.



Caution: A battery can present a risk of electrical short and high short circuit current. The following precautions should be observed when working on or around batteries:

1. **Remove watches, rings, or other metal objects.**
2. **Use tools with insulated handles.**
3. **Wear rubber gloves and boots.**
4. **Do not lay tools or metal parts on top of batteries.**
5. **Disconnect charging source prior to connecting or disconnecting battery terminals.**
6. **Determine whether battery is inadvertently grounded. if so, remove the source of the ground. Contact with any part of a grounded battery can result in electrical shock. The likelihood of such shock will be reduced if such grounds are removed during installation and maintenance.**



DANGER: Do not ground battery positive or negative.



Caution: Lead-acid batteries can present a risk of fire because they generate hydrogen gas. The following safety procedures must be followed:

- **Do not smoke when near batteries.**
- **Do not cause flames or spark in the batteries' area.**
- **Discharge static electricity from your body before touching batteries by first touching a grounded metal surface.**



Use of any non-Factory Tested/UL924 Certified batteries, including those with similar brand name and part number, will void the systems UL 924 Safety Certification Listing. Please call or e-mail Power Services for tested/certified replacement batteries.



Caution: The average annual ambient temperature of the batteries shall not exceed 77° F.



Caution: Battery Cell temperatures shall not exceed 92° F for more than 30 days annually.



Caution: Batteries are required to be installed and charged within 90 days of shipment.

6.2.4 Battery Cabinets

Although the individual batteries are sealed and require only minimal maintenance, they should be given a periodic inspection and electrical check. (Refer to schedule in log sheet provided inside front door pocket) to ensure years of trouble-free service. Tightness of battery terminal connections and interconnections between cabinets should be tested to recommended torque values. Battery Service Agreements are available through www.800pwrsrvc.com. For information about battery environment specifications, see Table -4-3

To qualify for battery-warranty replacement, you will need to show records of the battery maintenance history including battery numbers, battery voltages (individual cells), terminal torque measurements and dates of maintenance.

6.2.5 Power Connections

Check for corrosion and connection integrity. Visually inspect wiring for discolored or cracked insulation. Clean and/or re-torque as required.

All battery terminal connections must be tightened with the proper torque value set in accordance with the torque value on the Battery Connection Diagram provided with each system.

Use the correct torque tool to tighten the terminal bolts shown on the drawings shipped with each system. Use all hardware provided with the batteries.



Caution: Torque all connections in accordance with specified values provided. Failure to do so can create an unsafe condition or fire hazard.

6.2.6 Preventative maintenance

Programs are available through the Customer Service representative.

6.2.7 Battery Terminals

Check for discoloration, corrosion, and connection integrity. Clean and tighten as necessary.

To access battery terminals:

1. Remove the top strapping material located at the lower front of the battery shelf.
2. Pull the battery forward to access the battery connections.
3. Disconnect the cables connected to the battery, and then use a protective boot or electrical tape to insulate the cables to prevent accidental shorts.
4. Before replacing the battery connections, clean and re-torque the connection hardware.

6.3 FRU Replacement

Some components can be replaced by qualified factory-trained service personnel only. These components are referred to as Field Replaceable Units (FRUs).

Refer to

Table 6-1 for ordering the replacement parts from the factory. Provide the unit’s Serial No. from the Start-Up label located on the right front door.

Email service@800pwrsrc.com for replacement parts. Replacement parts must be replaced by certified factory-trained service personnel only.



Electrostatic Sensitive: Circuit boards and IGBTs contain Electrostatic Discharge Susceptible (ESDS) components. Handle and package ESDS devices in accordance with JEDEC standard JESD625-A. Use a grounded ESD wrist strap when handling the devices and circuit boards. Always package components and circuit boards in static-dissipative plastic bags before transporting even if a device has failed. Failure to do so could result in further damage, complicating repair and failure analysis.

Table 6-1 Field Replacement Assemblies (FRU)

Item	Description	Designator
1	Rectifier / Static Transfer Kit, 6 pulse, 24kW,	9100-1590-030

Maintenance

Item	Description	Designator
2	Rectifier / Static Transfer Kit, 6 pulse, 32kW,	9100-1590-040
3	Rectifier / Static Transfer Kit, 6 pulse, 40kW,	9100-1590-050
4	Rectifier / Static Transfer Kit, 6 pulse, 50kW,	9100-1590-060-EL
5	Rectifier Kit, 12 pulse, 64kW	9100-1593-080
6	Rectifier Kit, 12 pulse, 80kW	9100-1593-100
7	Rectifier Kit, 12 pulse, 96kW	9100-1593-120
8	Rectifier Kit, 12 pulse, 128kW	9100-1593-160
9	Rectifier Kit, 12 pulse, 160kW	9100-1593-200
10	Rectifier Kit, 12 pulse, 192kW	9100-1593-240
11	Static Transfer Switch Kit, 12 pulse, 64kW	9100-1594-080
12	Static Transfer Switch Kit, 12 pulse, 80kW	9100-1594-100
13	Static Transfer Switch Kit, 12 pulse, 96kW	9100-1594-120
14	Static Transfer Switch Kit, 12 pulse, 128kW	9100-1594-160
15	Static Transfer Switch Kit, 12 pulse, 160kW	9100-1594-200
16	Static Transfer Switch Kit, 12 pulse, 192kW	9100-1594-240
17	Inverter Kit, 6 pulse, 24kW	9100-1595-030
18	Inverter Kit, 6 pulse, 32kW	9100-1595-040
19	Inverter Kit, 6 pulse, 40kW	9100-1595-050
21	Inverter Kit, 6 pulse, 50kW	9100-1595-060
22	Inverter Kit, 12 pulse, 64kW	9100-1595-080
23	Inverter Kit, 12 pulse, 80kW	9100-1595-100
24	Inverter Kit, 12 pulse, 96kW	9100-1595-120
25	Inverter Kit, 12 pulse, 128kW	9100-1595-160
26	Inverter Kit, 12 pulse, 160kW	9100-1595-200
27	Inverter Kit, 12 pulse, 192kW	9100-1595-240

6.3.1 All Other Parts

Verify that the cables are marked before disconnecting. Replace the defective part with the new part. Reconnect wiring the same way as it was connected.

6.3.2 Calling for Service

Call for service if you encounter any of the following conditions:

- Repeated start-up attempts are unsuccessful.
- A UPS fault occurs that cannot be cleared.
- Normal operation of the critical load repeatedly causes an overload condition. This is not a UPS fault. A qualified person must analyze the total load connected to the UPS to prevent unit failure. Momentary overload conditions will be handled within the parameters of the UPS unit, but sustained overloads will cause the UPS Unit to fail.
- Any indicators or alarms operate abnormally or continuously.
- Any other abnormal function of the system occurs.
- If any abnormal battery condition is detected.
- When you are unsure of what action to take.
- If any of the above occurs:
- Fill out a service request form by visiting www@800pwrsrc.com or email service@800pwrsrc.com



DANGER: Lethal voltages are present inside the equipment even when there appears to be no input power to the unit. Protect yourself from the risk of electrocution by referring service to qualified personnel only.

6.4 Customer Service and Support

Start-up, UPS maintenance, battery maintenance, and preventative maintenance programs are available through your Factory sales representative.

6.4.1 Start-Up Services

Various start-up services are available. Contact your sales representative or email us at service@800pwrsrc.com

6.4.2 Maintenance Agreements

Standard Full Service, 24/7 Full Service, and Extended On or Off-Site Maintenance agreements are available. Contact your sales representative or email service@800pwrsrv.com

6.4.3 Warranties

If you have any questions about the warranty on your UPS System or the batteries email us at service@800pwrsrv.com or contact Customer Service and Support at 1-800-[PWR-SRVC \(800-797-7782\)](tel:800-797-7782).

Chapter 7. Troubleshooting

Topics:

- ^ *Troubleshooting Guide*
(page 84)

This chapter describes typical LCD screens and some typical troubleshooting steps.

7.1 Troubleshooting Guide

Figure 7.1

Line	Abnormal	Description & Checkpoint	Solution
1	AC input is correct, but rectifier does not operate and RECT AC FAIL LED lights up.	The rectifier breaker is not switch on.	Switch on the rectifier breaker.
		The input voltage is not correct (out of the normal range).	Connect the right AC source.
		The phase sequence of AC input is incorrect, input rotation error, and the LCD will display warning message "RECT PHASE ERROR" in the STATUS/WARN menu (MAIN menu → SELECT menu → STATUS/WARN menu). ROTATION ERROR LED on left side of the front panel will also light.	Correct the R.S.T. phase sequence. Generally, to exchange any two phases connection can solve this problem.
		If the abnormality cannot be corrected when the solution actions have been taken.	Refer to PCB LED Detecting Guide and check the 3C PCB.
2	The unit shuts down under AC mains failure.	The battery fuse (breaker/holder/dis-connector) has not been closed.	Close the battery fuse breaker/holder/dis-connector.
3	No power supply for UPS control circuit and LCD cannot display.	The reserve breaker has not been closed (switched on).	Close the reserve breaker.
		3B PCB has problem.	Refer to PCB LED Detecting Guide and check the 3B PCB.
4	The voltage difference between NEUTRAL and GROUND has become abnormally high.	There is external wiring error of R.S.T phase and N. G., instead of ELI unit itself.	Correct the external wiring system.
5	The inverter cannot start up.	Other than INVERTER SS LED in left side of the front panel, other LEDs still illuminate.	Do trouble shooting according to the LED instruction.
		Switch on the inverter before DC bus has been established completely. Normally, it takes around 30 seconds to establish the DC BUS once the reserve and rectifier breakers are closed.	Refer to the switch on procedure. Close the reserve and rectifier breakers and wait around 30 seconds or directly use batteries to establish the DC bus.
		Bypass breaker has been closed (switched on).	Open the bypass breaker.



Troubleshooting

Line	Abnormal	Description & Checkpoint	Solution
		The output is overloaded. The LCD will display warning message 'XXX% OVERLOAD' in the STATUS/WARN menu (MAIN menu → SELECT menu → STATUS/WARN menu). XXX% OVERLOAD LED on left side of the front panel and OVERLOAD LED on right side will also light.	Decrease the load to below the ELI's rated power.
		In P&P modules1, the temperature sensor sockets on 3G PCB and heatsink are not connected properly. WARNINGLED of FUSE/TEMP still illuminate but LED in 3G PCB doesn't, indicating DC BUS may be over 240VDC.	Take out the P&P modules and connect them properly.
6	Fans do not work while ELI is on.	The fuses positioned behind PCB holder have been blown or are not installed properly.	Replace the fuses or install them properly.
		Abnormal voltage output in R phase.	Refer to PCB LED Detecting Guide and check the 3T PCB of R phase.
7	The rectifier shunt down and HIGH DC LED is lit.	Voltage limit function failure in the 3B, which contributes to the DC voltage, goes over 430V.	Refer to PCB LED Detecting Guide and check the 3B PCB.
		3C PCB has problem.	Refer to PCB LED Detecting Guide and check the 3C PCB.
8	Abnormal voltage in reserve.	RESERVE AC FAIL LED lights up. LCD menu also displays the abnormal voltage in reserve. (REAL TIME DATA menu → RESERVE DATA menu).	Check the reserve wiring and connect with the correct source.
		Fuse has blown in 3A PCB	Replace the fuse.
		If the abnormality cannot be corrected after the solution actions have been taken.	Refer to PCB LED Detecting Guide and check the 3A PCB.

Troubleshooting

Line	Abnormal	Description & Checkpoint	Solution
9	Abnormal frequency in reserve.	RESERVE FREQ FAIL LED lights up. LCD menu also displays the abnormal voltage in reserve. (REAL TIME DATA menu → RESERVE DATA menu).	Check the reserve wiring and connect with the correct source.
		Fuse has blown in 3A PCB	Replace the fuse.
		If the abnormal cannot be corrected after the solution actions have been taken.	Refer to PCB LED Detecting Guide and check the 3A PCB.
10	The inverter shuts down during operation, while the FAULT LED lights and buzzer beeps continuously.	Bypass breaker has been closed (switched on).	Open the bypass breaker. The inverter will restore running automatically.
		The output is short-circuited, including the load itself.	Clear the short circuit at the output, then switch off the inverter.
		Secondly, switch on once more to restart the inverter.	
		The output is overloaded. The LCD will display warning message 'XXX% OVERLOAD' in the STATUS/WARN menu (MAIN menu → SELECT menu → STATUS/WARN menu). XXX% OVERLOAD LED on left side of the front panel and OVERLOAD LED on right side will also light.	Decrease the load to under the ELL's rated power. Then the inverter will restore running automatically.
		Heat Sink is over temperature. WARNING LED of FUSE/TEMP still illuminates.	Decrease the load to under the ELL's rated power, then switch off the inverter. Secondly, switch on once more to restart the inverter.
		IGBT-protect fuse has blown in P&P module1 or IGBT damage.	Take out the P&P module and replace fuse or IGBT.
		When in battery back-up mode, the inverter shuts down due to battery low (lower than 295VDC).	Within 30 minutes, the inverter will restore running automatically once the AC main is back.
11	Transferring failure between reserve and inverter.	DC BUS voltage becomes abnormal during transferring. DCV value can be read in LCD menu.	Take out the P&P module 2 and make sure the SCR drive connection is OK.
		3P PCB has problem.	Refer to PCB LED Detecting Guide. Take out the P&P module 2 and check the 3P PCB.

Troubleshooting

Line	Abnormal	Description & Checkpoint	Solution
		LED A4(OTF) in the 3A PCB lights.	Refer to PCB LED Detecting Guide and check the 3G PCB.
		In P&P modules, the temperature sensor sockets on 3G/3P PCB and heatsink are not connected properly. WARNING LED of FUSE/TEMP still illuminates.	Take out the P&P module and connect them properly.
		Phase sequence error of output transformer.	Change the transformer wiring.
12	Phase lack when AC output.	The mimic output LED in the front panel blinks.	Make sure the signal sockets in 3T PCB are connected properly.
		Fuse has blown in 3T PCB	Replace the fuse.
		If the abnormal cannot be corrected after the solution actions have been taken.	Refer to PCB LED Detecting Guide and check the 3T PCB.
13	The mimic battery LED in the front panel blinks.	Batteries become worn out or damaged.	Replace batteries.
14	(14) All LED in the front panel light up.	CPU inserting error in 3A or 3R PCB	Insert the CPU into correct socket.
15	Communication interface is not working properly.	Communication cables are connected improperly.	Correct the wiring.
		Communication software is not installed successfully.	Reinstall the software.
		Communication port setup error.	Correct the setup.
		CPU inserting error in 3R PCB.	Insert the CPU into right socket.
		If the abnormal cannot be corrected after the solution actions have been taken.	Refer to PCB LED Detecting Guide and check the 3R PCB.
16	The inverter has been turned on but no action of inverter.	The inverter switches of  &  are not pressed simultaneously.	Try to press these two buttons simultaneously
		PCB Connection is not good.	Refer to PCB LED Detecting Guide and check the connection of 3W PCB.

APPENDIX A - BATTERY CONNECTIONS

This appendix shows typical battery connection diagrams. The figures are provided for electrical connection only and do not necessarily match the actual battery layout in your unit. The arrangement may be different from the figures. Each system is shipped with its own battery connection diagram located inside the front door pocket.



DANGER: The use of a physically damaged battery can cause a catastrophic system failure and can even result in a fire or explosion that could endanger life and property. Before accepting a battery shipment from the carrier, please read and follow these instructions:

1. Thoroughly inspect each battery for any signs of damage. If there is any damage, reject the shipment and notify the manufacturer. If possible, photograph the damage for future reference.
2. As you unpack the pallet or container, check each battery box for damage on all sides, the top and bottom. If there is any sign of damage, photograph the damage if possible, and contact Power Service.
3. Before you install each battery in the cabinet, remove it from its carton and thoroughly inspect it again on every side, the top and bottom for any signs of physical damage including, but not limited to, cracks, chips, leaks, bulges, and so forth.
4. If a battery is dropped or makes hard contact with any object, inspect it again.
5. Batteries are heavy, so exercise care when lifting them onto the shelves.
6. Use of any non-Factory Tested/UL924 Certified batteries, including those with similar brand name and part number, will void the systems UL 924 Safety Certification Listing. Please call or e-mail Power Services for tested/certified replacement batteries.
7. If at any time you have any questions regarding the condition of a battery, set it aside and notify the manufacturer email: Service@800pwrsrc.com, or call at 800-PWR-SRVC (800-797-7782). Do not use a questionable battery under any circumstances, even temporarily.

Appendix A - Battery Connections

Typical Standard Battery cabinet(s) weight			
Cabinet Qty	Each Cabinet Dimensions (Inches)	Total Battery cabinet approx. max. weight (lbs.) (Including batteries)	Floor Loading Lbs./Sqft
1	51 x 70 x 30.5	3288	175~304
2	51 x 70 x 30.5	10609	304~491
3	51 x 70 x 30.5	14401	444
4	51 x 70 x 30.5	34868	537~807

Appendix A - Battery Connections

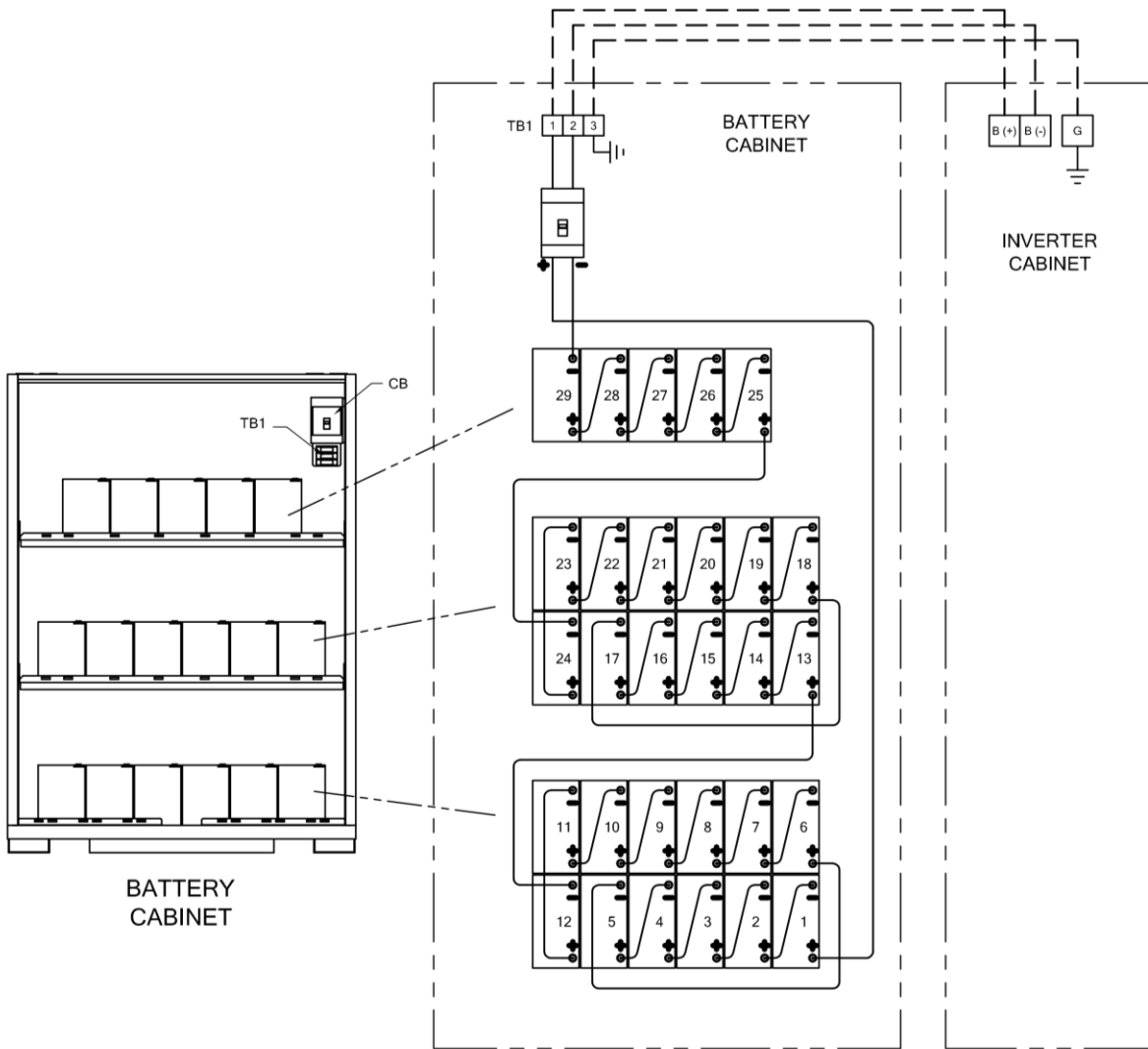

348 Volt Nominal DC Voltage

1 String of 29 Battery, 1 Battery Cabinet (Typical)

Appendix A - Battery Connections

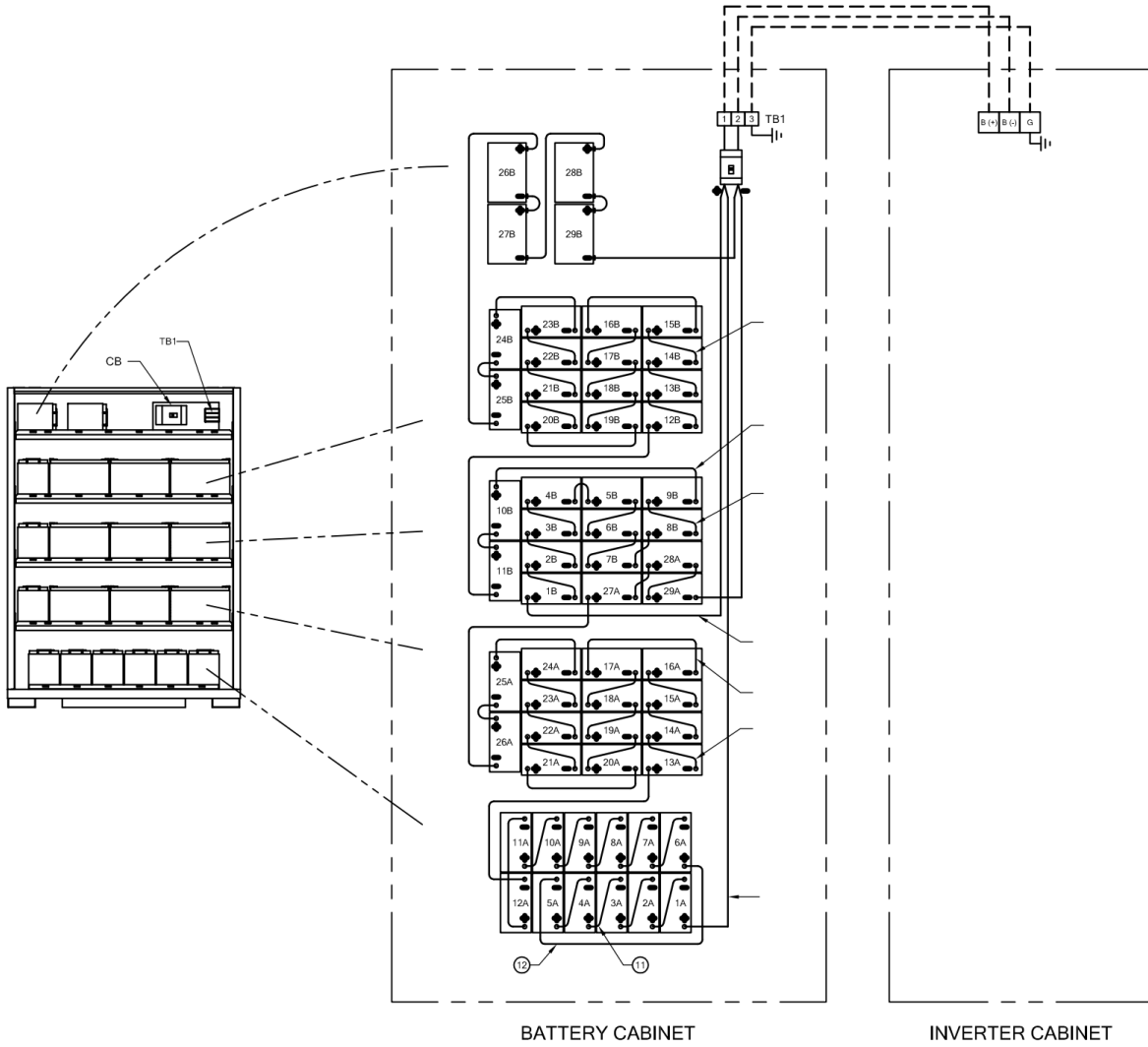

348 Volt Nominal DC Voltage

2 String of 29 Battery, 1 Battery Cabinet (Typical)

Appendix A - Battery Connections

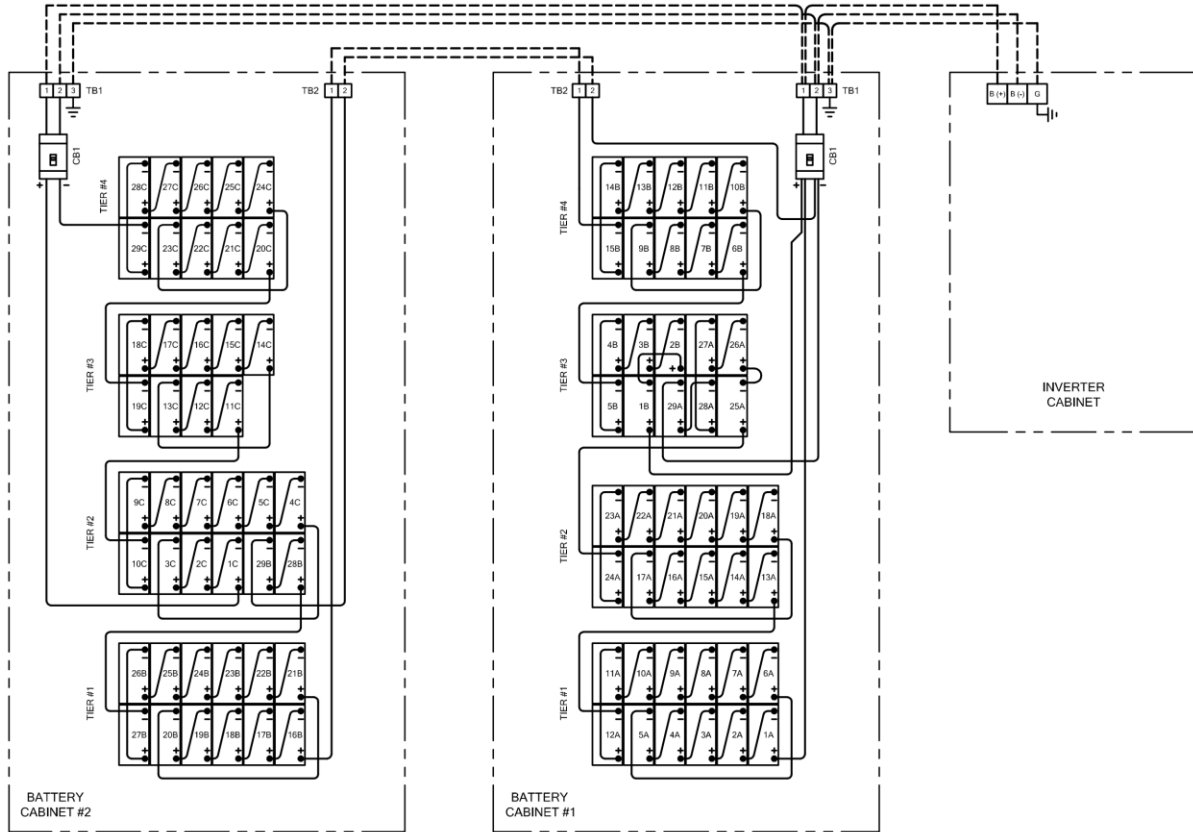

348 Volt Nominal DC Voltage

3 String of 29 Battery, 2 Battery Cabinet (Typical)

Appendix A - Battery Connections

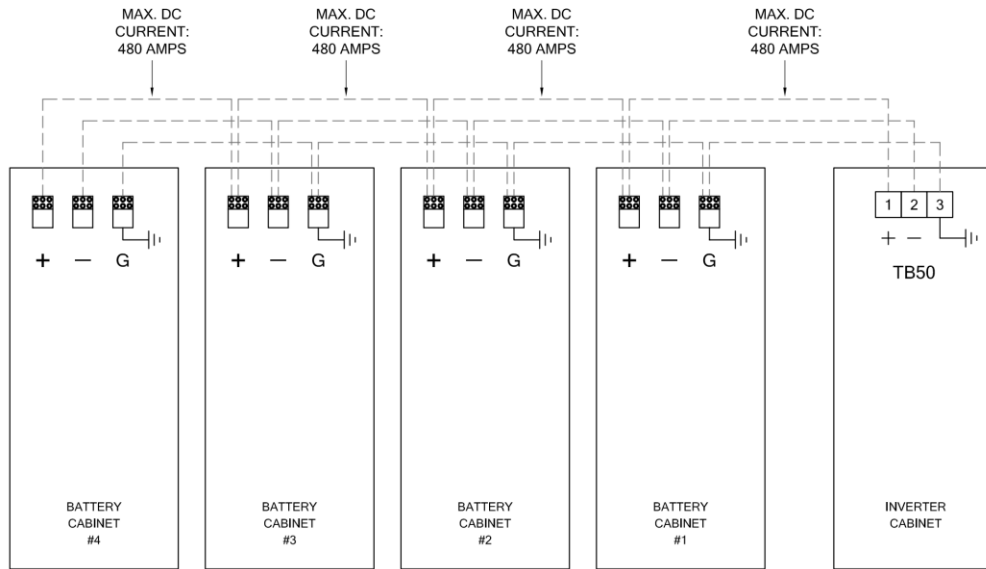

NOTES:

- 1) POSITION ALL BATTERIES AS SHOWN.
- 2) CAREFULLY OBSERVE BATT POLARITY WHEN MAKING BATTERY CONNECTION.
- 3) ALL CONNECTIONS SHOWN IN DOTTED LINES TO BE PROVIDED BY CUSTOMER.
- 4) LABEL BATTERY NUMBERS AS SHOWN.
- 5) BATTERY CABINETS:
 CABINET #1 = STRING A (BATTERY 1A THRU 29A)
 CABINET #2 = STRING B (BATTERY 1B THRU 29B)
 CABINET #3 = STRING C (BATTERY 1C THRU 29C)
 CABINET #4 = STRING D (BATTERY 1D THRU 29D)
- 6) BATTERY TORQUE: 100 IN-LBS.

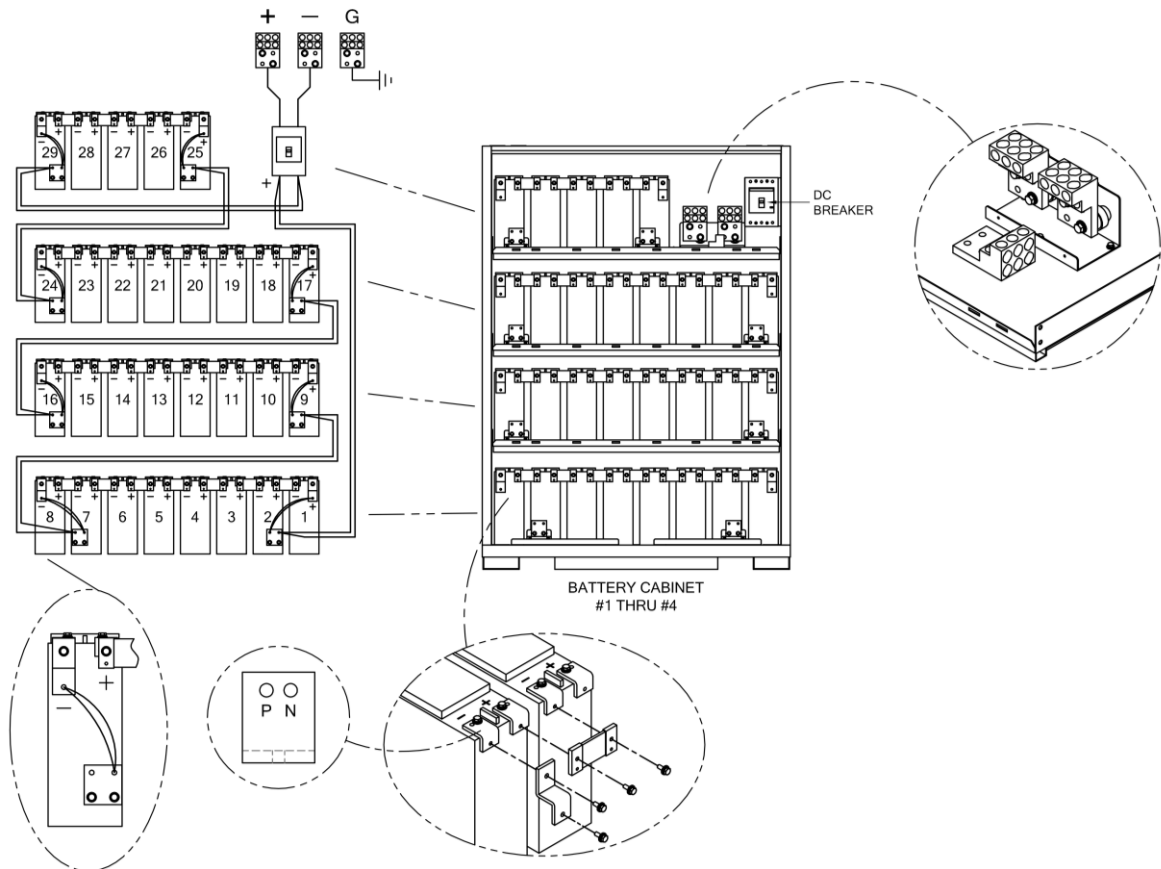

**348 Volt Nominal DC Voltage
4 String of 29 Battery, 4 Battery Cabinet (Typical)**

APPENDIX B - OPTIONS

B.1 Dry Contacts

Optional Seven (7) dry contact terminals shall be provided. These terminals are Normally Closed (conducting) dry contacts. When an event occurs, the terminal will open (non-conducting). Maximum contact rating is 16A/250VAC (16A/30VDC). The connections provided are:

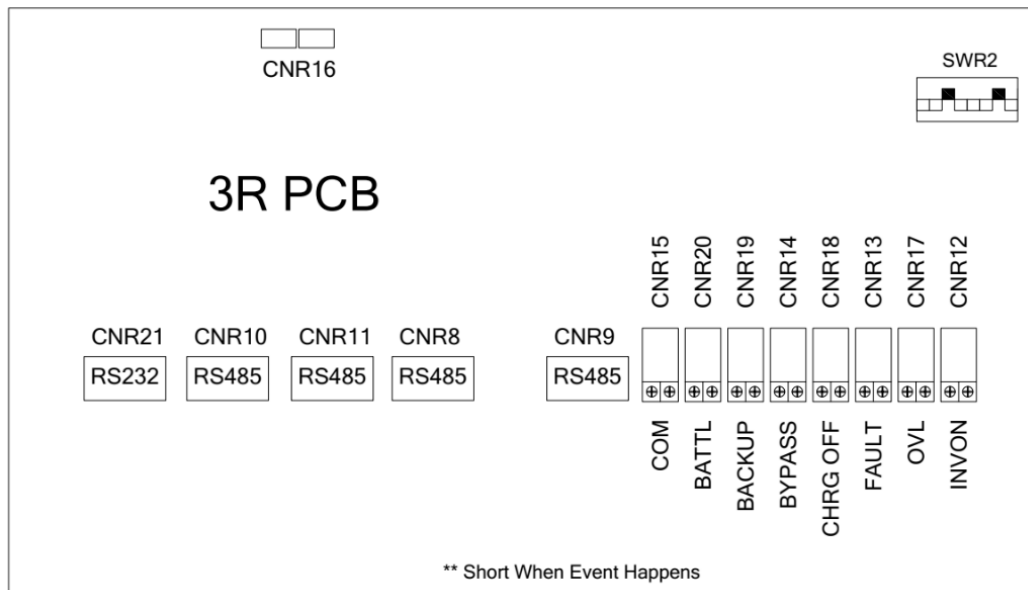

- CNR20- (BATTERY LOW) When Battery voltage drops below threshold (310 VDC) while system is running on battery mode.
- CNR19- (ON BATTERY BACKUP) When Utility Power is not present, the unit is on Battery Power.
- CNR14 – (BYPASS ON) The unit is on Bypass Mode.
- CNR18 – (Charger OFF) When unit on Battery Backup and Batteries Overheat
- CNR13- (UPS FAULT) During normal Operation.
- CNR17 – (OUTPUT OVERLOAD) Overload on the Output
- CNR12- (INVERTER ON) Unit is on Inverter.
- CNR15 – (COM) This contact can be configured as the OR result of the signals described above. SWR2-1 (dip-switch pin 1) ~ SWR2-7 (dip-switch pin 7) can select one of the seven signals described above and SWR2-8 is the COM enable switch. Please refer to the dip-switch of SWR2 on the 3R PCB and the following examples and diagram.

Example 1:

If two contacts for BACK-UP are required. Switch on SWR2-6 & SWR2-8, then both CNR19 & CNR15 will OPEN when the unit goes to back-up.

Example 2:

If one contact for OVL & FAULT is required. Switch on SWR2-2 & SWR2-3, then the CNR15 will OPEN when either OVL or FAULT condition happens. Of course, CNR17 will OPEN when OVL happens and CNR13 will OPEN when FAULT happens.

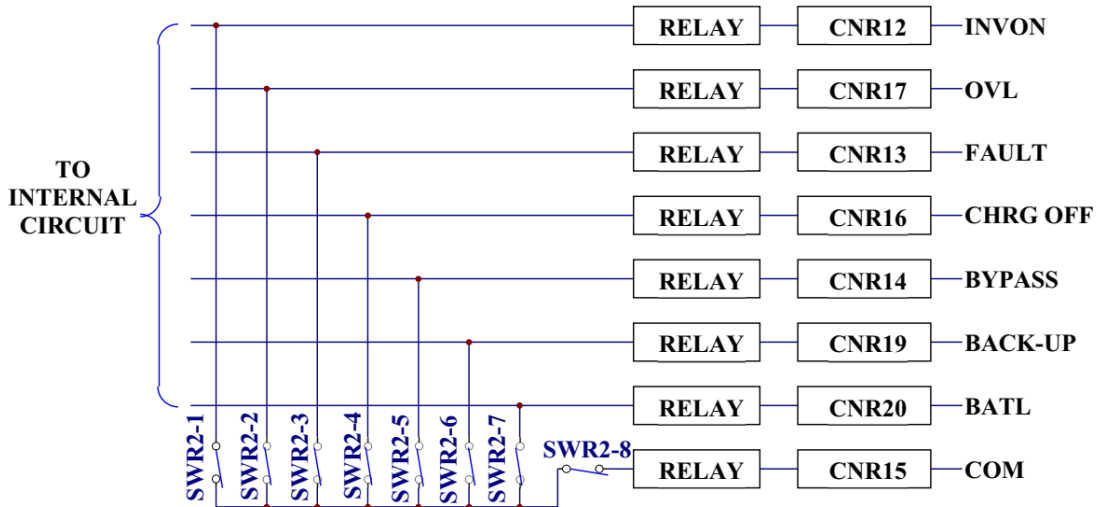

SWR2-DIP SWITCH ON 3R PCB

B.2 Sub-Feed UL489 Breaker for Elevator

These optional breakers ratings can be specified per required power.

B.3 Sub-Feed UL489 Breaker for Emergency Lightings.

These optional breakers ratings can be specified per required power.

B.4 Regen Manager (for Regen Elevators):

During a power outage, the optional Regen Manager converts regenerative power generated by elevator to DC power supplying power to the batteries thus extending the Battery Backup time. During normal mode, the optional Regen Manager will feed the regenerative power to the building. Additionally eliminating the requirement for a traditional Automatic Transfer Switch (ATS) and its associated circuitry. This reduces the system's footprint, load **banks**,

cooling systems, and the need for onsite maintenance through remote monitoring capabilities.

B.5 Battery to Utility Time Delay (120 sec or 60 sec)

Selectable time delay (60 or 120 seconds) to allow elevator control to switch to normal power, thus eliminating the need for ATS Switch.

B.6 Main Input CB custom KAIC

When Hi custom KAIC rating option is used Input Cable securement to the Terminal Block must comply with the following diagram

B.7 Main Output CB custom KAIC

When Hi custom KAIC rating option is used Output Cable securement to the Terminal Block must comply with the following diagram

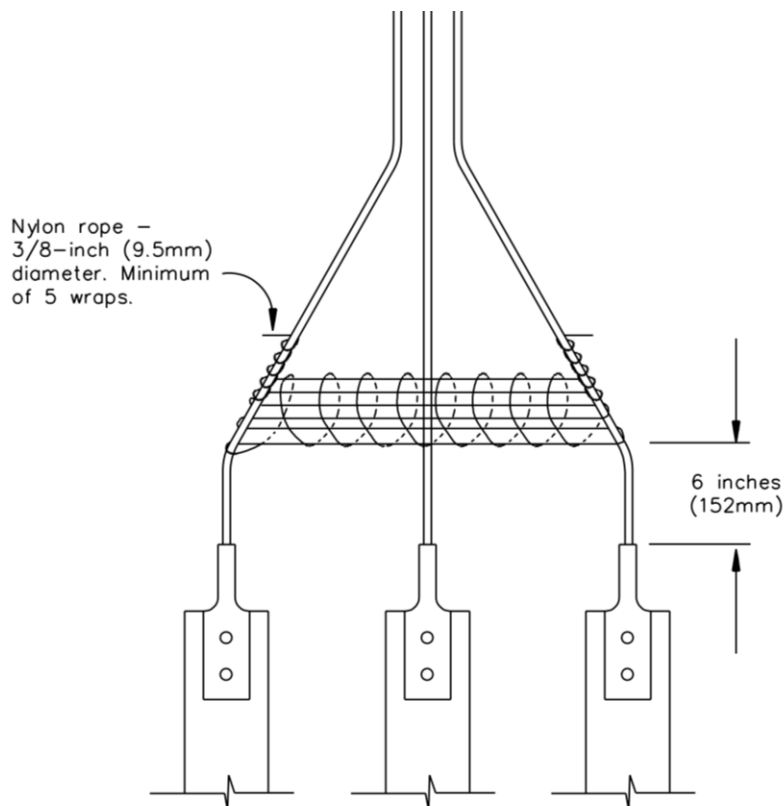

B.5.2 External Shutdown

2 pairs of terminals CNR 16 are provided for external shutdown. 10mA is needed for turning on the internal photo-coupler. The user can use this terminal to shut-down the unit when emergency conditions occur, such as fire, short circuit etc.

B.5.3 DB9 Connection

Four RS-485 and one RS-232 are provided to communicate with more sophisticated (option) modules. Each connector is especially dedicated to one type of external module. The following are some connection examples of optional modules.

- CNR21 (RS-232) ⇔ UPSCOM- Software for PC Monitoring-SNMP Card
- CNR9 (RS-485) ⇔ DCMAN- Battery Monitoring Module
- CNR10 (RS-485) ⇔ UPSCAN- Remote Control Panel
- CNR12,13,14,15,17,18,19 (RS-485) ⇔ UPSCALL- Auto Dialing Module
- CNR11 ⇔ for transferring RS-485 into RS-232

B.5.4 Local Monitoring via PC with RS-485 or RS232

B.5.5 Simple Network Management Protocol

This option consists of a basic SNMP NetAgent SNMP device.

B.8 Seismic Mounting Bracket

The seismic floor mounting bracket includes one left bracket and one right bracket per cabinet (UPS and Battery)

B.9 Battery String Monitoring (Wireless).

The wireless battery monitoring system continuously monitors and communicates with the data collector to provide Real-time data. It analyzes and stores battery string voltage, current and (optional) cabinet temperature. For detail information request literature or visit our website.

B.10 Battery (Individual) Monitoring (Wireless)

The wireless battery monitoring system for individual battery block monitors each battery voltage, battery impedance and (optional) battery temperature. For detail information request literature or visit our website.

B.11 Battery Thermal Runaway Control

This option provides protection in case of over-temperature condition in the battery compartment. If such a condition occurs, this option shuts off the charger. Charging resumes when the temperature returns to normal. A dry contact (N/O, N/C) relay interface is provided for this option for user interface per following:

Terminal Number	Signal	Description
TB121-1	N/C	N/C contact that opens when the critical temperature has reached
TB121-2	COM	Common
TB121-3	N/O	N/O contact that closes when the critical temperature has reached

B.12 Battery Breaker Alarm

It provides a signal when the battery breaker is in OFF position.

B.13 Battery Thermal Runaway Control with dry contact for remote monitoring

Provides protection in case of over temperature condition in each battery cabinet (s) by shutting off the charger, it allows remote monitoring of the condition and will resume charging when temperature has return to normal.

B.14 Battery Cabinet exhaust fan only without alarm and indicator

B.15 Battery Cabinet exhaust fan with local alarm, indicator and dry contact for remote monitoring

It provides a local alarm, indicator and remote signal through Dry contact in case of the fan failure in the battery cabinet (s).

B.16 Delta Input/Output systems

- **Delta**
- **Hi-Legged Delta (3 single phases with 1 leg Grounded).**

B.17 Battery Exerciser (setting)

1. Connect the DB9 wire from upper socket of CNR21 to USB of Laptop via a RS-232 to USB converter.

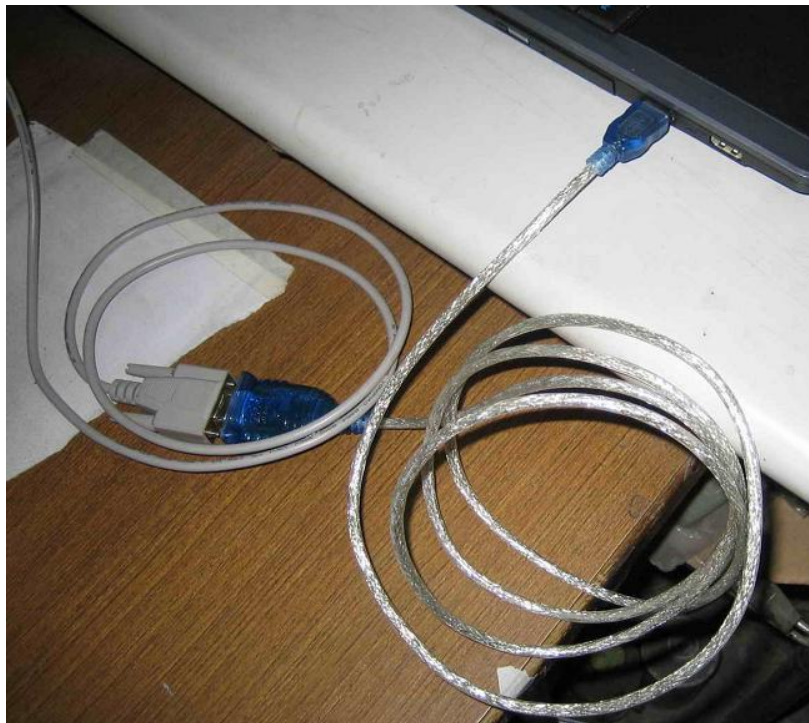

Caution: UPS should be grounded to avoid noise interfering the laptop.

Install UPSCOM-1 CD

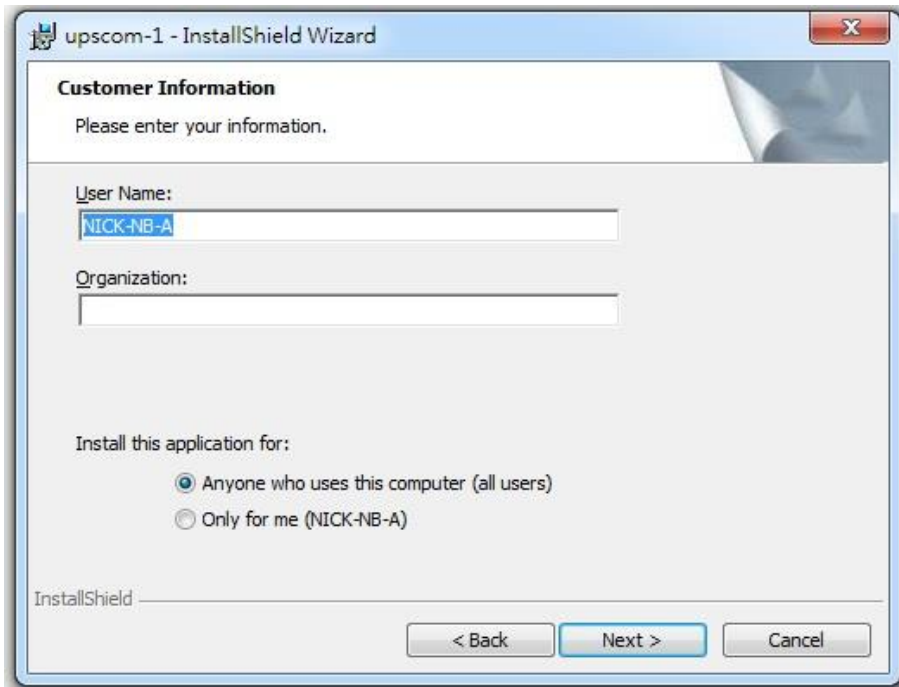

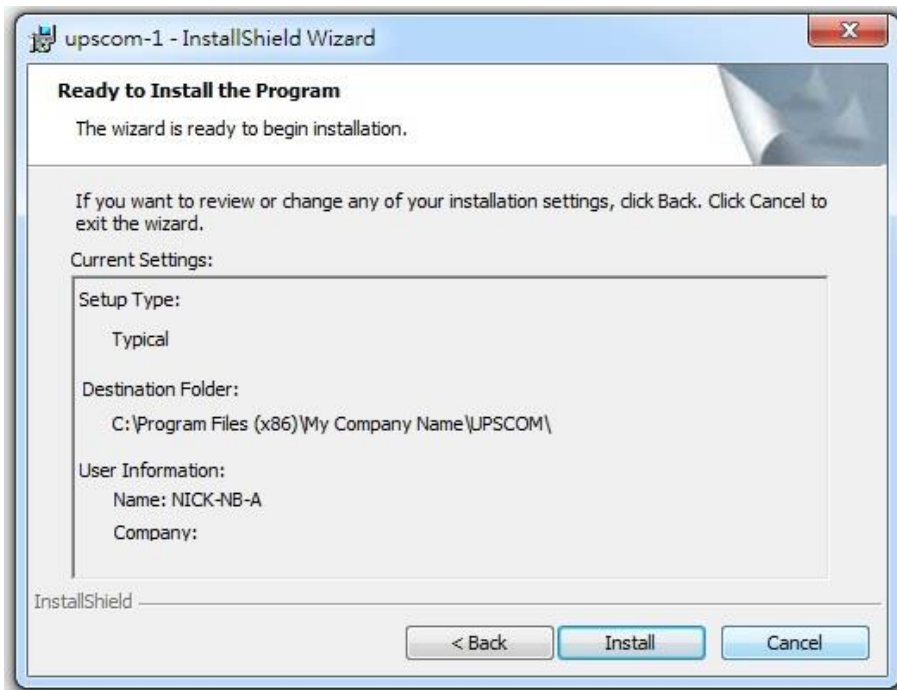
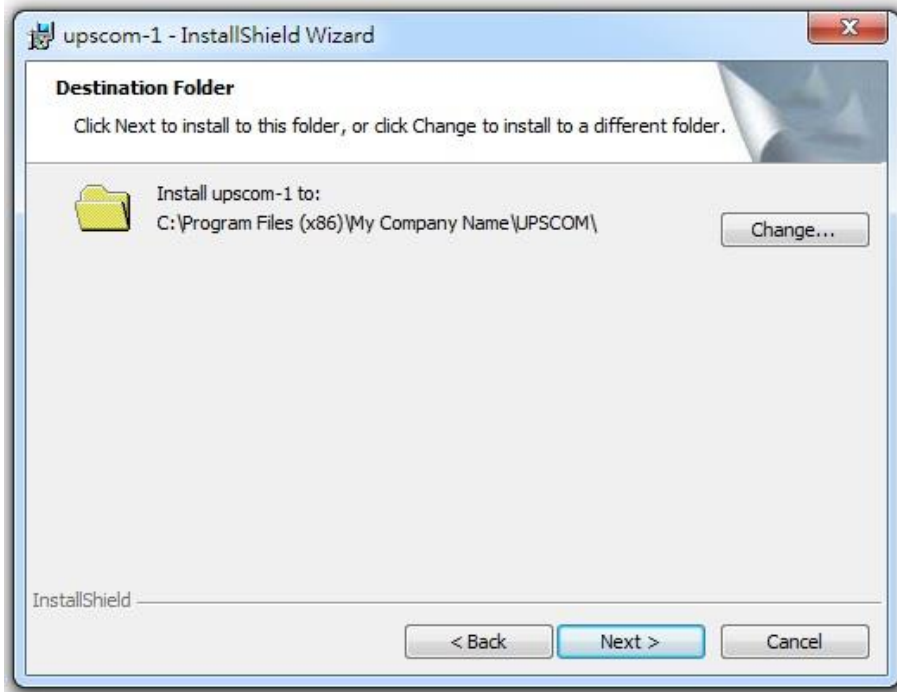

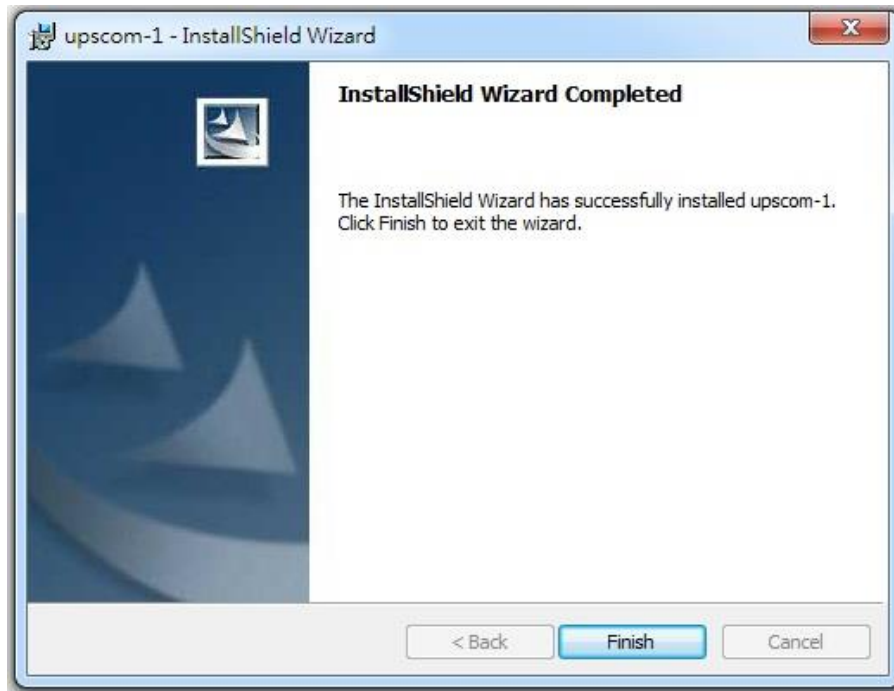

2. Double click UPSCOM-1 to launch the Program.



3. Set up "Communication Port property"

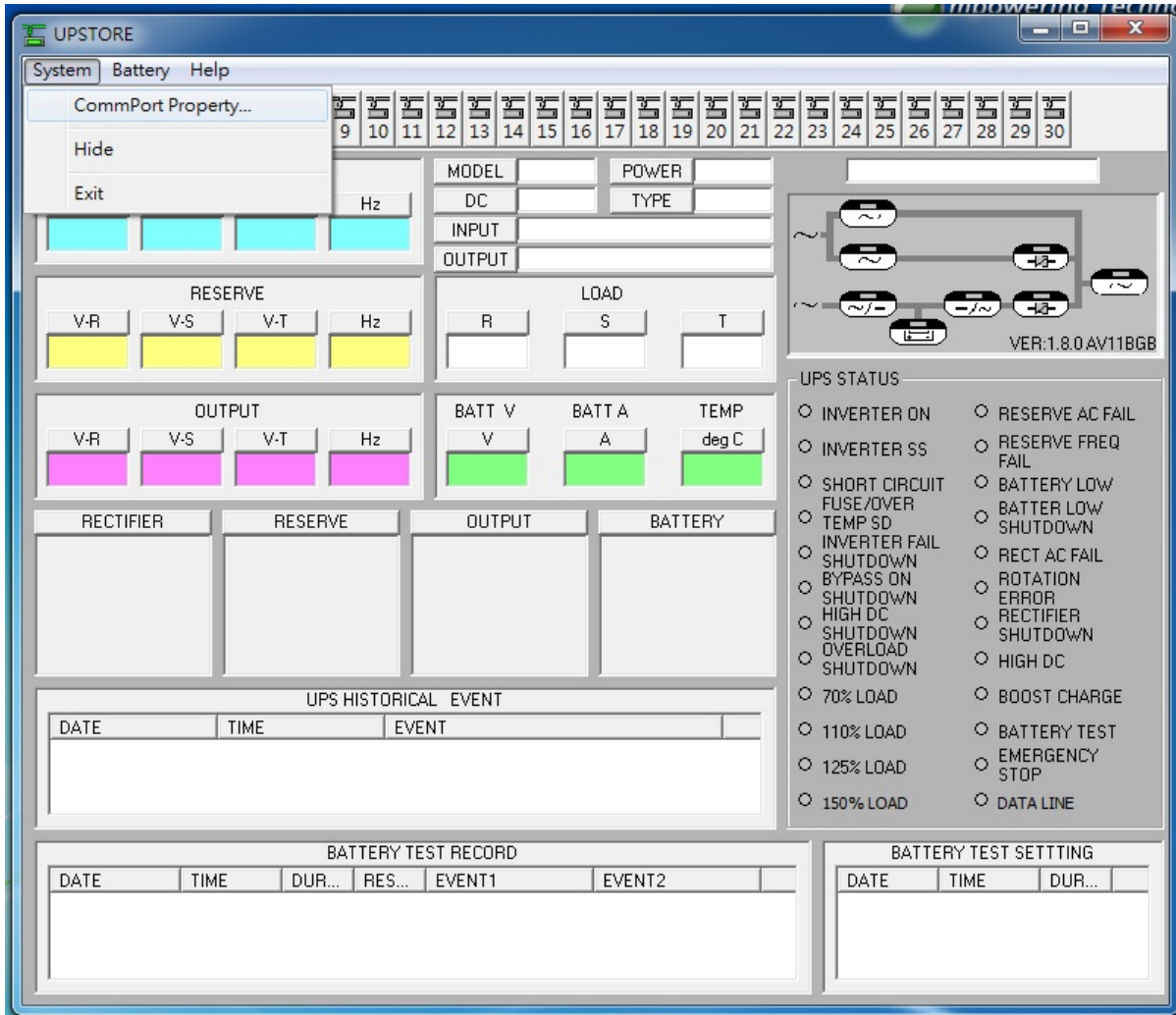

Appendix B - Options

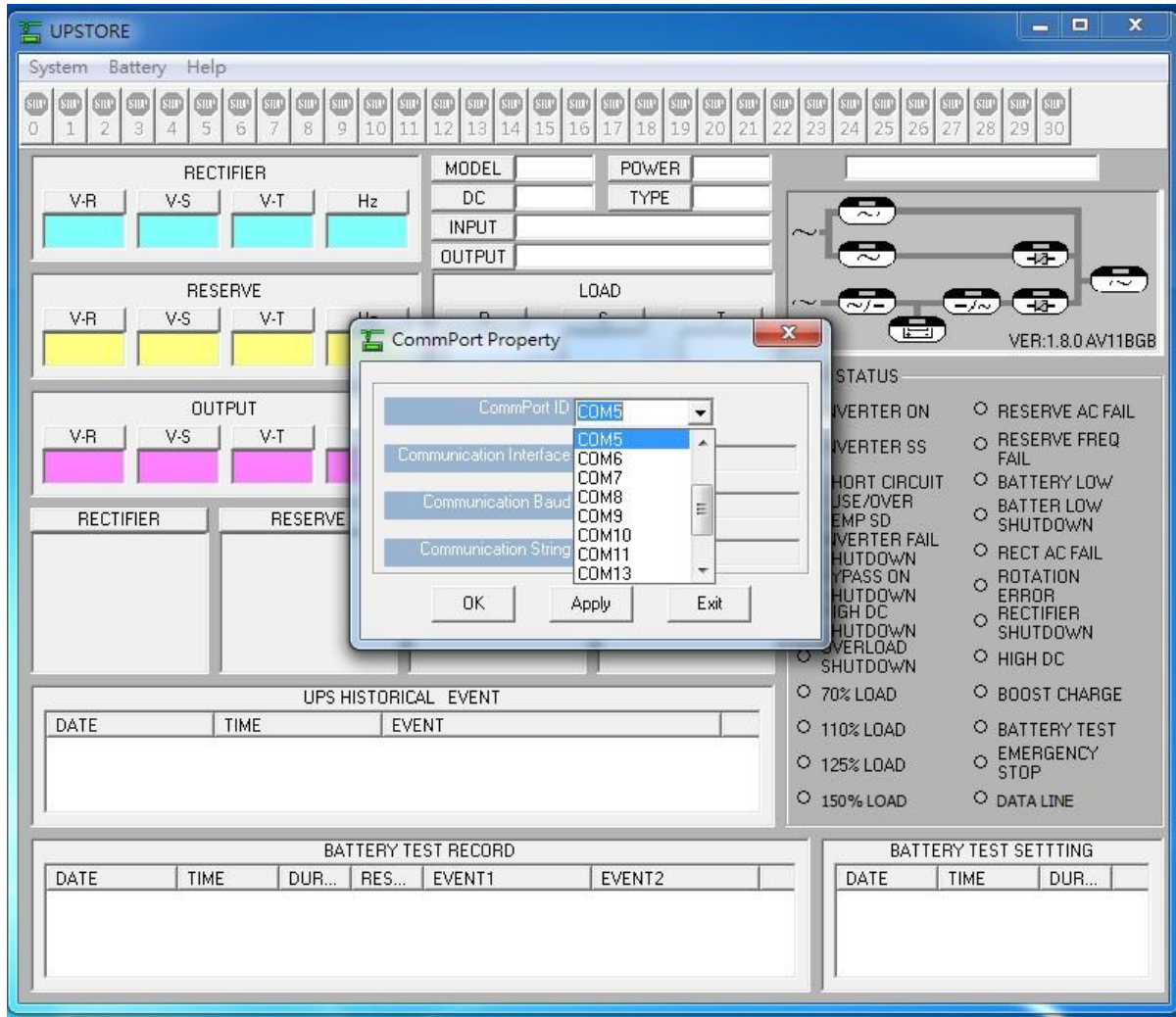

- Save to Excel File menu is not enable before all EE data has been downloaded to the computer.

B.17.1 Setting the battery test schedule

The screenshot shows the UPSTORE software interface with the 'Battery Settings' dialog box open. The dialog box is titled 'BATTERY TEST SCHEDULE' and contains the following fields:

- Month: 4
- Day: 20
- Test min.: 90
- Hour: 14
- Min: 7
- SAVE TO UPS button

The background interface displays various system parameters and status indicators:

- System Menu:** Settings, Refresh Settings and Records, Save Settings and Records to Excel File.
- System Info:** POWER 100KVA, TYPE UPS, INPUT 277/480V 3P4W 60Hz, OUTPUT 277/480V 3P4W 60Hz.
- UPS STATUS:** A list of status indicators including INVERTER ON, INVERTER SS, SHORT CIRCUIT FUSE/OVER TEMP SD, INVERTER FAIL SHUTDOWN, BYPASS ON SHUTDOWN, HIGH DC SHUTDOWN, OVERLOAD SHUTDOWN, 70% LOAD, 110% LOAD, 125% LOAD, 150% LOAD, RESERVE AC FAIL, RESERVE FREQ FAIL, BATTERY LOW SHUTDOWN, RECT AC FAIL, ROTATION ERROR, RECTIFIER SHUTDOWN, HIGH DC, BOOST CHARGE, BATTERY TEST, EMERGENCY STOP, and DATA LINE.
- UPS HISTORICAL EVENT:**

DATE	TIME	EVENT
2012/4/20	09:43PM	Normal Recovered
2012/4/20	09:45PM	Normal Recovered
2012/4/20	09:45PM	Rectifier AC Fail
- BATTERY TEST RECORD:**

DATE	TIME	DUR...	RES...	EVENT1	EVENT2
2012/4/20	04:10PM	1	FAIL	Battery Test Aborted	
2012/4/20	04:13PM	3	PASS		
2012/4/20	04:18PM	0	FAIL	Battery Test Aborted	
- BATTERY TEST SETTING:**

DATE	TIME	DUR...
JAN/2	01:04AM	2
FEB/2	01:04AM	2
MAR/2	01:04AM	2

1. Battery Testing

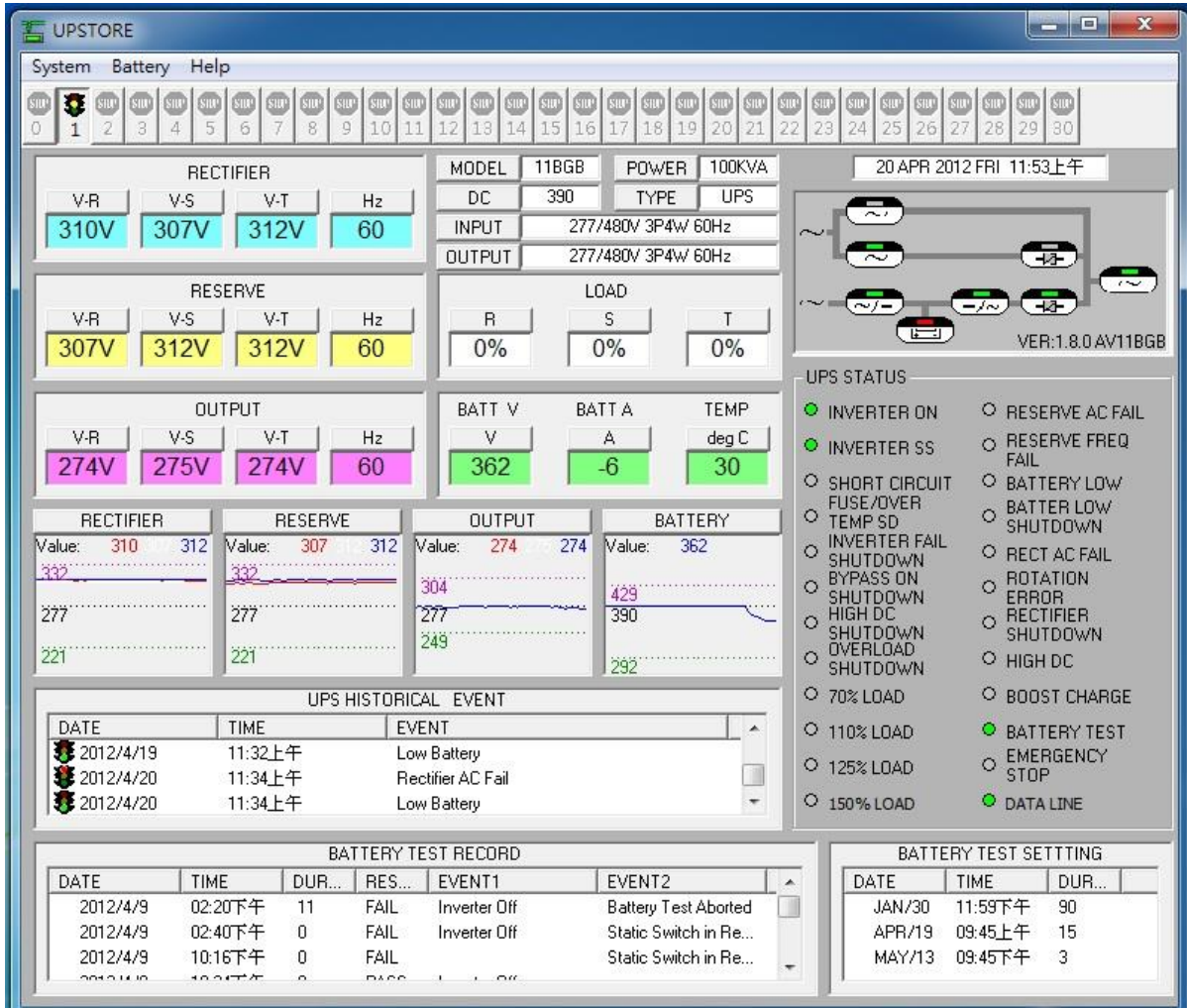

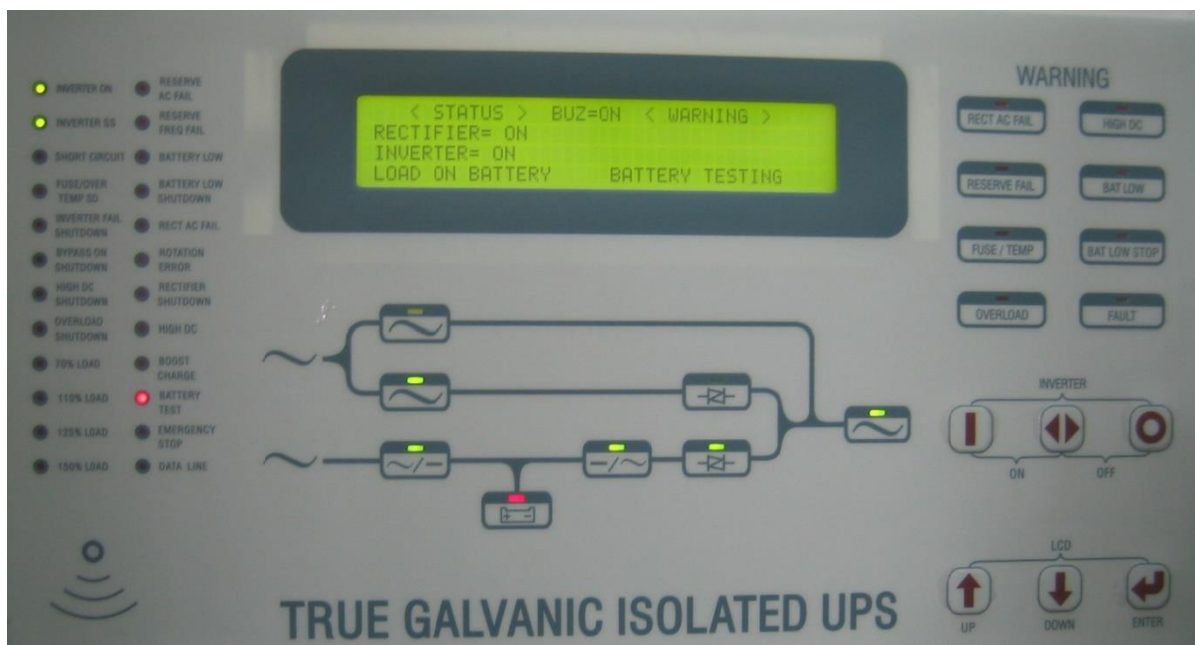

Note: Buzzer will BEEP



Note: If the UPS is in (ECO) Green mode, it will automatically come back to normal mode to do the battery test. After the test is finished it will automatically go back to the (ECO) Green mode.

2. To abort the battery test during the test: Parameter set. Password=1234



- Inverter manually turned OFF during battery test. Battery test manually aborted and Low Battery Shutdown will be recorded in EE

DATE	TIME	DUR...	RES...	EVENT1	EVENT2
2012/4/20	01:55PM	0	FAIL	Inverter Off	Static Switch in Re...
2012/4/20	01:57PM	0	FAIL	Battery Test Aborted	
2012/4/20	02:03PM	1	FAIL	Low Battery Shutdown	Inverter Off

- save excel file menu is enabled after all EE data has been downloaded to computer
- Save settings & records.

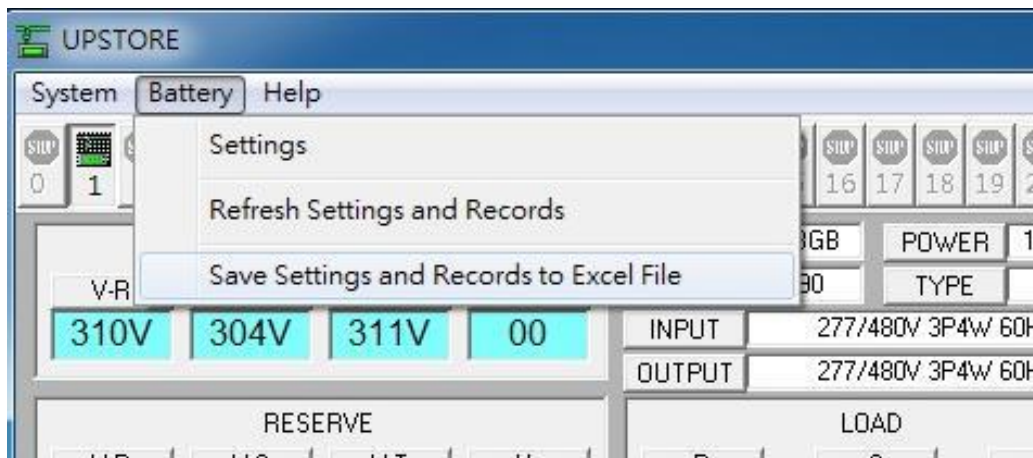

6. select path & key in filename:

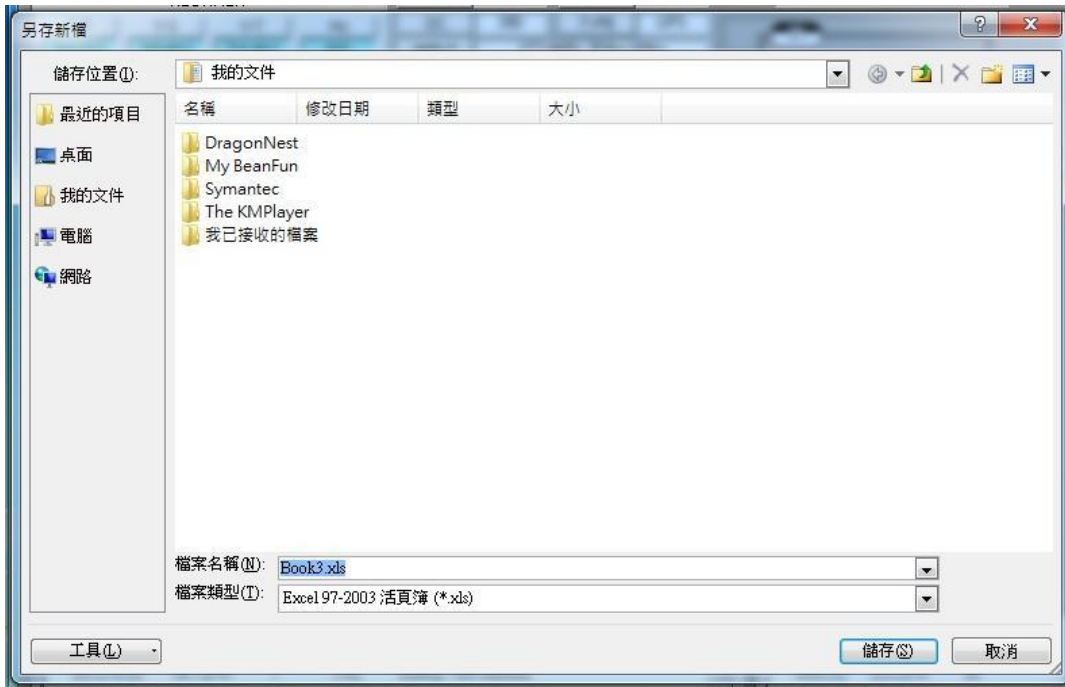

7. Open & check excel file:

1	SETTING					
2	DATE	TIME	DURATION			
3	20-Jan	03:23PM	90			
4	20-Apr	07:17PM	5			
5	13-May	09:45PM	3			
6						
7						
8						
9						
10	RECORD					
11	DATE	TIME	DURATION	RESULT	EVENT1	EVENT2
12	4/20/2012	04:10PM	1	FAIL	Battery Test Aborted	
13	4/20/2012	04:13PM	3	PASS		
14	4/20/2012	04:18PM	0	FAIL	Battery Test Aborted	
15	4/20/2012	04:24PM	0	FAIL	Inverter Off	Static Switch in Reserve
16	4/20/2012	04:28PM	0	FAIL	Inverter Off	Static Switch in Reserve
17	4/20/2012	04:35PM	5	PASS		
18	4/20/2012	04:51PM	0	FAIL	Low Battery Shutdown	Inverter Off
19	4/20/2012	05:20PM	3	FAIL	Battery Test Aborted	
20	4/20/2012	05:26PM	0	FAIL	Inverter Off	Static Switch in Reserve
21	4/20/2012	05:41PM	0	FAIL	Low Battery Shutdown	Inverter Off
22	4/20/2012	07:15PM	0	FAIL	Low Battery Shutdown	Inverter Off
23	4/20/2012	07:17PM	0	FAIL	Low Battery Shutdown	Inverter Off

B.18 Seismic Series

The Seismic Series are OSHPD / HCAI certified Three-Phase PWM Lighting Inverters that support power ratings from 24kw to 128kw. In addition to complying with UL1778, UL924, and CSA107.1 standard, these models meet the requirements for CBC 2016 and IBC 2015. They have been Shake table-tested in accordance with the ICC-ES AC156 procedure to SDS level 3.0g. The systems have received special seismic certification from the California Office of Statewide Health Planning and Development (OSHPD / HCAI), which are the most rigid seismic standards available.

Note: All Seismic Series models have an SV- prefix in their model number.

Table 7-1 UPS Cabinet Dimensions, Seismic Series, Shake Table tested

Capacity	UPS Cabinet Size (W x H x D in Inches)	Typical Battery Cabinet (Standard Battery)
24-50KW 30-60KVA	40.75 x 63 x 31.5 (Including brackets)	58.75 x 70 x 30.5 (Including brackets)

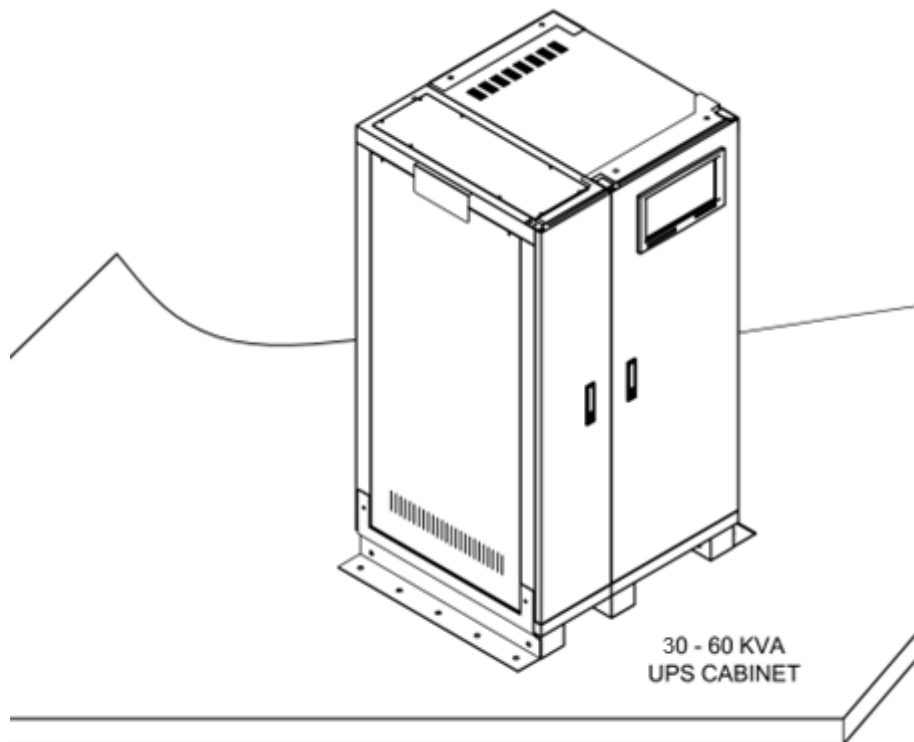

Figure 7.2. UPS Cabinet Dimensions, Seismic Series, Shake Table tested 10-60 KVA/8-48KW

Table 7-2 UPS Cabinet Dimensions, Seismic Series, Shake Table tested

Capacity	UPS Cabinet Size (W x H x D in Inches)	Typical Battery Cabinet (Standard Battery)
64-128KW 80-160KVA	62.5 x 63 x 31.5 (Including brackets)	58.75 x 70 x 30.5 (Including brackets)

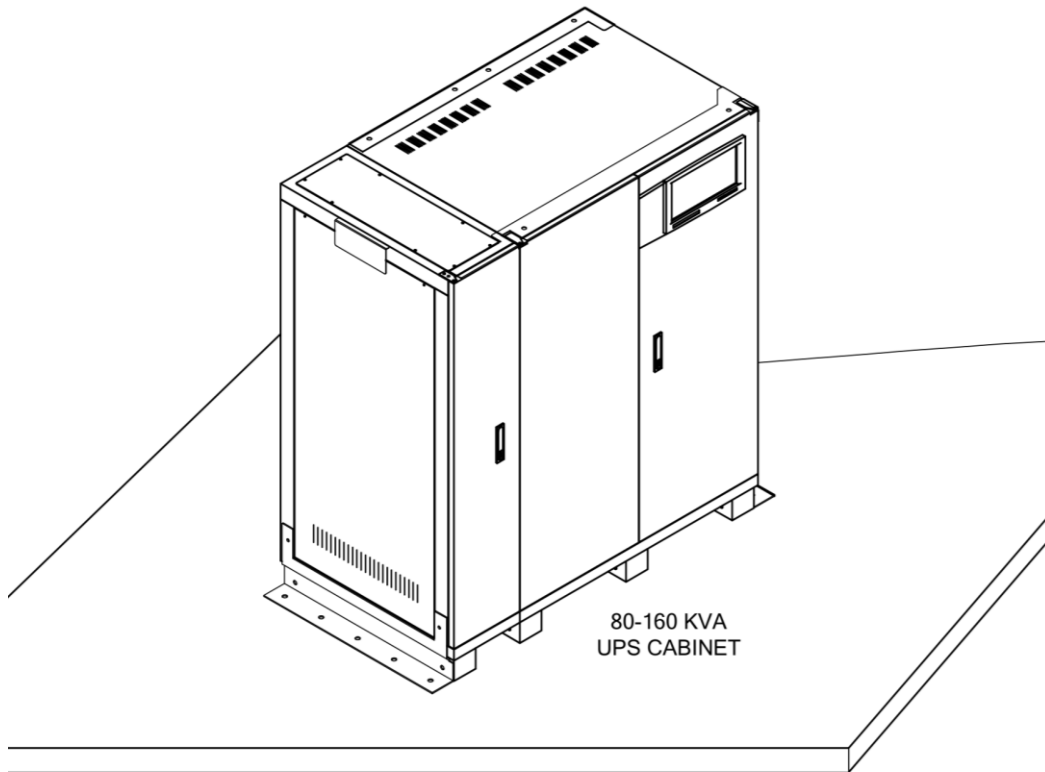

Figure 7.3. UPS Cabinet Dimensions, Seismic Series, Shake Table tested 80-160 KVA

APPENDIX C - SPECIFICATIONS

Typical Specifications

Input / Output Current								
kVA/kW	30/24	40/32	50/40	60/50	80/64	100/80	120/96	160/128
Input Voltage (vac)	208Y/120							
Output Voltage (vac)	208Y/120							
Input Max Current (Amps)	115	153	192	230	306	383	460	613
Output Max Current (Amps)	105	139	174	208	278	348	416	556
Input Voltage (vac)	480Y/277							
Output Voltage (vac)	480Y/277							
Input Max Current (Amps)	50	67	83	100	133	166	199	331
Output Voltage (vac)(Amps)	45	60	75	90	120	150	181	241
Input								
Voltage (vac)	Three Phase, 208Y/120, 480Y/277 VAC							
Voltage Regulation	±10%							
Frequency (Hz)	60 Hz ±5%							
Power Factor	≥ 0.97							
Crest factor	3:1 Typical							
Overcurrent protection	Electronic / Circuit Breaker							
Power walk-in time	20 sec from 0 to 100%							
Number of wires	4 Wires plus Ground							
Power connection	Hard Wired (Compression Terminal Block)							
Output								
Voltage (vac)	Three Phase, 208Y/120, 480Y/277 VAC							
Voltage regulation	At 100% Unbalanced Load – ±1%							
Frequency (Hz)	60 Hz ± 0.1 Hz							
Waveshape	Sinusoidal Wave							

Total Harmonics (THD)	Less than 2%
Crest factor	3:1
Power factor	0.8
Overload	Overload: 110-125%:15 minutes/125-150%: 5 minutes/Higher than 150%: 30 Seconds
Protection	Electronic / Circuit Breaker
Noise rejection	-120 dB Common Mode; -60 dB Normal Mode
Number of wires	4 Wires plus Ground
Power connection	Hard Wired (Terminal Block)

Battery

Battery run time	120 Minutes
Battery type	Sealed, Maintenance Free, AGM, VRLA
Nominal dc voltage (VDC)	348 VDC
Overcurrent protection	Circuit Breaker
Packaging	Batteries are housed in External Battery Cabinet(s)

Monitoring and Communications

LCD Screen	Real time status, Data or historical events, Parameters, Real time clock, inverter & alarm
LEDs	Up to date information (status), Audio alarm
Relay interface (Dry Contact)	Seven (7) N/C dry contacts (Optional)
Contact rating	Maximum rating is 16A/250VAC (16A/30VDC)
Interface connection	Terminal Block

Environmental

Surge with standability	ANSI C62.41-1980 categories A & B
Operating temperature	Meets NEMA requirements
Operating relative humidity	0 to 95% non-condensing
Altitude	Less than 1500 meter (5000 feet) Above Sea level
Cooling	Air cooled-forced air (fan)

Physical

Dimensions* (UPS) (W x H x D in Inches)	24 ~ 50 kW	64 – 128 kW
	34 x 75 x 31.5	55.5 x 75 x 31.5

Construction	Painted Steel Enclosure, Lockable front door, Full length hinged, for indoor installation,
Color	Black
Accessibility	Front all Servicing is through the front no side or rear access required
Cable entry	Top, Bottom for Raised Floor
Mounting	Four (4) mounting holes are provided for anchoring to floor, Hardware to be supplied by others

*Shaker table tested units are 63” in height

Due to continuous product improvement, this document is subject to change without prior notice.

Index

A

Audience5

B

Battery

connections.....50

maintaining.....76

recharging.....51

terminals.....78

Battery Monitoring.....98

C

Cabling47

Calling for service81

Climatization47

Customer service and support .81

D

Delivery46

Delivery space requirements ...35

E

Electrical connections

output load50

F

First-time power-up.....53

Floor load ratings.....45

FRU replacement79

H

Handling 46

I

Inspecting the shipment..... 46

Installation..... 34

climatization..... 47

M

Maintaining batteries..... 76

Maintenance..... 73

preventative..... 75

Maintenance agreements 82

Mounting 47

O

Offloading the system 46

Operating environment..... 45

Operation 52

Operator's log 75

Output load connections..... 50

P

Power connections..... 78

Preventative maintenance .75, 78

Product description..... 12

R

Recharging batteries 51

Requirements

delivery space..... 35

S

Safety.....7

Service..... 6, 81

Shipment

inspecting46

unpacking47

Site considerations43

Starting the unit

first time53

Start-up services.....81

Storing the system.....50

System

cabling and mounting47

climatization47

offloading46

storing50

T

Testing the UPS 76

Troubleshooting 83

Troubleshooting Guide and

System Alarms84

U

Unpacking47

UPS testing 76

W

Warranties82

Warranty registration and

warranty certificate request..6